



Worldwide
Contacts

www.tyco-fire.com

Model ESFR-17 16.8 K-factor Upright Sprinkler Early Suppression, Fast Response

IMPORTANT

Refer to Technical Data Sheet TFP300 for warnings pertaining to regulatory and health information.

Always refer to Technical Data Sheet TFP700 for the "INSTALLER WARNING" that provides cautions with respect to handling and installation of sprinkler systems and components. Improper handling and installation can permanently damage a sprinkler system or its components and cause the sprinkler to fail to operate in a fire situation or cause it to operate prematurely.

Scan the QR code or enter the URL in a web browser to access the most up-to-date electronic version of this document. Data rates may apply.



docs.jci.com/tycofire/tpf316

- Most encapsulated or non-encapsulated common materials including cartoned, unexpanded plastics
- Cartoned, expanded plastics
- Some storage arrangements of rubber tires and roll paper

For more specific criteria, see Table A and the applicable design standard.

The Model ESFR-17 Upright Sprinklers provide the system designer with an upright option to the traditional pendent ESFR Sprinklers. With a K-factor of 16.8, Model ESFR-17 Sprinklers provide system designers with hydraulic and sprinkler placement options not presently available to traditional ESFR Sprinklers having a K-factor of 14.0. In particular, the Model ESFR-17 Upright Sprinklers are designed to operate at substantially lower-end head pressures compared to ESFR Sprinklers with 14.0 K-factor. This feature offers flexibility when sizing system piping and positioning the system piping with respect to the ceiling.

NOTICE

The Model ESFR-17 Upright Sprinklers described herein must be installed and maintained in compliance with this document, as well as with the applicable standards of the National Fire Protection Association (NFPA), in addition to the standards of any authorities having jurisdiction, such as FM Global. Failure to do so may impair the performance of these devices.

The owner is responsible for maintaining their fire protection system and devices in proper operating condition. Contact the installing contractor or product manufacturer with any questions.

In all cases, the appropriate NFPA or FM Global installation standard must be referenced to ensure applicability and to obtain complete installation guidelines. The general guidelines in this data sheet are not intended to provide complete installation criteria.



Sprinkler Identification Number (SIN)

See Table A

Technical Data

Approvals

FM Approved
EAC Approved

Finish

Natural Brass

Physical Characteristics

FrameBrass
DeflectorCopper
Compression ScrewStainless Steel
HookMONEL
StrutMONEL
Link AssemblySolder, Nickel
ButtonBrass
Sealing AssemblyBeryllium Nickel w/TEFLON
Ejection SpringINCONEL
Deflector NutBrass

Additional Technical Data

See Table A

General Description

The TYCO Model ESFR-17 Upright-Sprinklers are Early Suppression, Fast Response (ESFR) sprinklers with a nominal K-factor of 16.8. The sprinkler assembly is shown in Figure 1. They are suppression mode sprinklers that are especially advantageous as a means of eliminating in-rack sprinklers when protecting high-piled storage.

Model ESFR-17 Sprinklers are primarily used for ceiling-only sprinkler protection of, but not limited to, the following storage applications:

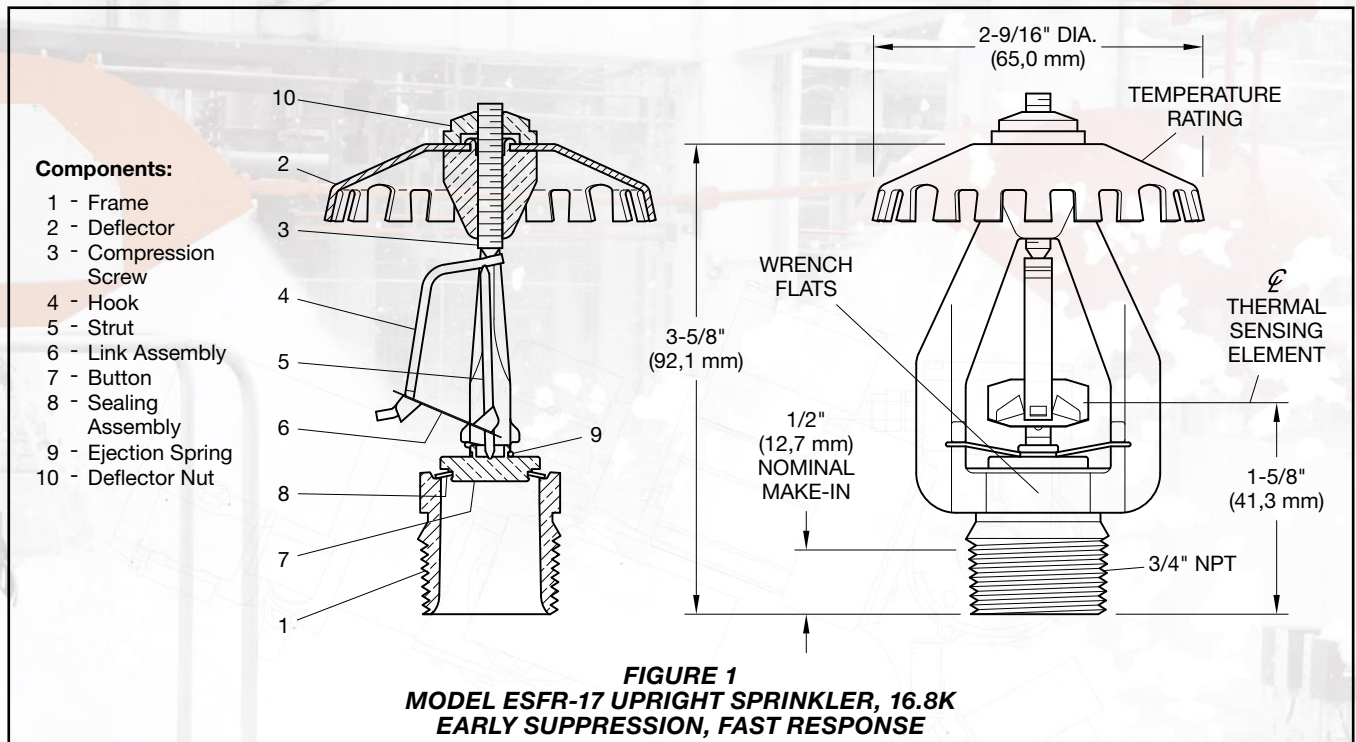

FIGURE 1
MODEL ESFR-17 UPRIGHT SPRINKLER, 16.8K
EARLY SUPPRESSION, FAST RESPONSE

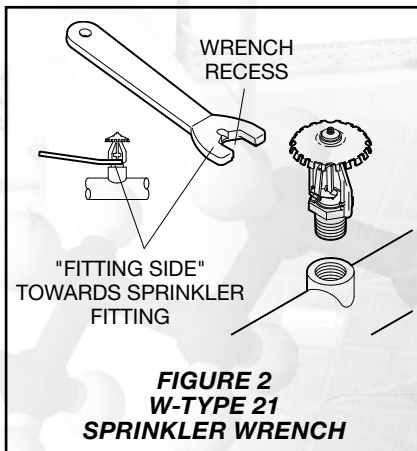

FIGURE 2
W-TYPE 21
SPRINKLER WRENCH

Item	Description
Sprinkler Identification Number (SIN)	TY7126
K-factor, gpm/psi ^{1/2} (Lpm/bar ^{1/2})	16.8 gpm/psi ^{1/2} (241,9 Lpm/bar ^{1/2})
Temperature Rating °F (°C)	165°F (74°C) 212°F (100°C)
Thread Size	3/4 in. NPT or ISO 7-R 3/4
Sprinkler Orientation	Upright
Maximum Working Pressure, psi (bar)	175 psi (12,1 bar)

TABLE A
MODEL ESFR-17 UPRIGHT SPRINKLER
TECHNICAL DATA

Operation

The fusible link assembly is comprised of two link halves that are joined together by a thin layer of solder. When the rated temperature is reached, the solder melts and the two link halves separate, activating the sprinkler and flowing water.

Design Criteria

The following general guidelines provided for the TYCO Model ESFR-17 Upright Sprinklers may be used for quick reference.

The National Fire Protection Association (NFPA) and FM Global (FM Approvals) provide installation standards that must be used to properly design an automatic sprinkler system utilizing Early Suppression, Fast Response (ESFR) Sprinklers. The guidelines provided by NFPA and FM Global may differ; consequently, the appropriate standard must be used for a given installation.

In all cases, the appropriate NFPA or FM Global installation standard must be referenced to ensure applicability and to obtain complete installation guidelines, since the following general guidelines are not intended to provide complete installation criteria. For more information, see Table B.

Roof Construction

Unobstructed or obstructed construction, such as smooth ceiling, bar joists, beam and girder.

Note: In buildings with obstructed construction, where the depths of the solid structural members, as in beams and stem, exceed 12 in. (302 mm), install ESFR Sprinklers in each channel formed by the structural members.

Ceiling Slope

Maximum 2 in. rise for 12 in. run (16.7%)

Maximum Coverage Area

100 ft² (9,3 m²)

Minimum Coverage Area

64 ft² (5,8 m²) per
 NFPA 13 and FM Global 2-0

Storage Type	NFPA	FM Global
Sprinkler Type	ESFR	Storage
Response Type	FR	QR
System Type	Wet	Wet
Temperature Rating °F (°C)	165°F (74°C) 212°F (100°C)	165°F (74°C) 212°F (100°C)
Open Frame (i.e., no solid shelves) Single, Double, Multiple-Row, or Portable Rack Storage of Class I-IV and Group A or B Plastics	Refer to NFPA 13	Refer to FM 2-0 and 8-9
Solid Pile or Palletized Storage of Class I-IV and Group A or B Plastics	Refer to NFPA 13	Refer to FM 2-0 and 8-9
Idle Pallet Storage	Refer to NFPA 13	Refer to FM 2-0, 8-9, and 8-24
Rubber Tire Storage	Refer to NFPA 13	Refer to FM 2-0 and 8-3
Roll Paper Storage (Refer to the Standard)	Refer to NFPA 13	Refer to FM 8-21
Flammable/Ignitable Liquid Storage (Refer to the Standard)	N/A	Refer to FM 7-29
Aerosol Storage (Refer to the Standard)	N/A	N/A
Automotive Components in Portable Racks (Control mode only; refer to the Standard)	N/A	N/A
N/A – Not Applicable		

TABLE B
MODEL ESFR-17 UPRIGHT SPRINKLER
COMMODITY SELECTION AND DESIGN CRITERIA OVERVIEW

Maximum Spacing

- 12 ft (3,7 m) for building heights up to 30 ft. (9,1 m)
- 10 ft (3,1 m) for building heights greater than 30 ft (9,1 m)

Minimum Spacing

8 ft (2,4 m)

Minimum Clearance to Commodity

36 in. (914 mm)

NFPA 13
Deflector-to-Ceiling Distance

3 in. to 12 in. (76,2 mm to 304 mm)

FM Global
Centerline of Thermal Sensing
Element-to-Ceiling Distance

Refer to FM Global 2-0 for Storage Sprinklers.

Obstructions below Upright ESFR Sprinklers, Including Branchlines

Per the requirements of FM, obstructions below upright ESFR Sprinklers can be ignored as follows:

- open-web bar joists or trusses having chords no more than 4 in. (102 mm) wide
- bridging or wind bracing no more than 4 in. (102 mm) wide
- individual pipes and conduit 4 in. (102 mm) diameter or less 3 in. [DN80] pipe size or less will not require sprigs)
- individual groups of smaller pipe or conduit having a total width of 4 in. or less

Installation

TYCO Model ESFR-17 Early Suppression, Fast Response 16.8K Upright Sprinklers must be installed in accordance with this section.

General Instructions

Avoid damage to the fusible Link Assembly during installation by using the Frame arms only to handle the sprinkler and by using the appropriate sprinkler wrench. Do not apply pressure to the fusible Link Assembly. Failure to do so can lead to an unstable link assembly and premature activation of the sprinkler. Damaged sprinklers must be replaced.

A leak-tight 3/4 in. NPT sprinkler joint should be obtained by applying a minimum-to-maximum torque of 10 to 20 lb-ft (13,4 to 26,8 N·m). Higher levels of torque can distort the sprinkler inlet with consequent leakage or impairment of the sprinkler.

Note: Install the Model ESFR-17 Upright Sprinkler in the Upright position as shown in Figure 2.

Step 1. With pipe thread sealant applied, hand-tighten the sprinkler into the sprinkler fitting. Do not apply pressure to the Link Assembly, and handle the Model ESFR-17 Sprinkler only by the Frame arms.

Step 2. Wrench-tighten the Model ESFR-17 Upright Sprinkler using only the W-Type 21 Sprinkler Wrench as shown in Figure 2, and by fully engaging (seating) the wrench on the sprinkler wrench flats as shown in Figure 1.

Step 3. After installation, inspect the Link Assembly of each Model ESFR-17 Sprinkler for damage. In particular, verify that the Link Assembly and Hook are positioned as shown in Figure 1, and that the Link Assembly is not bent, creased, or forced out of normal position in any way. Replace damaged sprinklers.

Care and Maintenance

TYCO Model ESFR-17 Early Suppression, Fast Response 16.8K Upright Sprinklers must be maintained and serviced in accordance with this section.

Before closing a fire protection system main control valve for maintenance work on the fire protection system that it controls, permission to shut down the affected fire protection system must be obtained from the proper authorities and notify all personnel who may be affected by this action.

Sprinklers which are found to be leaking or exhibiting visible signs of corrosion must be replaced.

Automatic sprinklers must never be painted, plated, coated, or otherwise altered after leaving the factory. Modified sprinklers must be replaced. Sprinklers that have been exposed to corrosive products of combustion, but have not operated, should be replaced if they cannot be completely cleaned by wiping the sprinkler with a cloth or by brushing it with a soft bristle brush.

Care must be exercised to avoid damage to the sprinklers before, during, and after installation. Sprinklers damaged by dropping, striking, wrench twist/slippage, or the like, must be replaced. Also, replace any sprinkler that has a cracked bulb or that has lost liquid from its bulb. For more information, see the Installation section.

The owner is responsible for the inspection, testing, and maintenance of their fire protection system and devices in compliance with this document, as well as with the applicable standards of the National Fire Protection Association, such as NFPA 25, in addition to the standards of any authorities having jurisdiction. Contact the installing contractor or product manufacturer with any questions.

Automatic sprinkler systems are recommended to be inspected, tested, and maintained by a qualified Inspection Service in accordance with local requirements and/or national codes.

Limited Warranty

For warranty terms and conditions, visit www.tyco-fire.com.

Ordering Procedure

Contact your local distributor for availability. When placing an order, indicate the full product name and part number (P/N).

Sprinkler Assemblies

Specify: Model ESFR-17 Early Suppression, Fast Response 16.8K Upright Sprinklers (TY7126), (specify temperature rating), with Natural Brass finish, P/N (specify):

165°F (74°C) 58-447-1-165
212°F (100°C) 58-447-1-214

Special Order

Sprinkler Assemblies with ISO 7-1 Thread Connection

Specify: Model ESFR-17 Early Suppression, Fast Response 16.8K Upright Sprinklers (TY7126) with ISO 7-1 thread connection, (specify temperature rating), with Natural Brass finish, P/N (specify):

165°F (74°C) 58-448-1-165
212°F (100°C) 58-448-1-214

Sprinkler Wrench

Specify: W-Type 21 Sprinkler Wrench, P/N 56-001-0-686

1467 Elmwood Avenue, Cranston, RI 02910 | Telephone +1-401-781-8220

© 2022 Johnson Controls. All rights reserved. All specifications and other information shown were current as of document revision date and are subject to change without notice.

NATIONAL FIRE PROTECTION ASSOCIATION and NFPA are registered trademarks of National Fire Protection Association; TEFLON is a trademark of The Chemours Company FC, LLC



 Worldwide
 Contacts

www.tyco-fire.com

TFP316 Change History Appendix

ISSUE DATE	NOTES
12-22	Page 1, updated QR code and URL; Page 2, Design Criteria Roof Construction sub-section, added note requiring sprinkler installed in each channel formed by structural members in areas of buildings with obstructed construction consisting of solid structural members exceeding 12 in. (302 mm) deep; Page 4, changed corporate address and telephone number to 1467 Elmwood Avenue, Cranston, RI 02910 Telephone +1-401-781-8220, formerly 1400 Pennbrook Parkway, Lansdale, PA 19446 Telephone +1-215-362-0700.
04-22	Page 1, Approvals sub-section, added EAC Approved.
11-21	Added QR code and URL to allow convenient access to electronic version from printed document.
03-21	Removed statement from General Description section indicating applications expanding beyond recognized installation standards and advising customers to contact Technical Services for fire test information potentially acceptable to authority having jurisdiction.
01-21	Removed CE certification.
12-20	Removed greater coverage area statements from Maximum Coverage Area and Maximum Spacing sections in Design Criteria; Removed references to other Tyco ESFR technical data sheets; Updated CE Certificate numbers.
03-20	Table B Commodity Selection and Design Criteria, changed NFPA Response Type to Fast Response (FR), formerly Quick Response (QR).
08-18	Updated Tyco® branding and document format; Added Johnson Controls copyright; Added disclaimer stating specifications and information subject to change without notice; Added reference to Regulatory and Health Warning Technical Data Sheet TFP2300.
05-18	Organized technical information into tables as required by UL; Changed CE Certificate of Conformity to 1725-CPR-F0012, formerly 1725-CPD-H0012.
12-15	Table A, Rubber Tire Storage, changed FM Global Data Sheet to 8-3, formerly shown as 8-9.
04-15	Changed Temperature Rating to 212°F (100°C), formerly shown as 214°F (101°C); Corrected deflector-to-ceiling distance 3 to 12 in. (76,2 to 304 mm), formerly 6 to 14 in. (152 to 356 mm).
10-14	Added reference to FM Loss Prevention Data Sheet 7-29, Installation Criteria for Systems Protecting Ignitable Liquid Storage in Portable Containers.
09-12	Added CE Certification.
03-11	Removed expired patent information.
02-11	Changed commodity selection and design criteria in accordance with industry standards.
10-09	Updated Design Criteria.
04-04	Added reference to Installer Warning data sheet TFP700; Updated installation criteria for rubber tire storage.
08-03	Added Design Criteria section; Updated patent information.
06-02	Added VdS Approved; Removed Design Criteria section, otherwise provided in NFPA 13 (2002) and FM Loss Prevention Data Sheet 8-9 (September, 2002).
05-02	New Technical Data Sheet TFP316 describes Model ESFR-17 Early Suppression, Fast Response, Upright Sprinkler.

1467 Elmwood Avenue, Cranston, RI 02910 | Telephone +1-401-781-8220

© 2022 Johnson Controls. All rights reserved. All specifications and other information shown were current as of document revision date and are subject to change without notice.

**Johnson
 Controls**

 NIP: 531-163-86-70
 REGON: 146196990