

tyco[®]

Worldwide
Contacts

www.tyco-fire.com

Series DS-1 – 5.6 K-factor, Dry-type Sprinklers Pendent, Upright, and Horizontal Sidewall Standard Response, Standard Coverage

IMPORTANT

Refer to Technical Data Sheet TFP2300 for warnings pertaining to regulatory and health information.

Always refer to Technical Data Sheet TFP700 for the “INSTALLER WARNING” that provides cautions with respect to handling and installation of sprinkler systems and components. Improper handling and installation can permanently damage a sprinkler system or its components and cause the sprinkler to fail to operate in a fire situation or cause it to operate prematurely.

Scan the QR code or enter the URL in a web browser to access the most up-to-date electronic version of this document. Data rates may apply.



docs.jci.com/tycofire/series-ds-1-5_6-k-dry-sprink-pen-up-side

General Description

TYCO Series DS-1 5.6K Pendent, Upright, and Horizontal Sidewall, Standard Response (5 mm bulb), Standard Coverage Dry-type Sprinklers are decorative glass bulb automatic sprinklers typically used where:

- pendent sprinklers are required on dry pipe systems that are exposed to freezing temperatures; for example, sprinkler drops from unheated portions of buildings

- sprinklers and/or a portion of the connecting piping may be exposed to freezing temperatures (for example, sprinkler drops from wet systems into freezers, or horizontal piping extensions through a wall to protect unheated areas of a building such as loading docks, overhangs, and building exteriors)
- sprinklers are used on systems that are seasonably drained to avoid freezing (for example, vacation resort areas)

NOTICE

Series DS-1 Dry-type Sprinklers described herein must be installed and maintained in compliance with this document, as well as with the applicable standards of the NATIONAL FIRE PROTECTION ASSOCIATION (NFPA), in addition to the standards of any other authorities having jurisdiction. Failure to do so may impair the performance of these devices.

The owner is responsible for maintaining their fire protection system and devices in proper operating condition. Contact the installing contractor or product manufacturer with any questions.

Series DS-1 Dry-type Sprinklers must only be installed in fittings that meet the requirements of the Design Criteria section.

Sprinkler Identification Numbers (SINs)

TY3255 – Pendent
TY3155 – Upright
TY3355 – Horizontal Sidewall

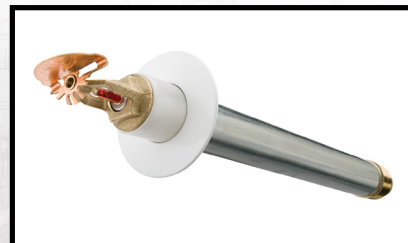
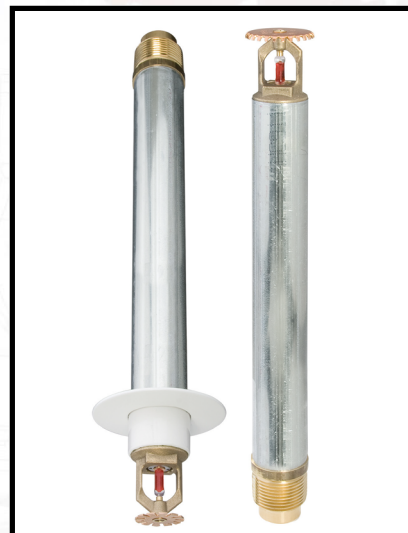

Technical Data

Approvals

UL and C-UL Listed
FM Approved
NYC Approved under MEA 352-01-E)
LPCB Approved, Reference No. 094a/11
CE Certified, Certificate of Conformity
No. 2831-CPR-S2015
EAC Approved

See Tables A and B for Approvals details.

Maximum Working Pressure

175 psi (12,1 bar)

Inlet Thread Connections

1 in. NPT
ISO 7-R 1

Discharge Coefficient

K=5.6 gpm/psi^{1/2} (80,6 lpm/bar^{1/2})

Temperature Ratings

See Tables A and B.

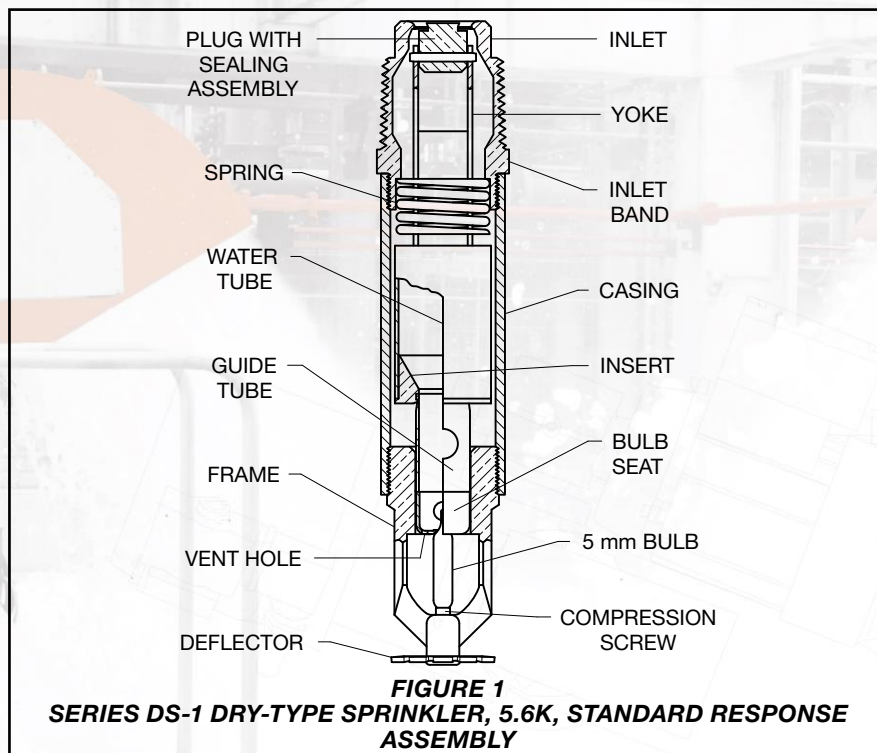
Finishes

 Sprinkler: See Table D.
 Escutcheon: See Table D.

Physical Characteristics

Inlet	Copper
Plug	Copper
Yoke	Stainless Steel
Casing	Galvanized Carbon Steel
Insert	Bronze
Bulb Seat	Stainless Steel
Bulb (5 mm dia.)	Glass
Compression Screw	Bronze
Deflector	Bronze
Frame	Bronze
Guide Tube	Stainless Steel
Water Tube	Stainless Steel
Spring	Stainless Steel
Sealing Assembly	Beryllium Nickel w/TEFLON
Escutcheon	Carbon Steel or Stainless Steel

Operation

When TYCO Series DS-1 5.6K Pendent, Upright, and Horizontal Sidewall, Standard Response, Standard Coverage Dry-type Sprinklers are in service, water is prevented from entering the assembly by the Plug with Sealing Assembly (see Figure 1) in the Inlet of the sprinkler.

The glass bulb contains a fluid that expands when exposed to heat. When the rated temperature is reached, the fluid expands sufficiently to shatter the glass bulb, and the Bulb Seat is released.

The compressed Spring is then able to expand and push the Water Tube as well as the Guide Tube outward. This action simultaneously pulls inward on the Yoke, withdrawing the Plug with Sealing Assembly from the Inlet, allow-

ing the sprinkler to activate and flow water.

Design Criteria

TYCO Series DS-1 5.6K Pendent, Upright, and Horizontal Sidewall, Standard Response, Standard Coverage Dry-type Sprinklers are intended for use in fire sprinkler systems designed in accordance with the standard installation rules recognized by the applicable listing or approval agency (for example, UL Listing is based on NFPA 13 requirements). For more information on LPCB Approval, contact Johnson Controls at the following office:

Kopersteden 1
 7547 TJ Enschede
 The Netherlands
 Tel: +31-(0)53-428-4444
 Fax: +31-(0)53-428-3377

Sprinkler Fittings

Install 1 in. NPT Series DS-1 Dry-type Sprinklers in the 1 in. NPT outlet or run of the following fittings:

- malleable or ductile iron threaded tee fittings that meet the dimensional requirements of ANSI B16.3 (Class 150)
- cast iron threaded tee fittings that meet the dimensional requirements of ANSI B16.4 (Class 125)

Do not install Series DS-1 Dry-type Sprinklers into elbow fittings. The Inlet

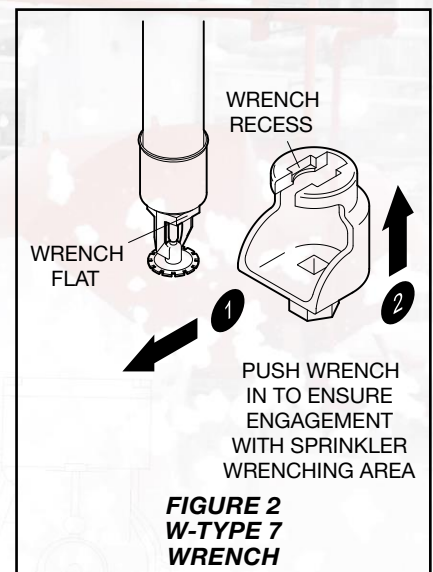

of the sprinkler can contact the interior of the elbow.

The unused outlet of the threaded tee is plugged as shown in Figure 12.

You can also install Series DS-1 Dry-type Sprinklers in the 1 in. NPT outlet of a GRINNELL Figure 730 Mechanical Tee and GRINNELL G-FIRE Figure 522; however, the use of the Figure 730 Tee and Figure 522 for this arrangement is limited to wet pipe systems.

The configuration shown in Figure 13 is only applicable for wet pipe systems where the sprinkler fitting and water-filled pipe above the sprinkler fitting are not subject to freezing and where the length of the dry-type sprinkler has the minimum exposure length depicted in Figure 11. See the Exposure Length section.

For wet pipe system installations of 1 in. NPT Series DS-1 Dry-Type Sprinklers connected to CPVC piping, use only the following TYCO CPVC fittings:

- 1 in. x 1 in. NPT Female Adapter (P/N 80145)
- 1 in. x 1 in. x 1 in. NPT Sprinkler Head Adapter Tee (P/N 80249)

For dry pipe system installations, use only the side outlet of maximum 2 1/2 in. reducing tee when locating Series DS-1 Dry-type Sprinklers directly below the branchline; otherwise, use the configuration shown in Figure 12 to assure complete water drainage from above Series DS-1 Dry-type Sprinklers and the branchline. Failure to do so may result in pipe freezing and water damage.

NOTICE

Do not install Series DS-1 Dry-type Sprinklers into any other type fitting.

SPRINKLER TYPE	ESCUTCHEON TYPE	TEMPERATURE RATING	BULB COLOR CODE	SPRINKLER FINISH						
				NATURAL BRASS	CHROME PLATED	POLYESTER*				
PENDENT (TY3255)	STANDARD	135°F (57°C)	Orange	1, 2, 3, 4, 5, 6		1, 2, 4, 5, 6				
		155°F (68°C)	Red							
		175°F (79°C)	Yellow							
		200°F (93°C)	Green							
		286°F (141°C)	Blue							
		360°F (182°C)	Mauve							
	RECESSED	135°F (57°C)	Orange	1, 2, 3, 5, 6		1, 2, 5, 6				
		155°F (68°C)	Red							
		175°F (79°C)	Yellow							
		200°F (93°C)	Green							
		286°F (141°C)	Blue							
		360°F (182°C)	Mauve							
	DEEP	135°F (57°C)	Orange	1, 2, 3, 4, 5, 6		1, 2, 4, 5, 6				
		155°F (68°C)	Red							
		175°F (79°C)	Yellow							
		200°F (93°C)	Green							
		286°F (141°C)	Blue							
		360°F (182°C)	Mauve							
		WITHOUT	135°F (57°C)				Orange	1, 2, 3, 6		1, 2, 6
			155°F (68°C)				Red			
			175°F (79°C)				Yellow			
200°F (93°C)			Green							
286°F (141°C)	Blue									
UPRIGHT (TY3155)	WITHOUT	135°F (57°C)	Orange	1, 2, 3, 4, 5, 6		1, 2, 4, 5, 6				
		155°F (68°C)	Red							
		175°F (79°C)	Yellow							
		200°F (93°C)	Green							
		286°F (141°C)	Blue							
		360°F (182°C)	Mauve							

Notes:

- Listed by Underwriters Laboratories, Inc. (UL), maximum order length of 48 in.
- Listed by Underwriters Laboratories for use in Canada (C-UL), maximum order length of 48 in.
- Approved by FM Global (FM Approvals), maximum order length of 48 in.
- Loss Prevention Certification Board (LPCB) and CE conformity apply to these temperature ratings only
- Approved by the City of New York under MEA 352-01-E
- EAC Approved
 - Frame and deflector only

TABLE A
SERIES DS-1 PENDENT & UPRIGHT DRY-TYPE SPRINKLERS, 5.6K, STANDARD RESPONSE
LABORATORY LISTINGS AND APPROVALS

Failure to use the appropriate fitting may result in one of the following:

- failure of the sprinkler to operate properly due to formation of ice over the Inlet Plug or binding of the Inlet Plug
- insufficient engagement of the Inlet pipe-threads with consequent leakage

Drainage

In accordance with the minimum requirements of the NATIONAL FIRE PROTECTION ASSOCIATION for dry

pipe sprinkler systems, branch, cross, and feed-main piping connected to Dry Sprinklers and subject to freezing temperatures must be pitched for proper drainage.

Exposure Length

When using Dry Sprinklers in wet pipe sprinkler systems to protect areas subject to freezing temperatures, use Table C to determine a sprinkler's appropriate exposed barrel length to prevent water from freezing in the connecting pipes due to conduction. The exposed barrel length measurement

must be taken from the face of the sprinkler fitting to the surface of the structure or insulation that is exposed to the heated area. See Figure 11 for an example.

For protected area temperatures between those given above, the minimum recommended length from the face of the fitting to the outside of the protected area may be determined by interpolating between the indicated values.

SPRINKLER TYPE	ESCUTCHEON TYPE	TEMPERATURE RATING	BULB COLOR CODE	SPRINKLER FINISH		
				NATURAL BRASS	CHROME PLATED	POLYESTER***
HSW* (TY3355)	STANDARD	135°F (57°C)	Orange	1**, 2**, 3**, 4, 5, 6		1**, 2**, 4, 5, 6
		155°F (68°C)	Red			
		175°F (79°C)	Yellow			
		200°F (93°C)	Green			
		286°F (141°C)	Blue			
		360°F (182°C)	Mauve			
	DEEP	135°F (57°C)	Orange			
		155°F (68°C)	Red			
		175°F (79°C)	Yellow			
		200°F (93°C)	Green			
		286°F (141°C)	Blue			
		360°F (182°C)	Mauve			
	WITHOUT	135°F (57°C)	Orange			
		155°F (68°C)	Red			
		175°F (79°C)	Yellow			
		200°F (93°C)	Green			
		286°F (141°C)	Blue			
		360°F (182°C)	Mauve			
Notes:				1**, 2**, 5, 6		1**, 2**, 6

1. Listed by Underwriters Laboratories, Inc. (UL), maximum order length of 48 in.
 2. Listed by Underwriters Laboratories for use in Canada (C-UL), maximum order length of 48 in.
 3. Approved by FM Global (FM Approvals), maximum order length of 48 in.
 4. Loss Prevention Certification Board (LPCB) and CE conformity apply to these temperature ratings only
 5. Approved by the City of New York under MEA 352-01-E
 6. EAC Approved
 * Horizontal sidewall with top of deflector-to-ceiling distance of 4 to 12 in. (100 to 300 mm)
 ** Light and ordinary hazard occupancies only
 *** Light hazard occupancies only
 **** Frame and deflector only

TABLE B
SERIES DS-1 HORIZONTAL SIDEWALL (HSW) DRY-TYPE SPRINKLER, 5.6K, STANDARD RESPONSE LABORATORY LISTINGS AND APPROVALS

Clearance Space

In accordance with NFPA 13, when connecting an area subject to freezing and an area containing a wet pipe sprinkler system, the clearance space around the sprinkler barrel of dry-type sprinklers must be sealed. Due to temperature differences between two areas, the potential for the formation of condensation in the sprinkler and subsequent ice build-up is increased. If this condensation is not controlled, ice build-up can occur that might damage the dry-type sprinkler and/or prevent proper operation in a fire situation.

Use of the Model DSB-2 Dry Sprinkler Boot, described in technical data sheet TFP591 and shown in Figures 14 and 15, can provide the recommended seal.

Installation

TYCO Series DS-1 5.6K Pendent, Upright, and Horizontal Sidewall, Standard Response, Standard Coverage Dry-type Sprinklers must be installed in accordance with this section.

General Instructions

Series DS-1 Dry-type Sprinklers must only be installed in fittings that meet the requirements of the Design Criteria section. See the Design Criteria section for other important requirements regarding piping design and sealing of the clearance space around the Sprinkler Casing.

Do not install any bulb-type sprinkler if the bulb is cracked or there is a loss of liquid from the bulb. With the sprinkler held horizontally, a small air bubble should be present. The diameter of the air bubble is approximately 1/16 in. (1,6 mm) for the 135°F (57°C) rating to 1/8 in. (3,2 mm) for the 360°F (182°C) rating.

Obtain a leak-tight 1 in. NPT sprinkler joint by applying a minimum-to-maximum torque of 20 to 30 lb-ft (26,8 to 40,2 N·m). Higher levels of torque may distort the sprinkler Inlet with consequent leakage or impairment of the sprinkler.

Do not attempt to compensate for insufficient adjustment in an Escutcheon Plate by under or over-tightening the Sprinkler. Re-adjust the position of

the sprinkler fitting to suit.

Notes:

- Install pendent sprinklers only in the pendent position; install upright sprinklers only in the upright position. The deflector of a pendent or upright sprinkler is to be parallel to the ceiling.
- Install horizontal sidewall sprinklers in the horizontal position with their centerline of waterway perpendicular to the back wall and parallel to the ceiling. Ensure the word "TOP" on the Deflector faces the ceiling.

Step 1. With a non-hardening pipe-thread sealant such as TEFLON applied to the inlet threads, hand-tighten the sprinkler into the sprinkler fitting.

Step 2. Wrench-tighten the sprinkler using either:

- a pipe wrench on the Inlet Band or the Casing, see Figure 1
- the W-Type 7 Sprinkler Wrench on the Wrench Flat, see Figure 2

Apply the wrench recess of the W-Type 7 Sprinkler Wrench to the wrench flat.

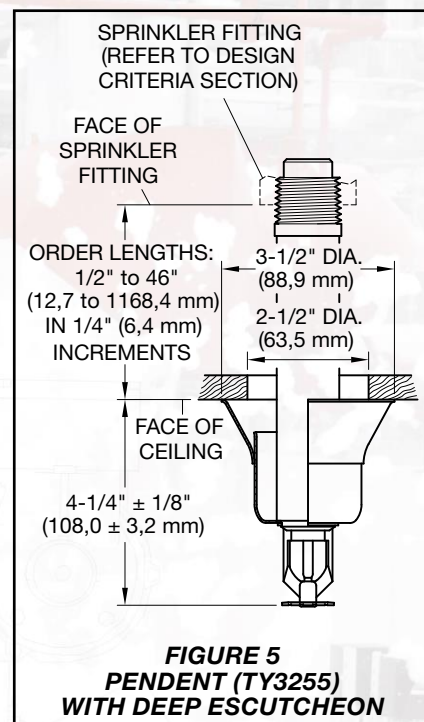
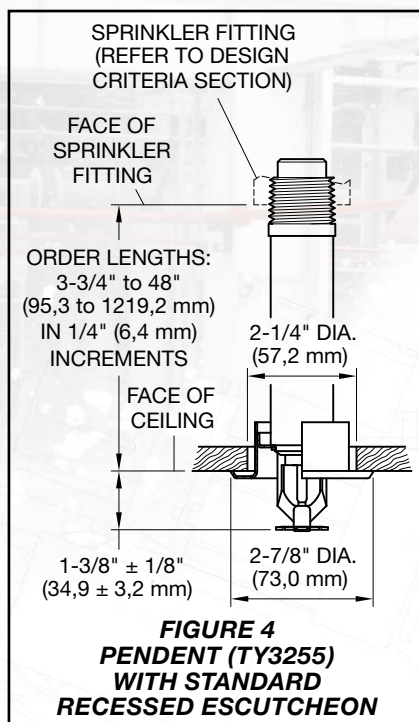
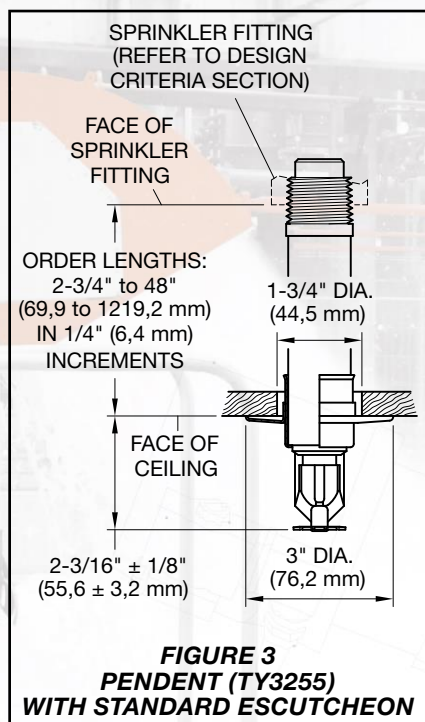

Note: If sprinkler removal becomes necessary, remove the sprinkler using the same wrenching method noted above. Sprinkler removal is easier when a non-hardening sealant was used and torque guidelines were followed. After removal, inspect the sprinkler for damage.

Step 3. After installing the ceiling or wall and applying a ceiling finish, slide on the outer piece of the escutcheon until it comes in contact with the ceiling/wall. Do not lift the ceiling panel out of its normal position.

When using the Deep Escutcheon, hold the outer piece in contact with the mounting surface (ceiling or wall). Then rotate the inner piece approximately 1/4 turn with respect to the outer piece, to hold the Deep Escutcheon firmly together.

Care and Maintenance

TYCO Series DS-1 5.6K Pendent, Upright, and Horizontal Sidewall, Standard Response, Standard Coverage Dry-type Sprinklers must be maintained and serviced in accordance with this section.

Before closing a fire protection system main control valve for maintenance work on the fire protection system that it controls, obtain permission to shut down the affected fire protection systems from the proper authorities

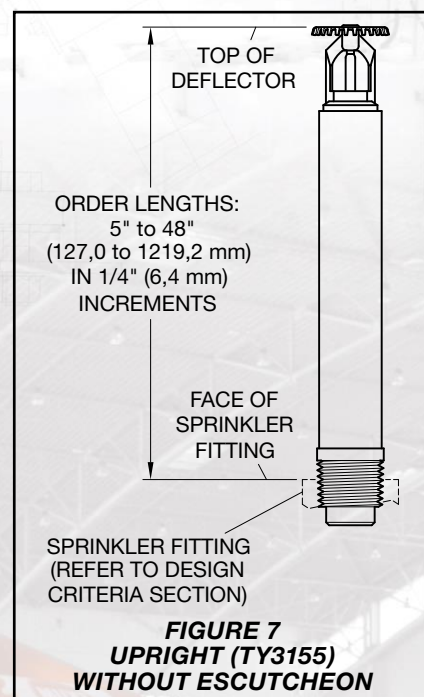
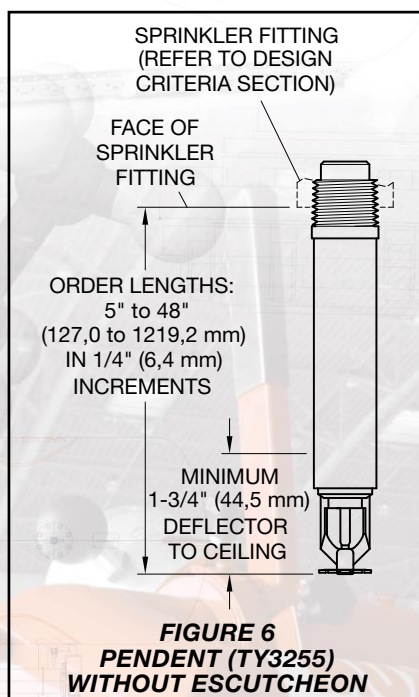

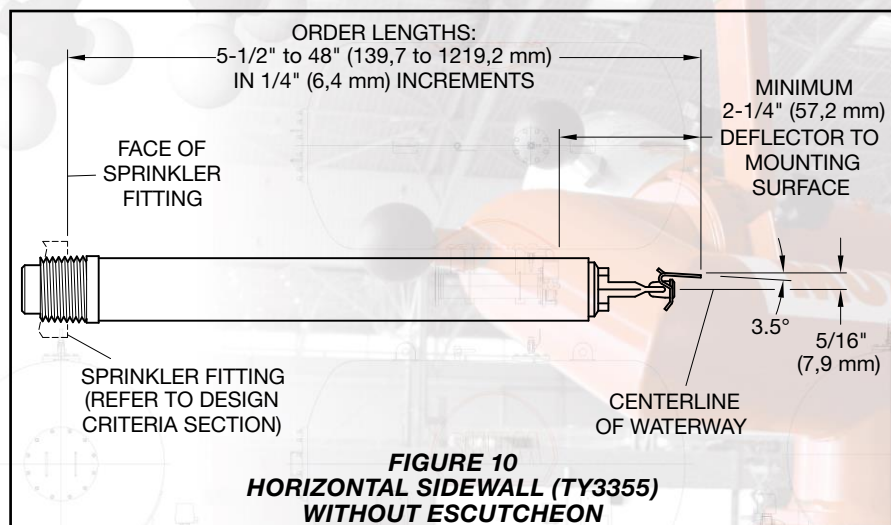
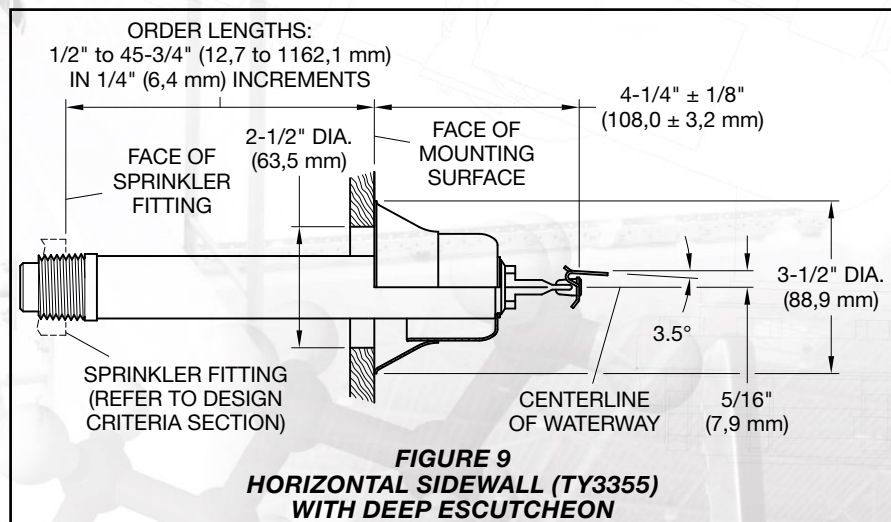
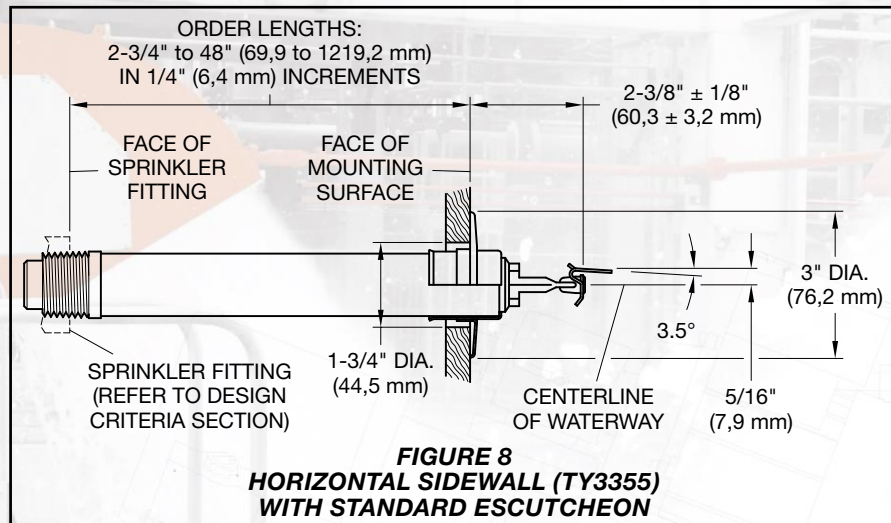

and notify all personnel who may be affected by this action.

Absence of the outer piece of an escutcheon, which is used to cover a clearance hole, may delay the time to sprinkler operation in a fire situation.

A Vent Hole is provided in the Bulb Seat (see Figure 1) to indicate if the Dry Sprinkler is remaining dry. Evidence of leakage from the Vent Hole indicates potential leakage past the Inlet seal and the need to remove the sprinkler to determine the cause of leakage; for example, an improper installation or an ice plug. Close the fire protection system control valve and drain the system before removing the sprinkler.

Sprinklers which are found to be leaking or exhibiting visible signs of corrosion must be replaced.

Automatic sprinklers must never be painted, plated, coated, or otherwise altered after leaving the factory. Modified sprinklers must be replaced. Sprinklers that have been exposed to corrosive products of combustion, but have not operated, should be replaced if they cannot be completely cleaned by wiping the sprinkler with a cloth or by brushing it with a soft bristle brush.

Care must be exercised to avoid damage to the sprinklers before, during, and after installation. Sprinklers damaged by dropping, striking, wrench twist/slippage, or the like, must be replaced. Also, replace any sprinkler that has a cracked bulb or that has lost liquid from its bulb. See the Installation section.

The owner is responsible for the inspection, testing, and maintenance of their fire protection system and devices in compliance with this document, as well as with the applicable standards of the NATIONAL FIRE PROTECTION ASSOCIATION, such as NFPA 25, in addition to the standards of any other authorities having jurisdiction. Contact the installing contractor or product manufacturer with any questions.

Automatic sprinkler systems are recommended to be inspected, tested, and maintained by a qualified Inspection Service in accordance with local requirements and/or national codes.

Ambient Temperature Exposed to Discharge End of Sprinkler	Temperatures for Heated Area ⁽¹⁾		
	40°F (4°C)	50°F (10°C)	60°F (16°C)
	Minimum Exposed Barrel Length ⁽²⁾ , in. (mm)		
40°F (4°C)	0	0	0
30°F (-1°C)	0	0	0
20°F (-7°C)	4 (100)	0	0
10°F (-12°C)	8 (200)	1 (25)	0
0°F (-18°C)	12 (305)	3 (75)	0
-10°F (-23°C)	14 (355)	4 (100)	1 (25)
-20°F (-29°C)	14 (355)	6 (150)	3 (75)
-30°F (-34°C)	16 (405)	8 (200)	4 (100)
-40°F (-40°C)	18 (455)	8 (200)	4 (100)
-50°F (-46°C)	20 (510)	10 (255)	6 (150)
-60°F (-51°C)	20 (510)	10 (255)	6 (150)

Notes:

- For protected area temperatures that occur between values listed above, use the next cooler temperature.
- These lengths are inclusive of wind velocities up to 30 mph (18,6 kph).

TABLE C
EXPOSED SPRINKLER BARRELS
IN WET PIPE SYSTEMS
MINIMUM RECOMMENDED
LENGTHS

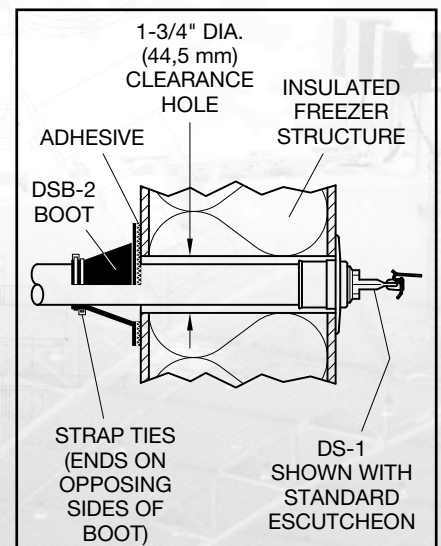
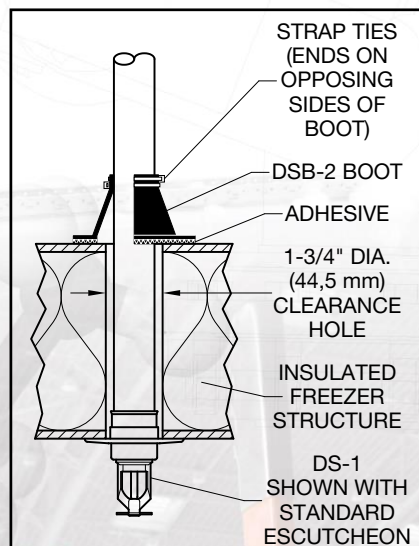
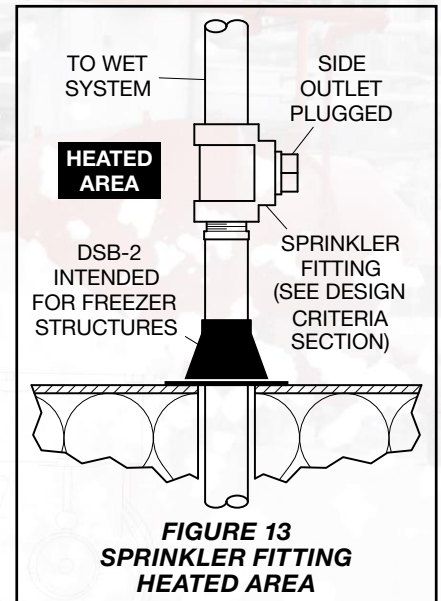
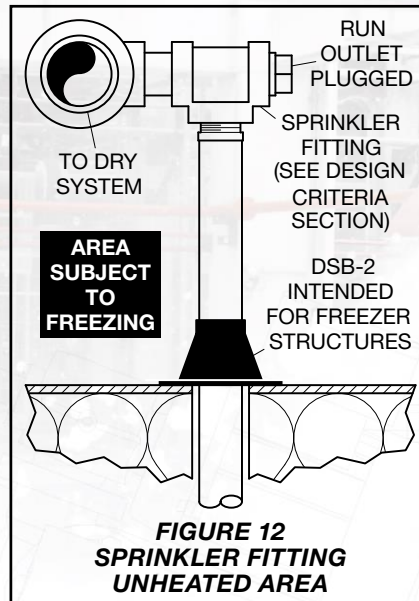
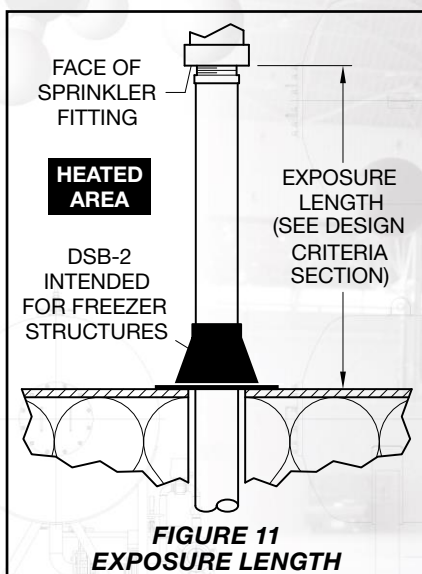

P/N* 60-XXX-X-XXX			SAMPLE ORDER LENGTH ³				
		SIN	SPRINKLER FINISH	ESCUTCHEON FINISH ¹			
96	Pendent with Standard Escutcheon (1 in. NPT)	TY3255 (Figure 3)	0	CHROME PLATED	SIGNAL WHITE (RAL9003) POLYESTER	055	5.50 in.
93	Pendent with Deep Escutcheon (1 in. NPT)	TY3255 (Figure 5)	1	NATURAL BRASS	SIGNAL WHITE (RAL9003) POLYESTER	082	8.25 in.
97	Pendent with Recessed Escutcheon (1 in. NPT)	TY3255 (Figure 4)	2	NATURAL BRASS	BRASS PLATED	180	18.00 in.
92	Pendent without Escutcheon (1 in. NPT)	TY3255 (Figure 6)	4	SIGNAL WHITE (RAL9003) POLYESTER	SIGNAL WHITE (RAL9003) POLYESTER	187	18.75 in.
94	Sidewall with Standard Escutcheon (1 in. NPT)	TY3355 (Figure 8)	8	CHROME PLATED	STAINLESS STEEL	372	37.25 in.
53	Sidewall with Deep Escutcheon (1 in. NPT)	TY3355 (Figure 9)	9	CHROME PLATED	CHROME PLATED	480	48.00 in.
54	Sidewall without Escutcheon (1 in. NPT)	TY3355 (Figure 10)					
98	Upright without Escutcheon (1 in. NPT)	TY3155 (Figure 7)					

		TEMPERATURE RATING ²			TEMPERATURE RATING ²
0	135°F (57°C)	3	200°F (93°C)		
1	155°F (68°C)	4	286°F (141°C)		
2	175°F (79°C)	5	360°F (182°C)		

Notes:

- Escutcheon Finish applies to sprinklers provided with escutcheons.
- 360°F (182°C) temperature rating applies to non-recessed sprinkler assemblies.
- Dry-type Sprinklers are furnished based upon "Order Length" as measured per Figures 3 through 10, as applicable, and for each individual sprinkler where it is to be installed. After the measurement is taken, round it to the nearest 1/4 in. increment.

* Use Prefix "I" for ISO 7-R 1 Connection (for example, I-60-961-1-180).

TABLE D
SERIES DS-1 DRY-TYPE SPRINKLERS, 5.6K, STANDARD RESPONSE
PART NUMBER SELECTION

Limited Warranty

For warranty terms and conditions, visit www.tyco-fire.com.

Ordering Procedure

Contact your local distributor for availability. When placing an order, indicate the full product name, including description and part number (P/N).

Dry-type Sprinklers

When ordering Series DS-1 5.6K Pendent, Upright, and Horizontal Sidewall, Standard Response, Standard Coverage Dry-type Sprinklers, specify the following information:

- SIN:
TY3255 – Pendent
TY3155 – Upright
TY3355 – Horizontal Sidewall
- Order Length:
Dry-type Sprinklers are furnished based upon Order Length as mea-

sured per Figures 3 through 10, as applicable. After the measurement is taken, round it to the nearest 1/4 in. increment.

- Inlet Connections:
1 in. NPT (Standard)
ISO 7-R 1
(For information on ISO Inlet Thread Connections, contact your Johnson Controls Sales Representative.)
- Temperature Rating
- Sprinkler Finish
- Escutcheon Type and Finish, as applicable
- P/N from Table D
Part numbers are for 1 in. NPT standard order sprinklers. Orders for all other sprinkler assemblies must be accompanied by a complete description.

Replacement Escutcheons

Order replacement escutcheons separately.

Note: Style 10 Recessed Escutcheons are shipped as assemblies comprised of closure ring and mounting plate. The

included mounting plate is not used for Dry Type Sprinkler applications, discard accordingly.

Specify: (specify type), (specify) finish, P/N (specify):

Recessed (Style 10)

Brass Plated 56-701-2-010
Signal White (RAL9003) 56-701-4-010
Chrome Plated 56-701-9-010

Standard (Push-On)

White Color 91-106-0-007
Brass Plated 91-106-2-007
Chrome Plated 91-106-9-007

Deep

Brass Plated 91-107-2-010
White 91-107-4-007
Chrome Plated 91-107-9-007

Sprinkler Wrench

Specify W-Type 7 Sprinkler Wrench, P/N 56-850-4-001

Sprinkler Boot

Specify Model DSB-2 Dry Sprinkler Boot, P/N 63-000-0-002

This part number includes one (1) Boot, two (2) Strap Ties, and 1/3 oz of Adhesive (a sufficient quantity for installing one boot).

1400 Pennbrook Parkway, Lansdale, PA 19446 | Telephone +1-215-362-0700

© 2022 Johnson Controls. All rights reserved. All specifications and other information shown were current as of document revision date and are subject to change without notice.

NATIONAL FIRE PROTECTION ASSOCIATION and NFPA are registered trademarks of National Fire Protection Association; TEFLON is a trademark of The Chemours Company FC, LLC

