

tyco[®]

Worldwide
Contacts | www.tyco-fire.com

Resilient-Seated Gate Valves Outside Screw and Yoke

IMPORTANT

Refer to Technical Data Sheet TFP2300 for warnings pertaining to regulatory and health information.

Scan the QR code or enter the URL in a web browser to access the most up-to-date electronic version of this document. Data rates may apply.



docs.jci.com/tycofire/TFP1541

General Description

TYCO Resilient-Seated Gate Valves are used in fire protection systems for on/off operation. The following end connection configurations are available:

- Flange x Flange
- Groove x Groove

All of the end connection configurations have tapping bosses.

The ductile Iron body weighs approximately 50% less than conventional cast iron valves, which allows easier handling on site and reduced shipping costs.

The fully encapsulated EPDM ductile iron wedge ensures bubble-tight sealing.

Valve components are either inherently corrosion-resistant or protected with fusion-bonded epoxy resin coating for a long, dependable service life.

This valve is one of the lightest, most durable gate valves on the market today. Its design features and material selection criteria fulfill the need for a dependable, long life and easy to operate gate valve.

NOTICE

Never remove any piping component nor correct or modify any piping deficiencies without first de-pressurizing and draining the system. Failure to do so may result in serious personal injury, property damage, and/or impaired device performance.

It is the designer's responsibility to select products suitable for the intended service and to ensure that pressure ratings and performance data are not exceeded. Material and gasket selection should be verified for compatibility with the specific application. Always read and understand the installation instructions.

TYCO Gate Valves described herein must be installed and maintained in compliance with this document, in addition to the standards of any other authorities having jurisdiction. Failure to do so may result in serious personal injury or impair the performance of these devices.

The owner is responsible for maintaining their mechanical system and devices in proper operating condition. The installing contractor or device manufacturer should be contacted with any questions.

Technical Data

Sizes

2 in. to 16 in. (DN50 to DN400)

Approvals

UL and ULC Listed
FM Approved
CE Certified
EAC Approved



Maximum Working Pressure

- 2 in. to 12 in. (DN50 to DN300): 300 psi (20,7 bar)
- 14 in. (DN350) and 16 in. (DN400): 250 psi (17,2 bar)

End Connections

Flange x Flange
Groove x Groove

Note: For size applicability, see Table A.

Flanges

ASME B16.1/ASME B16.42
EN 1092-2/ISO 7005-2
Drilled to ANSI 150 or PN10/PN16 or AS 2129 (Table E)

Materials of Construction

See Figure 1

Tapping Bosses

Two factory-plugged NPT threaded tapping bosses are located on the up- and downstream sides of the wedge for connection to valve trim. Tapping boss NPT Inch sizes:

2 in. to 6 in. (DN50 to DN150) 1/2
8 in. (DN200) 3/4
10 in. to 16 in. (DN250 to DN400) 1

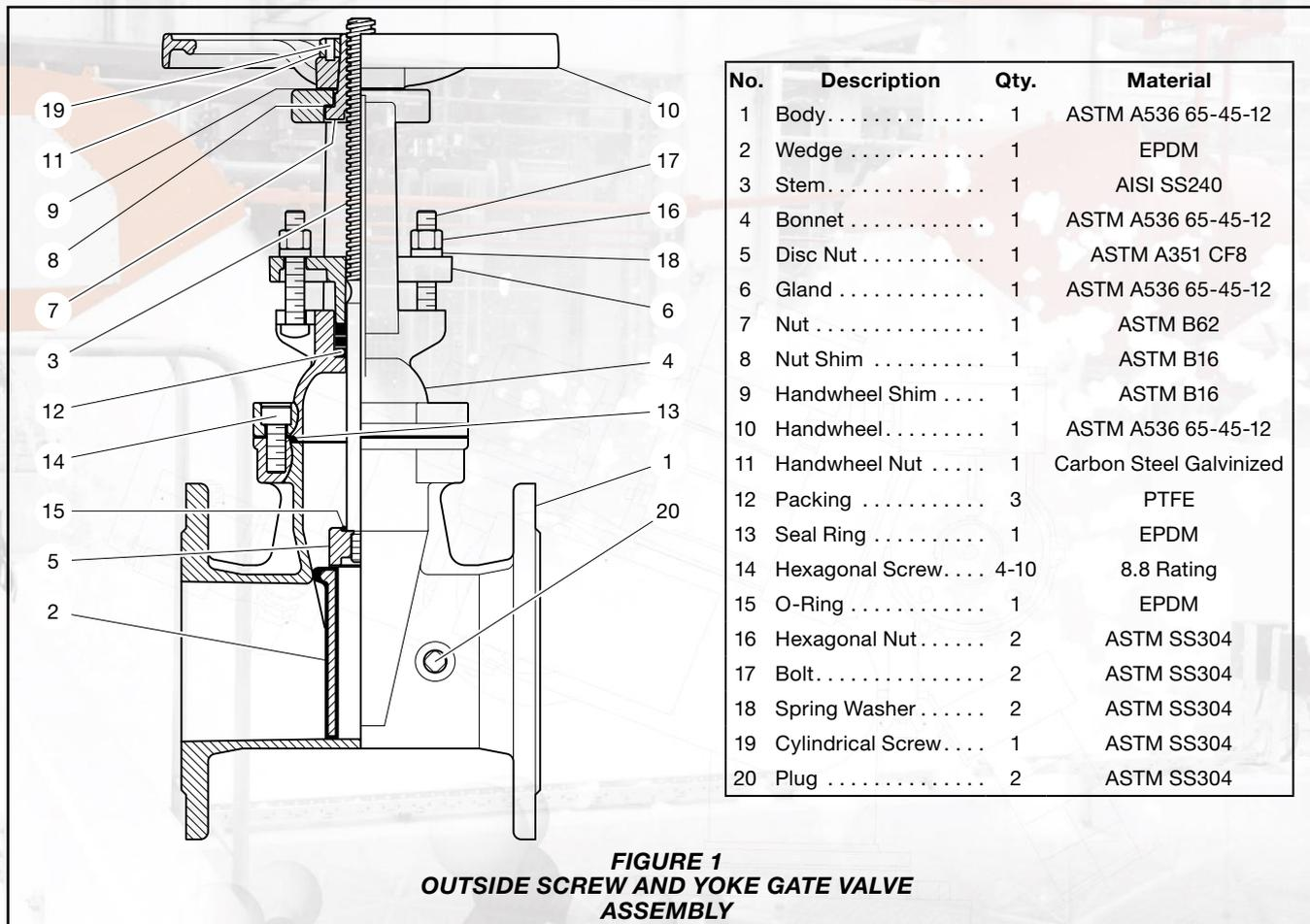

FIGURE 1
OUTSIDE SCREW AND YOKE GATE VALVE
ASSEMBLY

Installation

In piping systems, TYCO Resilient-Seated Gate Valves should be located where operation, inspection, and maintenance are readily accessible.

Care and Maintenance

The TYCO Resilient-Seated Gate Valves must be maintained and serviced in accordance with this section.

Before closing a fire protection system main control valve for maintenance work on the fire protection system that it controls, obtain permission to shut down the affected fire protection system from the proper authorities and notify all personnel who may be affected by this decision.

After placing a fire protection system in service, notify the proper authorities and advise those responsible for monitoring proprietary and/or central station alarms.

The owner is responsible for the inspection, testing, and maintenance of their fire protection system and devices

in compliance with this document, as well as with the applicable standards of the NFPA such as NFPA 25, in addition to the standards of any authority having jurisdiction. The installing contractor or product manufacturer should be contacted relative to any questions. Any impairments must be immediately corrected.

Automatic sprinkler systems are recommended to be inspected, tested, and maintained by a qualified Inspection Service in accordance with local requirements and/or national codes.

For valve components referenced in this section, see Figure 1

Debris lodged in the sealing area of the wedge (2) may cause the valve to close hard. Backing off the handwheel (10) and closing it again, several times if necessary, can correct this problem.

The valve should never be forced to seat by applying a wrench or extension to the handwheel (10), as it may distort the valve components or score the sealing surfaces. All replacement parts must be obtained from the manufacturer to assure proper operation of the valve.

At initial valve installation the Hexagonal nuts (16) should be left only finger tight to allow the packing (12) to remain in a relaxed state during normal valve operation.

After installation and before pressurizing the valve, inspect all pressure-bearing bolts and parts for adequate tightness to prevent leakage and ensure proper operation. Include the following parts, as shown in Figure 1:

- Bonnet (4)
- Gland (6)
- Plugs (20)
- Upstream or downstream connections (20) and end connections
- Handwheel (10)

For applications where the valve is subject to vibration, a non-hardening thread sealant may be applied to the hexagonal nuts (16) to prevent self-loosening and subsequent disengagement of the packing (12).

If leakage past the O-ring (15) occurs, evenly tighten the hexagonal nuts (16) until the leakage ceases.

Nominal Valve Size	Nominal Pipe Size	Nominal Dimensions in. (mm)			P Tapping Boss Size ANSI in. NPT	Nominal Handwheel Turns to Fully Operate (Open or Shut)	Approx. Weight F x F lb (kg)	Approx. Weight G x G lb (kg)
		ANSI in. DN	O.D. in. (mm)	L				
2 DN50	2.375 (60.3)	7.00 (178)	15.55 (395)	13.07 (332)	1/2	13	38.8 (17.64)	34.7 (15.8)
2 1/2 DN65	2.875 (73.0)	7.50 (190)	16.14 (410)	13.31 (338)		16	41.6 (18.91)	36.5 (16.6)
- DN65	3.000 (76.1)	7.50 (190)	16.14 (410)	13.31 (338)		16	41.6 (18.91)	36.5 (16.6)
3 DN80	3.500 (88.9)	8.00 (203)	18.9 (480)	14.96 (380)		20	48.7 (22.13)	48.0 (21.8)
4 DN100	4.500 (114.3)	9.00 (229)	22.56 (573)	17.72 (450)		20	59.8 (27.16)	52.8 (24.0)
- DN150	6.500 (165.1)	10.00 (254)	29.53 (750)	23.31 (592)		25	103.2 (46.9)	94.6 (43.0)
6 DN150	6.625 (168.3)	10.50 (267)	29.53 (750)	23.31 (592)		25	103.2 (46.9)	94.6 (43.0)
8 DN200	8.625 (219.1)	11.50 (292)	37.64 (956)	29.45 (748)	3/4	34	158.4 (72.0)	162.8 (74.0)
10 DN250	10.750 (273.1)	13.00 (330)	46.26 (1175)	34.96 (888)	1	42	244.2 (111.0)	233.2 (106.0)
12 DN300	12.750 (323.9)	14.00 (356)	51.89 (1318)	39.57 (1005)		50	367.4 (167.0)	352.0 (160.0)
14 DN350	14.014 (355.6)	15.00 (381)	62.09 (1577)	47.44 (1205)		20	631.4 (287.0)	-
16 DN400	16.000 (406.4)	15.98 (406)	70.87 (1800)	54.45 (1383)		20	827.2 (376)	-

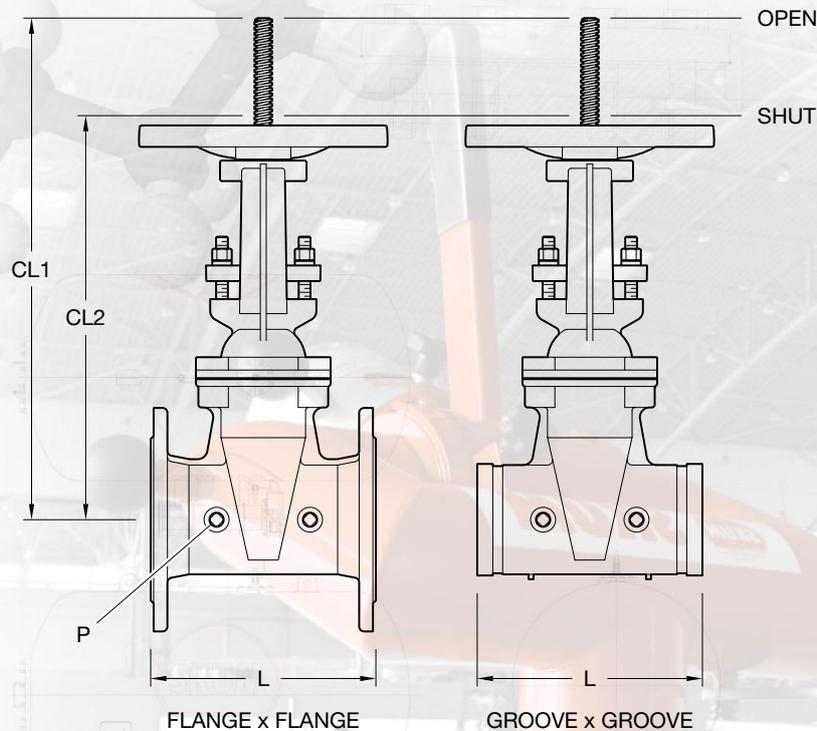
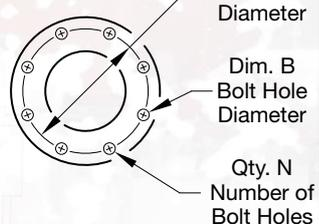

FIGURE 2
OUTSIDE SCREW AND YOKE GATE VALVE DN50 TO DN300
NOMINAL DIMENSIONS

Nominal Valve Size	Nominal Dimensions in In. (mm)									
	ANSI in. DN	ANSI Class 150			ISO 7005-2 PN16			AS 2129 (Table E)		
		Dim. A	Dim. B	Qty. N	Dim. A	Dim. B	Qty. N	Dim. A	Dim. B	Qty. N
2 DN50	4.75 (120.5)	0.75 (19)	4	4.92 (125.0)	0.75 (19)	4	4.48 (114.0)	0.71 (18.0)	4	
2 1/2 DN65	5.50 (139.5)	0.75 (19)	4	5.71 (145.0)	0.75 (19)	4	5.00 (127.0)	0.71 (18.0)	4	
3 DN80	6.00 (152.5)	0.75 (19)	4	6.30 (160.0)	0.75 (19)	8	5.74 (146.0)	0.71 (18.0)	4	
4 DN100	7.50 (190.5)	0.75 (19)	8	7.09 (180.0)	0.75 (19)	8	7.00 (178.0)	0.71 (18.0)	8	
6 DN150	9.50 (241.5)	0.88 (22)	8	9.45 (240.0)	0.88 (23)	8	9.25 (235.0)	0.87 (22.0)	8	
8 DN200	11.75 (298.5)	0.88 (22)	8	11.61 (295.0)	0.88 (23)	12	111.49 (292.0)	0.87 (22.0)	8	
10 DN250	14.25 (362.0)	1.00 (25)	12	13.98 (355.0)	1.13 (28)	12	14.02 (356.0)	0.87 (22.0)	12	
12 DN300	17.00 (432.0)	1.00 (25)	12	16.14 (410.0)	1.13 (28)	12	15.98 (406.0)	1.02 (26.0)	12	
14 DN350	18.75 (476.3)	1.13 (28.6)	12	18.5 (470.0)	1.102 (28)	16	19.49 (495.0)	1.22 (31.0)	16	
16 DN400	21.25 (539.8)	1.13 (28.6)	16	20.7 (525.0)	1.22 (31)	16	21.73 (552.0)	1.22 (31.0)	16	



Dim. A
Bolt Circle Diameter

Dim. B
Bolt Hole Diameter

Qty. N
Number of Bolt Holes

NOTES

- ANSI 150 and BS10 Table E flanges feature raised faces
- ANSI 125 and PN16 flanges feature flat faces
- (ANSI 125 listed only for differentiation from ANSI 150, Gate Valves featuring ANSI 125 flanges are not available)

**FIGURE 3
GATE VALVE FLANGE
NOMINAL DIMENSIONS**

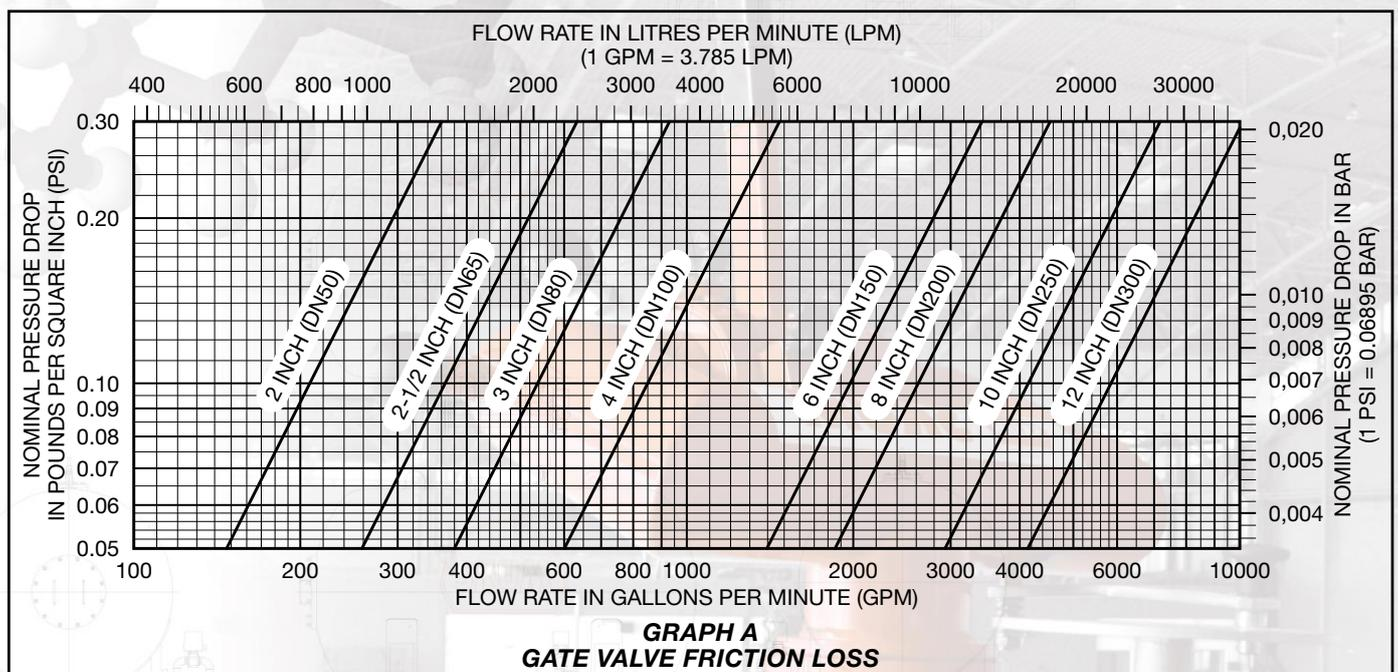

Nominal Valve Size	Nominal Pipe Size	Part Number			
		Flange x Flange ANSI Class 150	Flange x Flange ISO 7005-2 PN16	Flange x Flange AS 2129 (Table E)	Groove x Groove
2 DN50	2.375 (60.3)	TJRX0500003	TJRX0500001	TJRX0500005	TJRG0500604
2 1/2 DN65	2.875 (73.0)	TJRX0650003	TJRX0650001	TJRX0650005	TJRG0650734
– DN65	3.000 (76.1)	–	–	–	TJRG0650764
3 DN80	3.500 (88.9)	TJRX0800003	–	TJRX0800005	TJRG0800894
4 DN100	4.500 (114.3)	TJRX1000003	TJRX1000001	TJRX1000005	TJRG1001144
– DN150	6.500 (165.1)	–	–	–	TJRG1501654
6 DN150	6.625 (168.3)	TJRX1500003	TJRX1500001	TJRX1500005	TJRG1501684
8 DN200	8.625 (219.1)	TJRX2000003	TJRX2000001	TJRX2000005	TJRG2002194
10 DN250	10.750 (273.1)	TJRX2500003	TJRX2500001	TJRX2500005	TJRG2502734
12 DN300	12.750 (323.9)	TJRX3000003	TJRX3000001	TJRX3000005	TJRG3003244
14 DN350	14.0 (355.6)	TJRX3500003	TJRX3500001	TJRX3500005	–
16 DN400	16.0 (406.4)	TJRX4000003	TJRX4000001	TJRX4000005	–

TABLE A
OUTSIDE SCREW AND YOKE GATE VALVE
PART NUMBERS

Limited Warranty

For warranty terms and conditions, visit www.tyco-fire.com.

Ordering Procedure

Contact your local distributor for availability. When placing an order, indicate the full product name and Part Number (P/N). See Table A for a complete list of part numbers.

1467 Elmwood Avenue, Cranston, RI 02910 | Telephone +1-401-781-8220

© 2023 Johnson Controls. All rights reserved. All specifications and other information shown were current as of document revision date and are subject to change without notice.

NATIONAL FIRE PROTECTION ASSOCIATION and NFPA are registered trademarks of National Fire Protection Association

NIP: 531-163-86-70
REGON: 146196990

tyco[®]

Worldwide
Contacts | www.tyco-fire.com

TFP1541 **Change History Appendix**

ISSUE DATE	NOTES
06-23	Throughout document, removed all instances of Flange x Groove ANSI and ISO PN16 valves, no longer offered; Page 5, Table A, removed part number for 3 in. (DN80) Flange x Flange ISO PN16 valve, product no longer offered.
01-23	Page 1, General Description section, removed statement indicating epoxy resin coating provides enhanced UV protection in exposed installations; Page 1, Approvals sub-section, added CE Certified plus added CE mark.
09-22	Page 1, updated QR code and URL; Page 1, Approvals sub-section, added EAC Approved; Page 6, changed corporate address and telephone number to 1467 Elmwood Avenue, Cranston, RI 02910 Telephone +1-401-781-8220, formerly 1400 Pennbrook Parkway, Lansdale, PA 19446 Telephone +1-215-362-0700.
04-22	Page 1, added QR code and URL to allow convenient access to electronic version from printed document; Page 2, Care and Maintenance section, right column, added paragraph requiring inspection for adequate tightness of pressure-bearing bolts and parts before pressurizing valve.
04-21	Corrected centerline to top of stem dimensions CL1 (open condition) and CL2 (closed condition) for 14 in. and 16 in. (DN350 and DN400) sizes.
03-21	Clarified flat and raised face characteristics of flange options.
12-20	Removed valve model name from document title and General Description and Care and Maintenance sections.
06-19	Added Russian Fire Certificate.
12-18	New Technical Data Sheet TFP1541 describes Model TJR Resilient-Seated Gate Valves Outside Screw and Yoke.

1467 Elmwood Avenue, Cranston, RI 02910 | Telephone +1-401-781-8220

© 2023 Johnson Controls. All rights reserved. All specifications and other information shown were current as of document revision date and are subject to change without notice.

Johnson
Controls 

NIP: 531-163-86-70
REGON: 146196990

 **Foamax**[®]
Fire fighting systems & equipment

SABO
FOAM

SKUM

InfraTec

 **ANSUL**

 **WILLIAMS**

tyco