



 Worldwide
 Contacts | www.tyco-fire.com

Model AV-1-300 Alarm Valve With and Without Model RC-1 Retard Chamber European Conformity Valve Trim

IMPORTANT

Refer to Technical Data Sheet TFP2300 for warnings pertaining to regulatory and health information.

Scan the QR code or enter the URL in a web browser to access the most up-to-date electronic version of this document. Data rates may apply.



docs.jci.com/tycofire/TFP990

General Description

The TYCO Model AV-1-300 Alarm Valves DN65, DN100, DN150, and DN200 (European Conformity) are divided-seat ring, rubber-faced clapper, waterflow alarm valves that are intended for use in wet pipe (automatic sprinkler) fire protection systems. They are designed to automatically actuate electric and/or hydraulic alarms when there is a steady flow of water into the system that is equivalent to the discharge rate of one or more sprinklers.

An optional Model RC-1 Retard Chamber is required for installations subject to variable pressures. It is used to help prevent false alarms associated with pressure variations in public water supplies.

The Model AV-1-300 Alarm Check Valve Trim includes pressure gauges to monitor system pressure conditions, a by-pass check valve, a main drain valve, and an alarm test valve. The bypass check valve reduces the possibility of false alarms by permitting slow as well as small transient increases in water supply pressure through the system without opening the waterway clapper.

NOTICE

The TYCO Model AV-1-300 Alarm Check Valves and TYCO Model RC-1 Retard Chamber described herein must be installed and maintained in compliance with this document as well as the standards recognized by the Approval agency, in addition to any other authorities having jurisdiction. Failure to do so may impair the performance of these devices.

The owner is responsible for maintaining their fire protection system and devices in proper operating condition. The installing contractor or manufacturer should be contacted with any questions.



| Nominal Valve Sizes | Groove x Groove | Flange x Groove | Flange x Flange |
|---------------------|-----------------|-----------------|-----------------|
| DN65 76,1 mm | 10,0 Kg | 12,7 Kg | N/A |
| DN100 114,3 mm | 17,2 Kg | 21,3 Kg | 25,9 Kg |
| DN150 165,1 mm | 26,3 Kg | 31,8 Kg | 38,1 Kg |
| DN150 168,3 mm | 26,3 Kg | 31,8 Kg | 38,1 Kg |
| DN200 219,1 mm | 46,3 Kg | 54,4 Kg | 67,6 Kg |

**TABLE A
 AVAILABLE VALVE
 END CONNECTIONS
 AND WEIGHTS**

| VALVE PARTS | | | VALVE PARTS | | | REPLACEMENT PARTS | |
|-------------|-------------------|------------------|-------------|-------------------|-----------|-------------------|-------------------|
| NO. | DESCRIPTION | QTY. REF. | NO. | DESCRIPTION | QTY. REF. | NO. | DESCRIPTION P/N |
| 1 | Valve Body | 1 NR | 12 | Handhole Cover | | (a) | Repair Parts Kit, |
| 2 | Handhole Cover | 1 NR | | Hex Bolt, | | | Includes 3 & 6 |
| 3 | Handhole Cover | | | DN65 Valve, | | | DN65 Valve |
| | Gasket | 1 See (a) | | 1/2-13 UNC-2A | | | 92-200-1-216 |
| 4 | Seat Ring | 1 NR | | x 1-1/4" Long | 4 CH | | DN100 Valve |
| 5 | Clapper | 1 See (b) | | DN100 Valve, | | | 92-200-1-416 |
| 6 | Clapper Facing | 1 See (a) or (b) | | 1/2-13 UNC-2A | | | DN150 Valve |
| 7 | Clapper Washer | 1 See (b) | | x 1-3/4" Long | 4 CH | | 92-200-1-620 |
| 8 | Lock Nut, | | | DN150 Valve, | | | DN200 Valve |
| | DN65 Valve | 1 See (b) | | 1/2-13 UNC-2A | | | 92-200-1-816 |
| | Self-Locking Hex | | | x 1-3/4" Long | 6 CH | (b) | Clapper Assembly, |
| | Cap Screw, DN100, | | | DN200 Valve, | | | Includes 5-9, 11 |
| | 150 & 200 Valves | 1 See (b) | | 3/4-10 UNC-2A | | | DN65 Valve |
| 9 | Clapper Hinge Pin | 1 See (b) | | x 2" Long | 6 CH | | 92-200-1-218 |
| 10 | Clapper Hinge | | 13 | Clapper Hinge Pin | | | Includes 5-11 |
| | Pin Bushing, | | | Square Head Pipe | | | DN100 Valve |
| | DN65 Valve | 2 NR | | Plug, 3/8" NPT, | | | 92-200-1-423 |
| | DN100, 150 & 200 | | | DN100, 150 & 200 | | | DN150 Valve |
| | Valves | 4 NR | | Valves only | 1 CH | | 92-200-1-623 |
| 11 | Clapper Spring | 1 See (b) | | | | | DN200 Valve |
| | | | | | | | 92-200-1-823 |

NOTES:

1. F x F valve shown for reference; components for G x G and F x G valves are shared.
2. NR: Not Replaceable
3. CH: Common Hardware

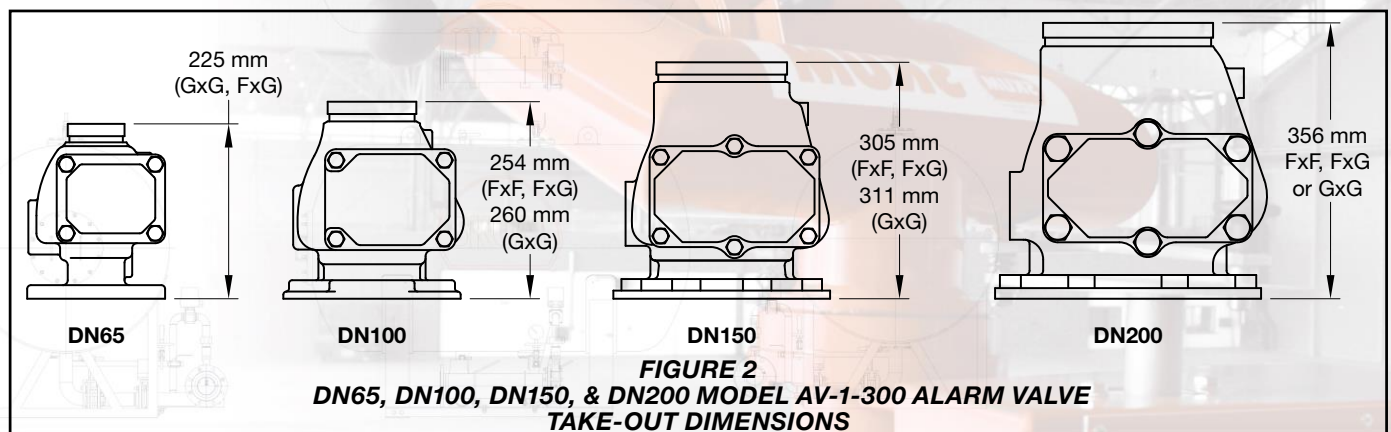
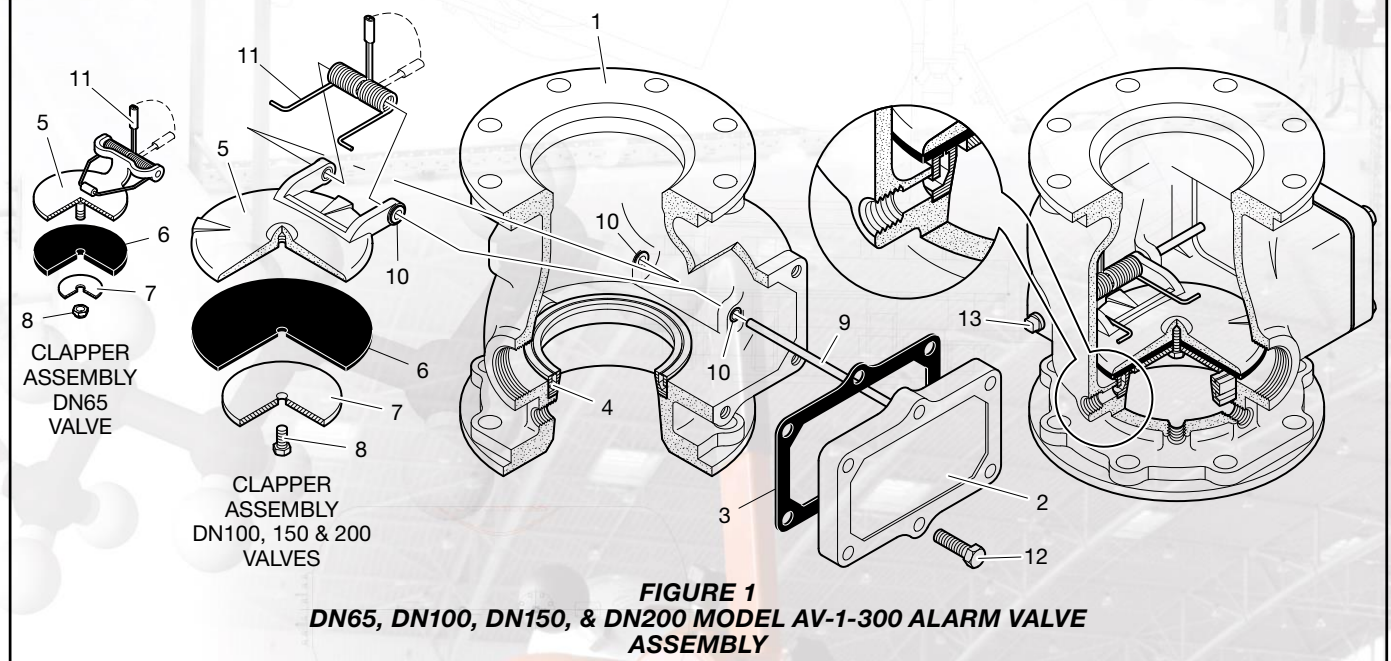

Technical Data

Sizes

DN65, DN100, DN150, and DN200

Approvals

The TYCO Model AV-1-300 Alarm Valves DN65, DN100, DN150, and DN200 (European Conformity) with or without the Model RC-1 Retard Chamber are FM, EAC, VdS, and LPCB Approved as with European Conformity Valve Trim. Refer to Figures 4A through 11B.

For more information on LPCB Approval, contact Johnson Controls at the following office:

Kopersteden 1
7547 TJ Enschede
The Netherlands

Tel: +31-(0)53-428-4444

Fax: +31-(0)53-428-3377

Alarm Valve

The DN65, DN100, DN150, and DN200, Model AV-1-300 Valves with European Conformity Valve Trim are for vertical installations (flow going up), and they are rated for use at a maximum service pressure of 16 bar. Nominal pressure loss versus flow is shown in Graph A, and the valve take-out dimensions are shown in Figure 2.

Flanged connections are drilled per ISO 2084 (PN10/16) or ANSI B16.1 (Class 125). Refer to Table B. Grooved connections, as applicable, are cut in accordance with standard groove specifications for steel pipe. They are suitable for use with grooved end pipe couplings listed or approved for fire protection system service.

Threaded port connections are per ISO 7/1 to readily accept the trim arrangements detailed in Figures 4A through 11B.

Components of the Alarm Valve are shown in Figure 1. The body and Hand-Hole Cover are ductile iron. The Seat Ring is bronze. The Clapper is ductile iron. All valve sizes utilize an EPDM Clapper Facing.

Retard Chamber

The Model RC-1 Retard Chamber is cast iron.

Valve Trim

The Valve Trim is illustrated in Figures 4A through 11B. The Valve Trim forms a part of the laboratory approval of the Model AV-1-300 Alarm Valve and is necessary for the proper operation of the Model AV-1-300 Alarm Valve.

Each package of trim includes the following items:

- Water Supply Pressure Gauge
- System Pressure Gauge
- Main Drain / Alarm Test Valve
- Bypass Check Valve
- Automatic Drain Valve
- Waterflow Pressure Alarm Switch
- Retard Chamber, as applicable

Operating Principles

When the fire protection system is initially being pressurized, water will flow into the system until the water supply and system pressure become equalized, and the Spring closes the Clapper in the Alarm Valve. Once the pressures have stabilized, the Alarm Valve is in service and the centrally located groove in the Seat Ring is sealed. Consequently, with the Alarm Check Valve set for service, there is no flow through the alarm port to the alarm devices (that is, water motor alarm and/or pressure alarm switch).

When there is a steady flow of water into the sprinkler system due to a sprinkler operation, the Clapper opens as shown in Figure 3. Water is then permitted to flow into the centrally located groove in the Seat Ring and out through the alarm port towards the Automatic Drain Valve. When the flow from the alarm port exceeds the drain capacity of the Automatic Drain Valve, the Retard Chamber (where provided in the case of systems with variable pressure), begins to fill as a function of the amount of water that can pass through the Restriction. Subsequently, the water motor alarm and/or the pressure alarm switch will be actuated. The alarms will continue to actuate as long as the Clapper remains opened. Water in the alarm lines will automatically drain out through the Automatic Drain Valve when the Clapper closes (due to discontinuation in the flow of water into the sprinkler system).

In the case of variable pressure systems, slow as well as small transient increases in water supply pressure may continue to build up in the system (via the bypass check valve) without opening the Clapper. A transient surge in supply pressure which is sufficient to only momentarily open the Clapper will not cause a false alarm, and a portion of the increase in pressure will be trapped within the system, thus reducing the possibility of another opening. Any water in the alarm line is automatically drained, further reducing the possibility of a false alarm due to a successive transient surge in supply pressure.

Design Criteria

In planning the installation of the TYCO Model AV-1-300 Alarm Valve, consideration must be given to the disposal of the large quantities of water that may be associated with draining the system or performing a flow test.

The sprinkler system designer must be aware that the configuration of the piping network and its tendency to trap pockets of air (such as in the case of a peaked-roof gridded system) can affect the performance of the alarm system. Although a slight amount of trapped air is desirable to prevent significant pressure increases due to thermally induced expansion of the water, a large quantity of trapped air in a system may result in the possibility of an intermittent alarm.

The possibility of an intermittent alarm condition is a consequence of the fact that the flow out of the system through the test valve or a single sprinkler is very small relative to the flow that can be passed through the valve. This difference increases with valve size. If the system were free of trapped air, flow in would equal flow out and the Clapper would always stabilize at some open position (as needed to accommodate the required flow). With trapped air in the system, however, the Clapper first opens wider since the system initially demands greater flow until the air pockets are compressed (back to nearly the supply pressure), and then it will tend to return closer to the Seat Ring. If the volume of the air pockets is excessive, flow into the system can be momentarily reduced to nearly zero (once the air pockets are compressed) and the Clapper may close, causing flow to the alarms to be shutoff.

Once the Clapper has closed, sufficient water must flow out of the system before the Clapper will again open. A repetition of the above described condition is termed an intermittent alarm.

Using a vent (which can also serve as an end-of-line Inspector's Test Connection) piped from the top of a cross main or end of a branch line at the point most remote from the alarm valve, and filling the system slowly in accordance with the steps described in the Valve Setting Procedure section, can prevent an excessive amount of air from being trapped.

| Nominal Valve Size DN | Nominal Dimensions mm | | | | | | | | |
|-----------------------|-------------------------------------|--------|------|-----------------------------|--------|------|-----------------------------|--------|------|
| | ANSI B16.1 (Class 125) ¹ | | | ISO2084 (PN10) ² | | | ISO2084 (PN16) ³ | | |
| | Dim. A | Dim. B | Qty. | Dim. A | Dim. B | Qty. | Dim. A | Dim. B | Qty. |
| DN65 | 139,7 | 19,0 | 4 | Use ISO 2084 (PN16) | | | 145,0 | 18,0 | 4 |
| DN100 | 190,5 | 19,0 | 8 | | | | 180,0 | 18,0 | 8 |
| DN150 | 241,3 | 22,0 | 8 | | | | 240,0 | 22,0 | 8 |
| DN200 | 298,5 | 22,0 | 8 | 295,0 | 22,0 | 8 | 295,0 | 22,0 | 12 |

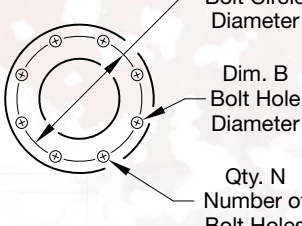

Dim. A Bolt Circle Diameter

Dim. B Bolt Hole Diameter

Qty. N Number of Bolt Holes

NOTES

1. Same drilling as for B16.5 (Class 150) and B16.42 (Class 150).
2. Same drilling as for B4504 Section 3.2 (PN10) and DIN2532 (PN10).
3. Same drilling as for B4504 Section 3.2 (PN16) and DIN 2532 (PN16).

TABLE B
MODEL AV-1-300 ALARM VALVE
FLANGE DRILLING SPECIFICATIONS

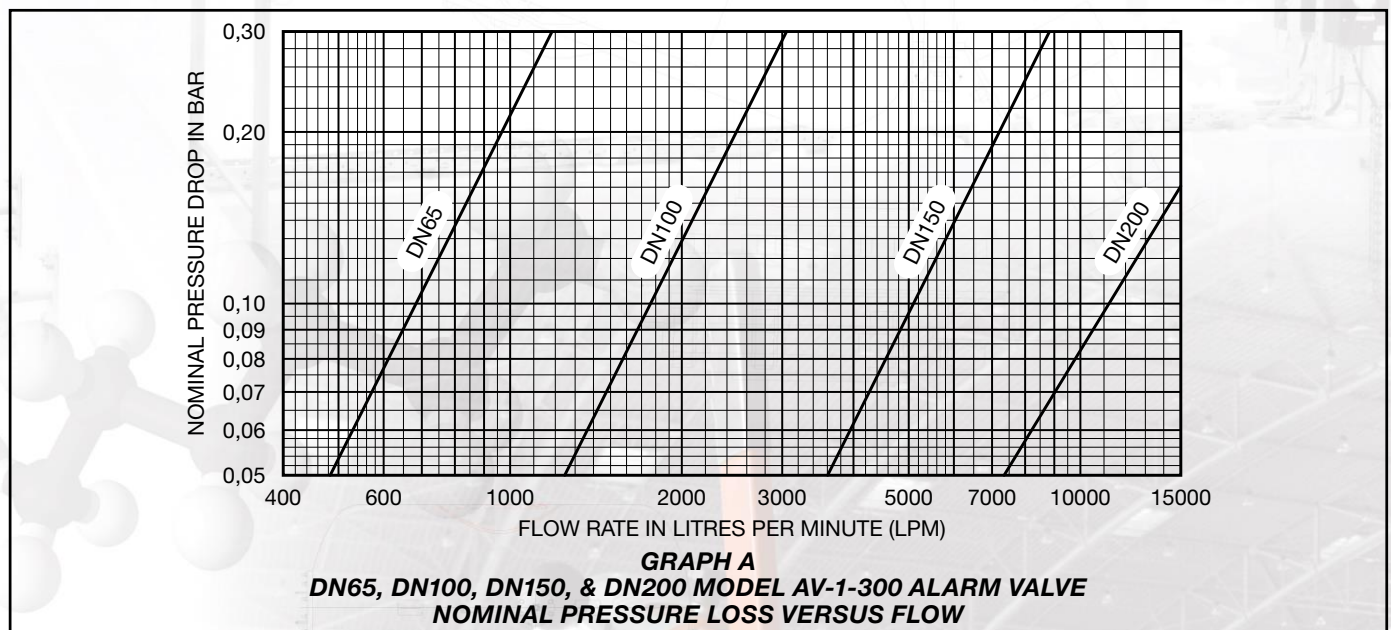

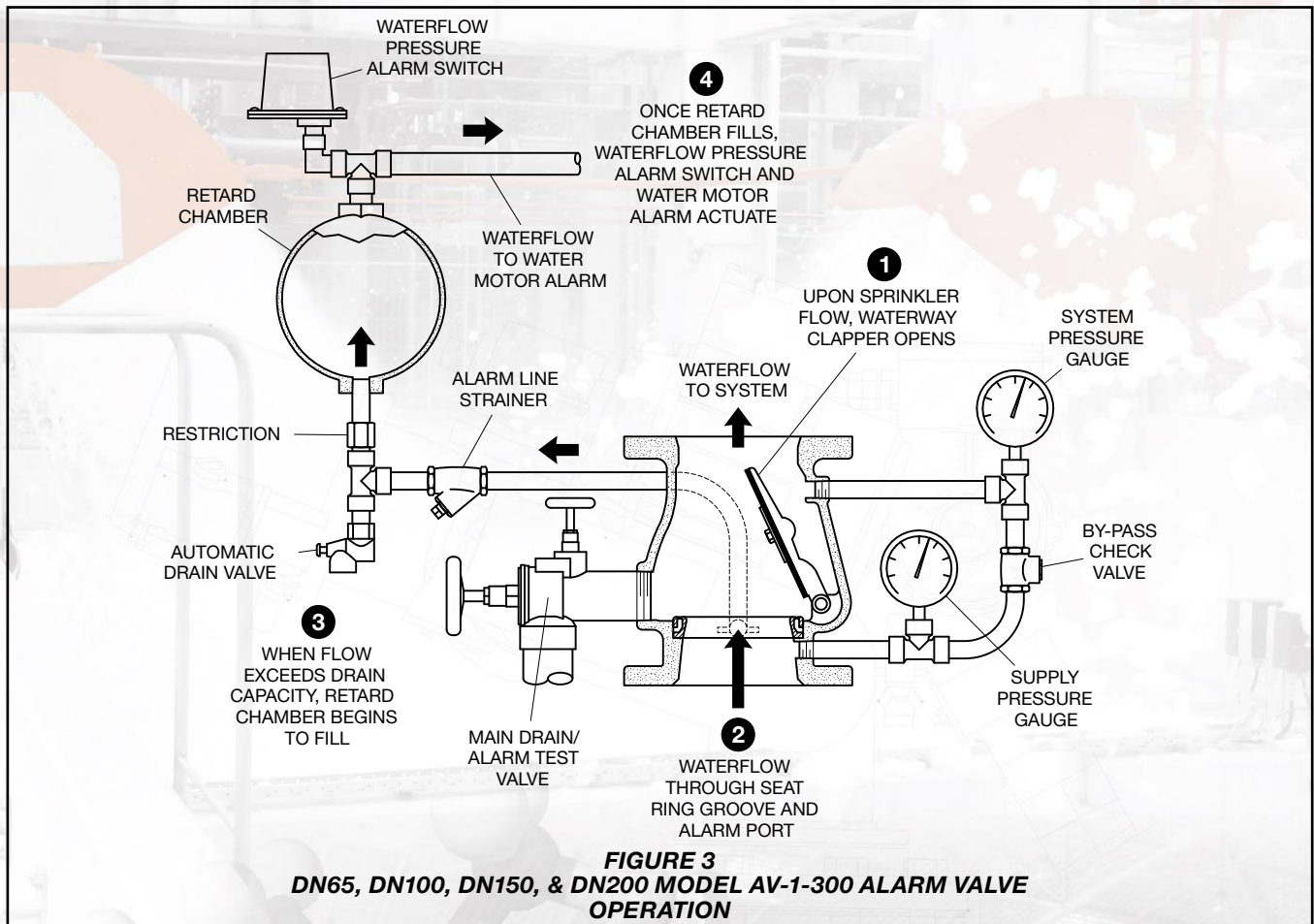

Installation

General Instructions

Proper operation of the TYCO Model AV-1-300 Alarm Valves depends upon its trim being installed in accordance with Figures 4A through 11B, as applicable. Failure to follow the appropriate trim diagram may prevent the valve from functioning, may void the Manufacturer's Warranty, and will void listings and approvals.

The Alarm Valves must be installed in readily visible and accessible locations.

It is recommended that provision be made for viewing the alarm line drain water by locating the drain outlet in a readily visible area.

Wet pipe fire protection systems must be maintained at a minimum temperature of 4°C.

Step 1. When trimming valves in the field (that is, other than valves provided with factory assembled trim), verify all nipples, fittings, and devices are clean and free of scale and burrs before installation. Use pipe-thread sealant sparingly on male pipe threads only.

Step 2. Plug unused alarm connections.

Step 3. Ensure suitable disposal of alarm line and system drainage water. Direct drainage water so that it will not cause damage or result in dangerous conditions.

Step 4. Position the alarm line drain so that there will be no danger of freezing.

Step 5. Install the check valve in the externally mounted bypass around the waterway clapper with its arrow pointed up.

Step 6. It is recommended that a vent connection, which may also be used as an end-of-line Inspector's Test Connection, be piped from a cross main or branch line at the point most remote from the alarm valve. Connect the vent line to the top of a cross main or to the end of a branch line. Position the vent line at the highest level of a multi-level installation.

The vent connection can be used to bleed-off excessive air from the system, and therefore, minimize the possibility of a false alarm due to a transient surge in supply pressure. The contraction/expansion associated with an excessive amount of trapped air could also cause the waterway Clapper to cycle open and shut during an inspector's test or during a discharge by a single sprinkler.

| NO. | DESCRIPTION | QTY. | P/N |
|-----|--|------|----------------|
| 1 | Pipe Nipple, 1/2" x 80mm Galvanized Steel | 2 | AP80D2 |
| 2 | Pipe Nipple, 1/2" x 60mm Galvanized Steel | 3 | AP60D2 |
| 3 | Pipe Nipple, 1-1/12" x 100mm Galvanized Steel | 1 | AP100H2 |
| 4 | Pipe Nipple, 1/2" x 100mm Galvanized Steel | 1 | AP100D2 |
| 5 | Elbow 90° M x F 1/2" BSP Galvanized | 3 | A92D2 |
| 6 | Elbow 45° F x F 1-1/2" BSP Galvanized | 1 | A41H2 |
| 7 | Union M x F 1/2" BSP Galvanized | 2 | A341D2 |
| 8 | Plug Male 1/4" BSP Galvanized | 1 | A290B2 |
| 9 | Nipple Male 1/2" BSP Galvanized | 2 | A280D2 |
| 10 | Nipple F x M 2" x 1-1/2" BSP Galvanized | 1 | A246IH2 |
| 11 | Nipple F x M 3/4" x 1/2" BSP Galvanized | 1 | A246ED2 |
| 12 | Nipple M x F 2" x 1-1/2" BSP Galvanized | 1 | A241IH2 |
| 13 | Nipple M x F 1/2" x 1/4" BSP Galvanized | 2 | A241DB2 |
| 14 | Tee M x F x F 1/2" BSP Galvanized | 2 | A134D2 |
| 15 | Tee M x F 1/2" BSP Galvanized | 1 | A133D2 |
| 16 | Reducing Tee Female 1/2" x 1/4" x 1/2" BSP Galvanized | 1 | A130RDBD2 |
| 17 | Tee Female 1/2" BSP Galvanized | 1 | A130D2 |
| 18 | Test and Drain Valve 2" NPT Inlet x 2" BSP Outlet x 1/2" Test Facility | 1 | 700487 |
| 19 | Ball Valve DN15-1/2" ISO 7/1 Full Bore PN40 Venthole Threaded M5 | 2 | 59304FO |
| 20 | Alarm Valve Model AV-1-300 2-1/2"/76,1mm G x G | 1 | 522034120 |
| 21 | Check Valve, Swing Type, 1/2" | 1 | 460491004D |
| 22 | Elbow WES 3mm x M5 | 2 | 406012 |
| 23 | Self-Closing Drain Valve 1/2" Brass | 1 | 2162156 |
| 24 | Ball Valve, DN15 - 1/2" BSP Full Bore | 1 | 1610000210 |
| 25 | Pressure Switch Model PS10-1 or TPS10X1 | 1 | 0260 or 100101 |
| 26 | Water Pressure Gauge 300 psi / 21 bar | 2 | 025500013 |
| 27 | Pressure Relief Hose 3 x 6 x 0,6m Transparent | 2 | CH |

Notes
a. CH: Common Hardware

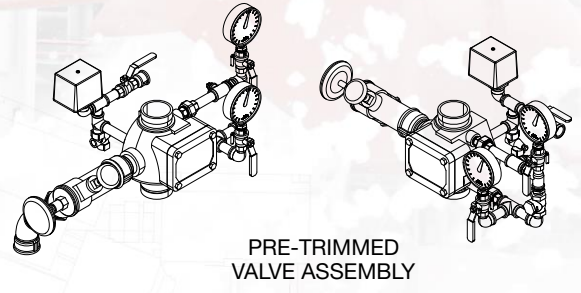

PRE-TRIMMED VALVE ASSEMBLY

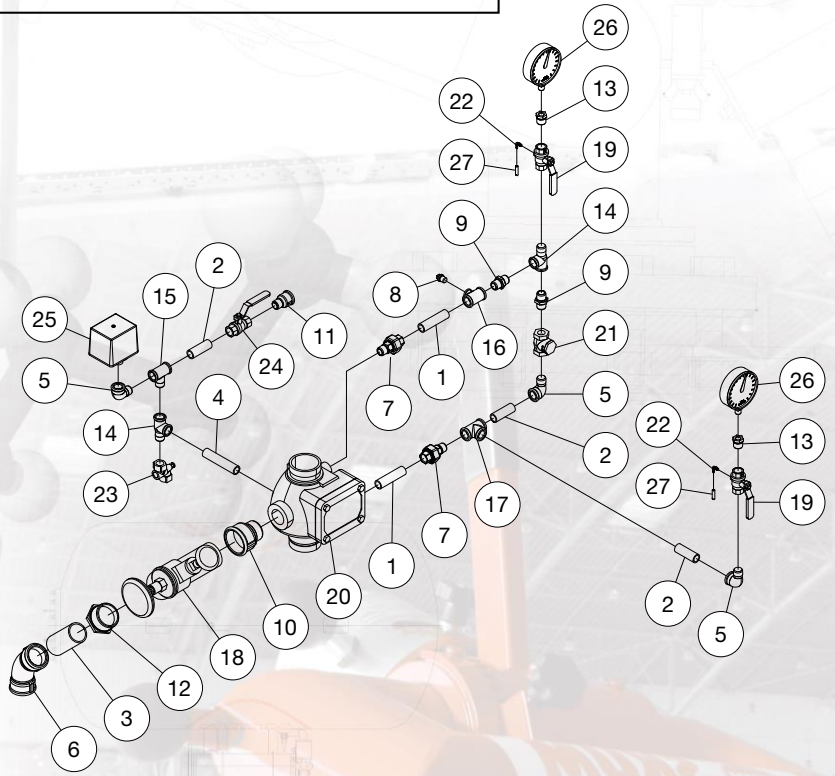
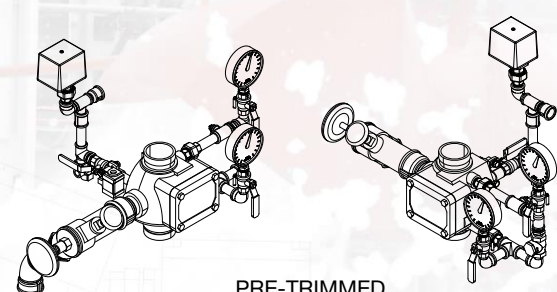

FIGURE 4A
DN65 MODEL AV-1-300 ALARM VALVE
TRIM ARRANGEMENT WITHOUT MODEL RC-1 RETARD CHAMBER

| NO. | DESCRIPTION | QTY. | P/N |
|-----|--|------|----------------|
| 1 | Pipe Nipple, 1/2" x 90mm Galvanized Steel | 1 | AP90D2 |
| 2 | Pipe Nipple, 1/2" x 80mm Galvanized Steel | 1 | AP80D2 |
| 3 | Pipe Nipple, 1/2" x 60mm Galvanized Steel | 2 | AP60D2 |
| 4 | Pipe Nipple, 1-1/2" x 100mm Galvanized Steel | 1 | AP100H2 |
| 5 | Elbow 90° M x F 1/2" BSP Galvanized | 3 | A92D2 |
| 6 | Elbow 45° F x F 1-1/2" BSP Galvanized | 1 | A41H2 |
| 7 | Union M x F 1/2" BSP Galvanized | 1 | A341D2 |
| 8 | Plug Male 1/4" BSP Galvanized | 1 | A290B2 |
| 9 | Nipple Male 1/2" BSP Galvanized | 1 | A280D2 |
| 10 | Coupling Female 1/2" BSP Galvanized | 1 | A270D2 |
| 11 | Nipple F x M 2" x 1-1/2" BSP Galvanized | 1 | A246IH2 |
| 12 | Nipple F x M 3/4" x 1/2" BSP Galvanized | 1 | A246ED2 |
| 13 | Nipple M x F 2" x 1-1/2" BSP Galvanized | 1 | A241IH2 |
| 14 | Nipple M x F 1/2" x 1/4" BSP Galvanized | 2 | A241DB2 |
| 15 | Tee M x F x F 1/2" BSP Galvanized | 2 | A134D2 |
| 16 | Tee M x F 1/2" BSP Galvanized | 1 | A133D2 |
| 17 | Reducing Tee Female 1/2" x 1/4" x 1/2" BSP Galvanized | 1 | A130RDBD2 |
| 18 | Tee Female 1/2" BSP Galvanized | 1 | A130D2 |
| 19 | Test and Drain Valve 2" NPT Inlet x 2" BSP Outlet x 1/2" Test Facility | 1 | 700487 |
| 20 | Ball Valve DN15-1/2" ISO 7/1 Full Bore PN40 Venthole Threaded M5 | 2 | 59304FO |
| 21 | Alarm Valve Model AV-1-300 2-1/2"/76,1mm G x G | 1 | 522034120 |
| 22 | Check Valve, Swing Type, 1/2" | 1 | 460491004D |
| 23 | Elbow WES 3mm x M5 | 2 | 406012 |
| 24 | Self-Closing Drain Valve 1/2" Brass | 1 | 2162156 |
| 25 | Ball Valve, DN15 - 1/2" BSP Full Bore | 1 | 1610000210 |
| 26 | Pressure Switch Model PS10-1 or TPS10X1 | 1 | 0260 or 100101 |
| 27 | Water Pressure Gauge 300 psi / 21 bar | 2 | 025500013 |
| 28 | Pressure Relief Hose 3 x 6 x 0,6m Transparent | 2 | CH |

Notes
 a. CH: Common Hardware



PRE-TRIMMED
 VALVE ASSEMBLY
 (SHOWN WITH
 SEPARATELY ORDERED
 SUPERVISORY SWITCH)

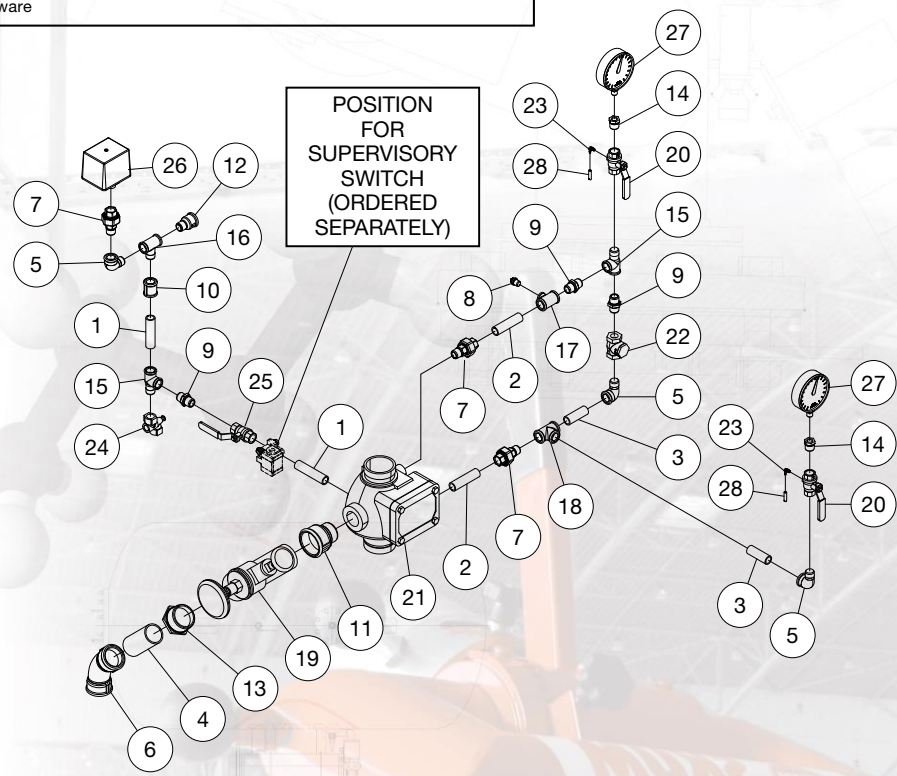

FIGURE 4B
DN65 MODEL AV-1-300 ALARM VALVE
TRIM ARRANGEMENT WITHOUT MODEL RC-1 RETARD CHAMBER
(SUITABLE FOR SUPERVISORY)

| NO. | DESCRIPTION | QTY. | P/N |
|-----|--|------|----------------|
| 1 | Pipe Nipple, 1/2" x 80mm Galvanized Steel | 2 | AP80D2 |
| 2 | Pipe Nipple, 1/2" x 60mm Galvanized Steel | 3 | AP60D2 |
| 3 | Pipe Nipple, 1/2" x 160mm Galvanized Steel | 1 | AP160D2 |
| 4 | Pipe Nipple, 1-1/2" x 100mm Galvanized Steel | 1 | AP100H2 |
| 5 | Elbow 90° M x F 1/2" BSP Galvanized | 3 | A92D2 |
| 6 | Elbow 45° F x F 1-1/2" BSP Galvanized | 1 | A41H2 |
| 7 | Union M x F 1/2" BSP Galvanized | 3 | A341D2 |
| 8 | Plug Male 1/4" BSP Galvanized | 1 | A290B2 |
| 9 | Nipple Male 3/4" BSP Galvanized | 1 | A280E2 |
| 10 | Nipple Male 1/2" BSP Galvanized | 4 | A280D2 |
| 11 | Nipple F x M 2" x 1-1/2" BSP Galvanized | 1 | A246IH2 |
| 12 | Nipple F x M 3/4" x 1/2" BSP Galvanized | 1 | A246ED2 |
| 13 | Nipple M x F 2" x 1-1/2" BSP Galvanized | 1 | A241IH2 |
| 14 | Nipple M x F 1/2" x 1/4" BSP Galvanized | 2 | A241DB2 |
| 15 | Tee M x F x F 1/2" BSP Galvanized | 2 | A134D2 |
| 16 | Reducing Tee Female 1/2" x 3/4" x 1/2" BSP Galvanized | 1 | A130RDED2 |
| 17 | Reducing Tee Female 1/2" x 1/4" x 1/2" BSP Galvanized | 1 | A130RDBD2 |
| 18 | Tee Female 1/2" BSP Galvanized | 1 | A130D2 |
| 19 | Test and Drain Valve 2" NPT Inlet x 2" BSP Outlet x 1/2" Test Facility | 1 | 700487 |
| 20 | Nipple M x F 1/2" x 3,56mm Orifice x 45,5mm | 1 | 700484 |
| 21 | Ball Valve DN15-1/2" ISO 7/1 Full Bore PN40 Venthole Threaded M5 | 1 | 59304FO |
| 22 | Retarding Chamber RC-1 | 1 | 522111002 |
| 23 | Alarm Valve Model AV-1-300 2-1/2"/76,1mm G x G | 1 | 522034120 |
| 24 | Check Valve, Swing Type, 1/2" | 1 | 460491004D |
| 25 | Elbow WES 3mm x M5 | 2 | 406012 |
| 26 | Strainer 1/2" Bronze | 1 | 305003 |
| 27 | Self-Closing Drain Valve 1/2" Brass | 1 | 2162156 |
| 28 | Ball Valve DN15-1/2" BSP Full Bore | 1 | 1610000210 |
| 29 | Pressure Switch Model PS10-1 or TPS10X1 | 1 | 0260 or 100101 |
| 30 | Water Pressure Gauge 300 psi / 21 bar | 2 | 025500013 |
| 31 | Pressure Relief Hose 3 x 6 x 0,6m Transparent | 2 | CH |

Notes
a. CH: Common Hardware

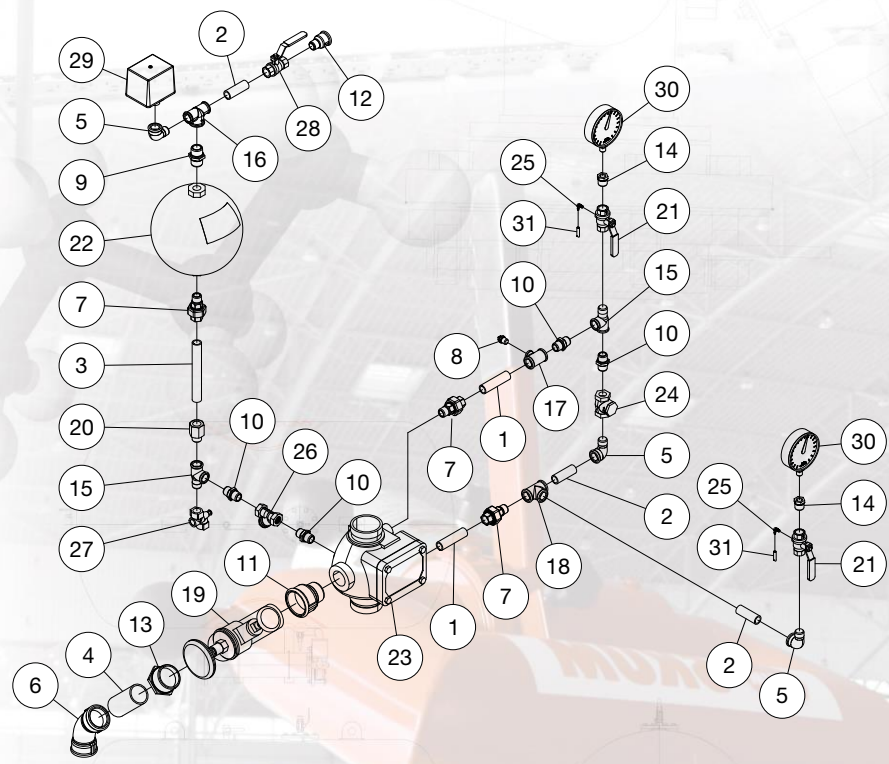
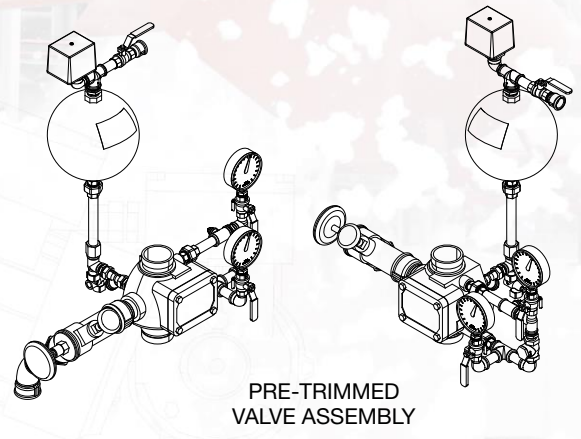

FIGURE 5A
DN65 MODEL AV-1-300 ALARM VALVE
TRIM ARRANGEMENT WITH MODEL RC-1 RETARD CHAMBER

| NO. | DESCRIPTION | QTY. | P/N |
|-----|--|------|----------------|
| 1 | Pressure Relief Hose 3 x 6 x 1,2m Transparent | 1 | WS00000004 |
| 2 | Pipe Nipple, 1/2" x 80mm Galvanized Steel | 2 | AP80D2 |
| 3 | Pipe Nipple, 1/2" x 60mm Galvanized Steel | 1 | AP60D2 |
| 4 | Pipe Nipple, 1-1/2" x 100mm Galvanized Steel | 1 | AP100H2 |
| 5 | Pipe Nipple, 1/2" x 100mm Galvanized Steel | 1 | AP100D2 |
| 6 | Elbow 90° M x F 1/2" BSP Galvanized | 3 | A92D2 |
| 7 | Elbow 45° F x F 1-1/2" BSP Galvanized | 1 | A41H2 |
| 8 | Union M x F 1/2" BSP Galvanized | 1 | A341D2 |
| 9 | Plug Male 1/4" BSP Galvanized | 1 | A290B2 |
| 10 | Nipple Male 3/4" BSP Galvanized | 1 | A280E2 |
| 11 | Nipple Male 1/2" BSP Galvanized | 4 | A280D2 |
| 12 | Nipple F x M 2" x 1-1/2" BSP Galvanized | 1 | A246IH2 |
| 13 | Nipple F x M 3/4" x 1/2" BSP Galvanized | 1 | A246ED2 |
| 14 | Nipple M x F 2" x 1-1/2" BSP Galvanized | 1 | A241IH2 |
| 15 | Nipple M x F 1/2" x 1/4" BSP Galvanized | 2 | A241DB2 |
| 16 | Tee M x F x F 1/2" BSP Galvanized | 2 | A134D2 |
| 17 | Reducing Tee Female 1/2" x 3/4" x 1/2" BSP Galvanized | 1 | A130RDED2 |
| 18 | Reducing Tee Female 1/2" x 1/4" x 1/2" BSP Galvanized | 1 | A130RDBD2 |
| 19 | Tee Female 1/2" BSP Galvanized | 1 | A130D2 |
| 20 | Test and Drain Valve 2" NPT Inlet x 2" BSP Outlet x 1/2" Test Facility | 1 | 700487 |
| 21 | Nipple M x F 1/2" x 3,56mm Orifice x 45,5mm | 1 | 700484 |
| 22 | Ball Valve DN15-1/2" ISO 7/1 Full Bore PN40 Venthole Threaded M5 | 1 | 59304FO |
| 23 | Retarding Chamber RC-1 | 1 | 522111002 |
| 24 | Alarm Valve Model AV-1-300 2-1/2"/76,1mm G x G | 1 | 522034120 |
| 25 | Check Valve, Swing Type, 1/2" | 1 | 460491004D |
| 26 | Elbow WES 3mm x M5 | 1 | 406012 |
| 27 | Strainer 1/2" Bronze | 1 | 305003 |
| 28 | Self-Closing Drain Valve 1/2" Brass | 1 | 2162156 |
| 29 | Pressure Switch Model PS10-1 or TPS10X1 | 1 | 0260 or 100101 |
| 30 | Water Pressure Gauge 300 psi / 21 bar | 2 | 025500013 |
| 31 | Pressure Relief Hose 3 x 6 x 0,6m Transparent | 2 | CH |

Notes

a. CH: Common Hardware



 PRE-TRIMMED
 VALVE ASSEMBLY
 (SHOWN WITH
 SEPARATELY ORDERED
 SUPERVISORY SWITCH)

FIGURE 5B
DN65 MODEL AV-1-300 ALARM VALVE
TRIM ARRANGEMENT WITH MODEL RC-1 RETARD CHAMBER
(SUITABLE FOR SUPERVISORY)

| NO. | DESCRIPTION | QTY. | P/N |
|-----|--|------|----------------|
| 1 | Pipe Nipple, 1/2" x 90mm Galvanized Steel | 2 | AP90D2 |
| 2 | Pipe Nipple, 1/2" x 60mm Galvanized Steel | 2 | AP60D2 |
| 3 | Pipe Nipple, 2" x 200mm Galvanized Steel | 1 | AP200I2 |
| 4 | Pipe Nipple, 1/2" x 120mm Galvanized Steel | 2 | AP120D2 |
| 5 | Elbow 90° M x F 1/2" BSP Galvanized | 3 | A92D2 |
| 6 | Union M x F 1/2" BSP Galvanized | 3 | A341D2 |
| 7 | Plug Male 1/2" BSP Galvanized | 1 | A291D2 |
| 8 | Nipple F x M 3/4" x 1/2" BSP Galvanized | 1 | A246ED2 |
| 9 | Nipple M x F 1/2" x 1/4" BSP Galvanized | 2 | A241DB2 |
| 10 | Tee M x F x F 1/2" BSP Galvanized | 2 | A134D2 |
| 11 | Tee M x F 1/2" BSP Galvanized | 1 | A133D2 |
| 12 | Tee M x F 1/2" BSP Galvanized | 1 | A133D2 |
| 13 | Test and Drain Valve 2" NPT Inlet x 2" BSP Outlet x 1/2" Test Facility | 1 | 700487 |
| 14 | Ball Valve DN15-1/2" ISO 7/1 Full Bore PN40 Venthole Threaded M5 | 2 | 59304FO |
| 15 | Alarm Valve Model AV-1-300 4"/114,3mm G x G. | 1 | 522031923 |
| 16 | Check Valve, Swing Type, 1/2" | 1 | 460491004D |
| 17 | Elbow WES 3mm x M5. | 2 | 406012 |
| 18 | Self-Closing Drain Valve 1/2" Brass | 1 | 2162156 |
| 19 | Ball Valve, DN15 - 1/2" BSP Full Bore | 1 | 1610000210 |
| 20 | Pressure Switch Model PS10-1 or TPS10X1 | 1 | 0260 or 100103 |
| 21 | Water Pressure Gauge 300 psi / 21 bar | 2 | 025500013 |
| 22 | Pressure Relief Hose 3 x 6 x 0,6m Transparent | 2 | CH |

Notes
 a. CH: Common Hardware

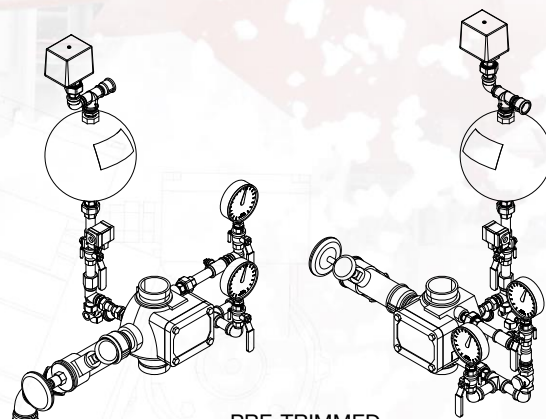
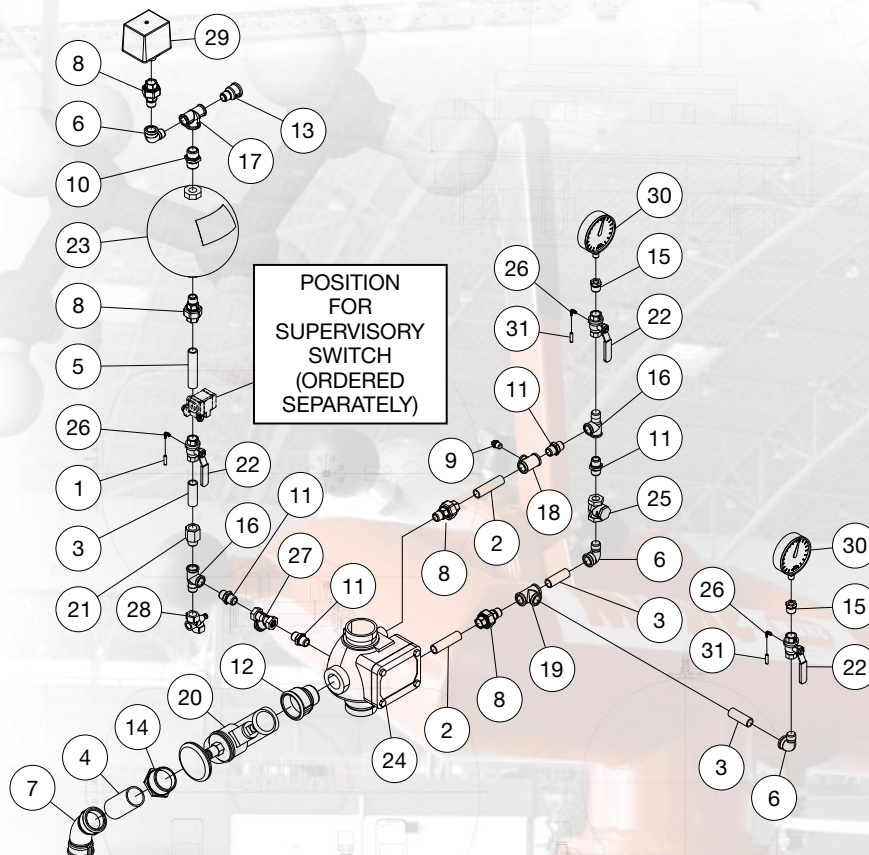
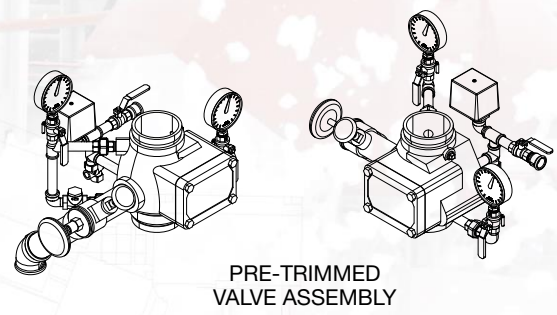

PRE-TRIMMED
 VALVE ASSEMBLY

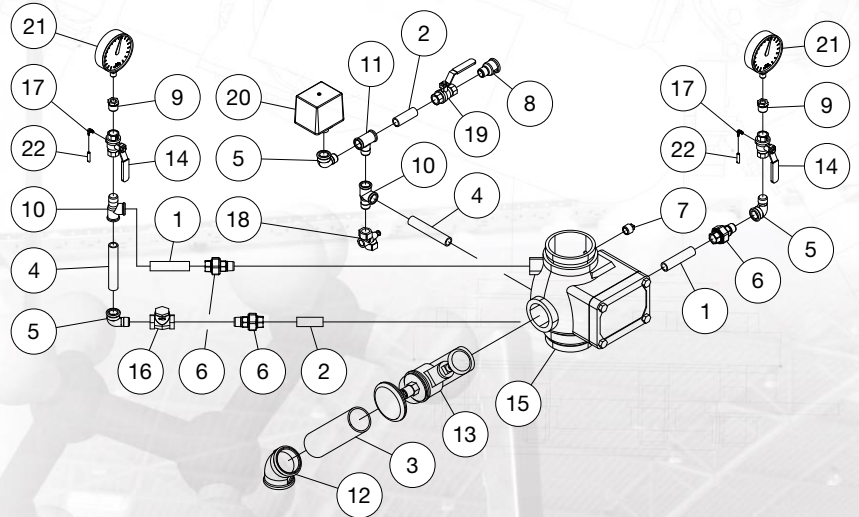
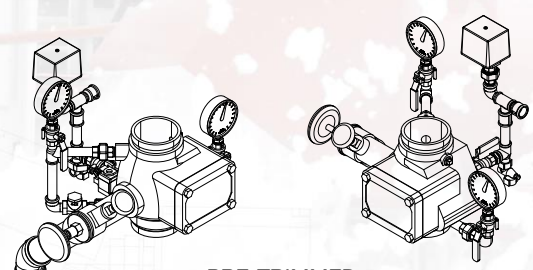

FIGURE 6A
DN100 MODEL AV-1-300 ALARM VALVE
TRIM ARRANGEMENT WITHOUT MODEL RC-1 RETARD CHAMBER

| NO. | DESCRIPTION | QTY. | P/N |
|-----|--|------|----------------|
| 1 | Pipe Nipple, 1/2" x 90mm Galvanized Steel | 1 | AP90D2 |
| 2 | Pipe Nipple, 1/2" x 80mm Galvanized Steel | 1 | AP80D2 |
| 3 | Pipe Nipple, 1/2" x 60mm Galvanized Steel | 1 | AP60D2 |
| 4 | Pipe Nipple, 2" x 200mm Galvanized Steel | 1 | AP200I2 |
| 5 | Pipe Nipple, 1/2" x 120mm Galvanized Steel | 1 | AP120D2 |
| 6 | Elbow 90° M x F 1/2" BSP Galvanized | 3 | A92D2 |
| 7 | Union M x F 1/2" BSP Galvanized | 1 | A341D2 |
| 8 | Plug Male 1/2" BSP Galvanized | 1 | A291D2 |
| 9 | Nipple Male 1/2" BSP Galvanized | 1 | A280D2 |
| 10 | Coupling Female 1/2" BSP Galvanized | 1 | A270D2 |
| 11 | Nipple F x M 3/4" x 1/2" BSP Galvanized | 1 | A246ED2 |
| 12 | Nipple M x F 1/2" x 1/4" BSP Galvanized | 2 | A241DB2 |
| 13 | Tee M x F x F 1/2" BSP Galvanized | 2 | A134D2 |
| 14 | Tee M x F 1/2" BSP Galvanized | 1 | A133D2 |
| 15 | Elbow 45° F x F 2" BSP Galvanized | 1 | A120I2 |
| 16 | Test and Drain Valve 2" NPT Inlet x 2" BSP Outlet x 1/2" Test Facility | 1 | 700487 |
| 17 | Ball Valve DN15-1/2" ISO 7/1 Full Bore PN40 Venthole Threaded M5 | 2 | 59304FO |
| 18 | Alarm Valve Model AV-1-300 4"/114,3mm G x G. | 1 | 522031923 |
| 19 | Check Valve, Swing Type, 1/2" | 1 | 460491004D |
| 20 | Elbow WES 3mm x M5 | 2 | 406012 |
| 21 | Self-Closing Drain Valve 1/2" Brass | 1 | 2162156 |
| 22 | Ball Valve, DN15 - 1/2" BSP Full Bore | 1 | 161000210 |
| 23 | Pressure Switch Model PS10-1 or TPS10X1 | 1 | 0260 or 100101 |
| 24 | Water Pressure Gauge 300 psi / 21 bar | 2 | 025500013 |
| 25 | Pressure Relief Hose 3 x 6 x 0,6m Transparent | 2 | CH |

Notes
 a. CH: Common Hardware



PRE-TRIMMED VALVE ASSEMBLY (SHOWN WITH SEPARATELY ORDERED SUPERVISORY SWITCH)

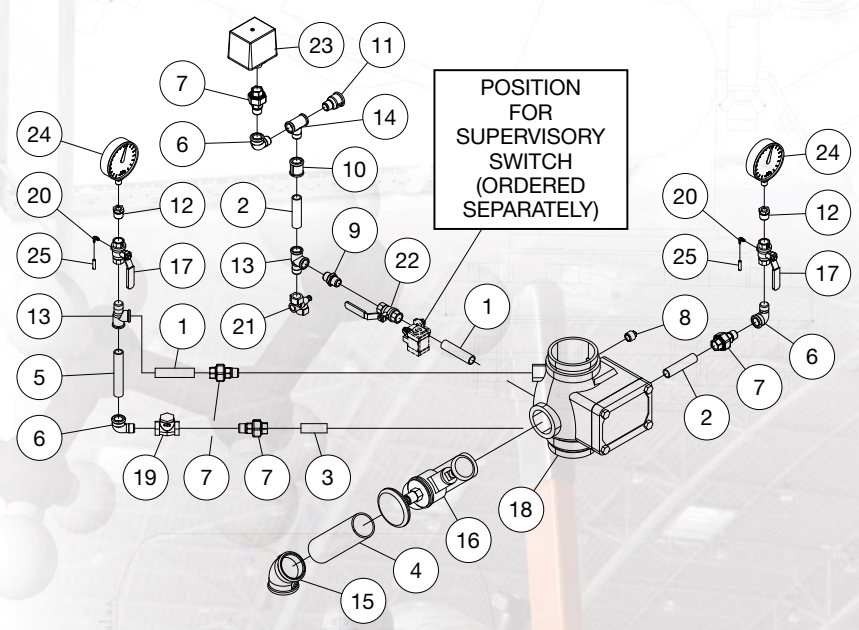
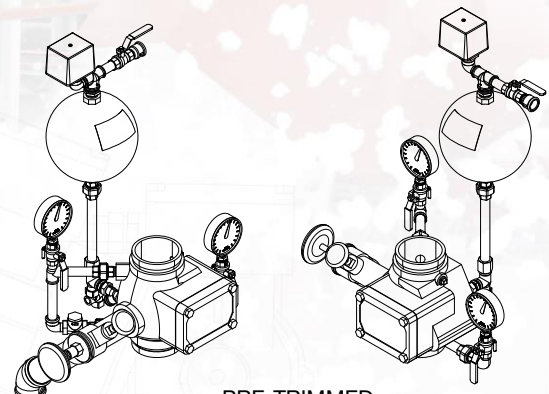

FIGURE 6B
DN100 MODEL AV-1-300 ALARM VALVE
TRIM ARRANGEMENT WITHOUT MODEL RC-1 RETARD CHAMBER
(SUITABLE FOR SUPERVISORY)

| NO. | DESCRIPTION | QTY. | P/N |
|-----|--|------|----------------|
| 1 | Pipe Nipple, 1/2" x 90mm Galvanized Steel | 2 | AP90D2 |
| 2 | Pipe Nipple, 1/2" x 60mm Galvanized Steel | 2 | AP60D2 |
| 3 | Pipe Nipple, 2" x 200mm Galvanized Steel | 1 | AP200I2 |
| 4 | Pipe Nipple, 1/2" x 200mm Galvanized Steel | 1 | AP200D2 |
| 5 | Pipe Nipple, 1/2" x 120mm Galvanized Steel | 1 | AP120D2 |
| 6 | Elbow 90° M x F 1/2" BSP Galvanized | 3 | A92D2 |
| 7 | Union M x F 1/2" BSP Galvanized | 4 | A341D2 |
| 8 | Plug Male 1/2" BSP Galvanized | 1 | A291D2 |
| 9 | Nipple Male 3/4" BSP Galvanized | 1 | A280E2 |
| 10 | Nipple Male 1/2" BSP Galvanized | 2 | A280D2 |
| 11 | Nipple F x M 3/4" x 1/2" BSP Galvanized | 1 | A246ED2 |
| 12 | Nipple M x F 1/2" x 1/4" BSP Galvanized | 2 | A241DB2 |
| 13 | Tee M x F x F 1/2" BSP Galvanized | 2 | A134D2 |
| 14 | Reducing Tee Female 1/2" x 3/4" x 1/2" BSP Galvanized | 1 | A130RDED2 |
| 15 | Elbow 45° F x F 2" BSP Galvanized | 1 | A120I2 |
| 16 | Test and Drain Valve 2" NPT Inlet x 2" BSP Outlet x 1/2" Test Facility | 1 | 700487 |
| 17 | Nipple M x F 1/2" x 3,56mm Orifice x 45,5mm | 1 | 700484 |
| 18 | Ball Valve DN15-1/2" ISO 7/1 Full Bore PN40 Venthole Threaded M5 | 2 | 59304FO |
| 19 | Retarding Chamber RC-1 | 1 | 522111002 |
| 20 | Alarm Valve Model AV-1-300 4"/114,3mm G x G | 1 | 522031923 |
| 21 | Check Valve, Swing Type, 1/2" | 1 | 460491004D |
| 22 | Elbow WES 3mm x M5 | 2 | 406012 |
| 23 | Strainer 1/2" Bronze | 1 | 305003 |
| 24 | Self-Closing Drain Valve 1/2" Brass | 1 | 2162156 |
| 25 | Ball Valve DN15-1/2" BSP Full Bore | 1 | 1610000210 |
| 26 | Pressure Switch Model PS10-1 or TPS10X1 | 1 | 0260 or 100101 |
| 27 | Water Pressure Gauge 300 psi / 21 bar | 2 | 025500013 |
| 28 | Pressure Relief Hose 3 x 6 x 0,6m Transparent | 2 | CH |

Notes
 a. CH: Common Hardware



PRE-TRIMMED VALVE ASSEMBLY

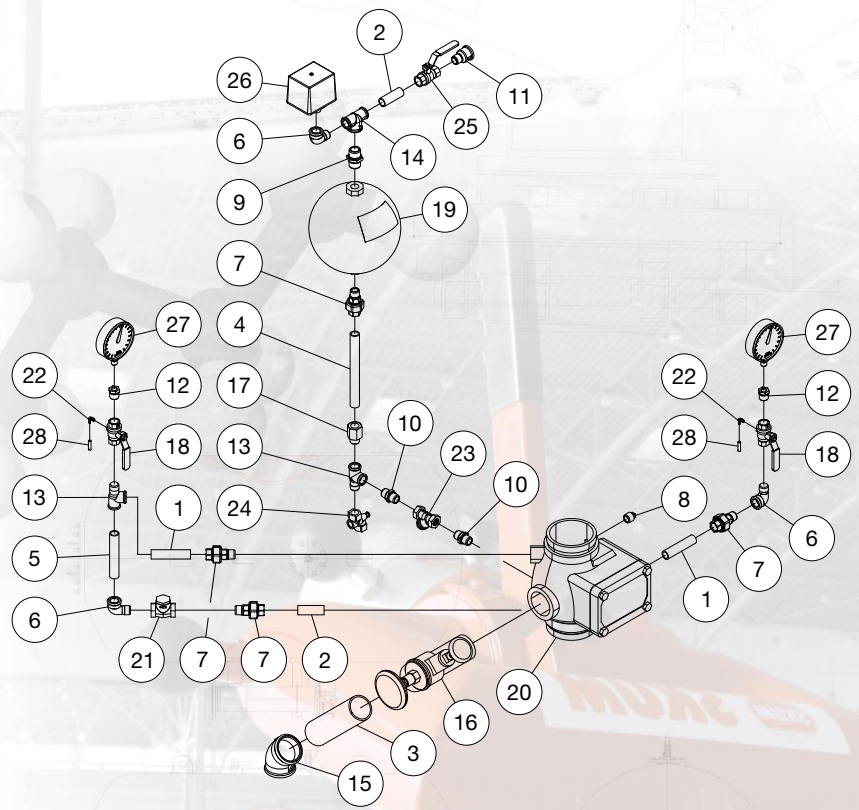
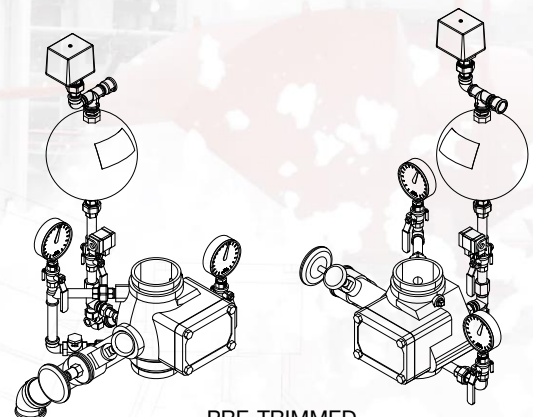

FIGURE 7A
DN100 MODEL AV-1-300 ALARM VALVE TRIM ARRANGEMENT WITH MODEL RC-1 RETARD CHAMBER

| NO. | DESCRIPTION | QTY. | P/N |
|-----|--|------|----------------|
| 1 | Pressure Relief Hose 3 x 6 x 1,2m Transparent | 1 | WS00000004 |
| 2 | Pipe Nipple, 1/2" x 90mm Galvanized Steel | 2 | AP90D2 |
| 3 | Pipe Nipple, 1/2" x 60mm Galvanized Steel | 1 | AP60D2 |
| 4 | Pipe Nipple, 2" x 200mm Galvanized Steel | 1 | AP200I2 |
| 5 | Pipe Nipple, 1/2" x 120mm Galvanized Steel | 1 | AP120D2 |
| 6 | Elbow 90° M x F 1/2" BSP Galvanized | 3 | A92D2 |
| 7 | Union M x F 1/2" BSP Galvanized | 1 | A341D2 |
| 8 | Plug Male 1/2" BSP Galvanized | 1 | A291D2 |
| 9 | Nipple Male 3/4" BSP Galvanized | 1 | A280E2 |
| 10 | Nipple Male 1/2" BSP Galvanized | 2 | A280D2 |
| 11 | Nipple F x M 3/4" x 1/2" BSP Galvanized | 1 | A246ED2 |
| 12 | Nipple M x F 1/2" x 1/4" BSP Galvanized | 2 | A241DB2 |
| 13 | Tee M x F x F 1/2" BSP Galvanized | 2 | A134D2 |
| 14 | Reducing Tee Female 1/2" x 3/4" x 1/2" BSP Galvanized | 1 | A130RDE2 |
| 15 | Elbow 45° F x F 2" BSP Galvanized | 1 | A120I2 |
| 16 | Test and Drain Valve 2" NPT Inlet x 2" BSP Outlet x 1/2" Test Facility | 1 | 700487 |
| 17 | Nipple M x F 1/2" x 3,56mm Orifice x 45,5mm | 1 | 700484 |
| 18 | Ball Valve DN15-1/2" ISO 7/1 Full Bore PN40 Venthole Threaded M5 | 1 | 59304FO |
| 19 | Retarding Chamber RC-1 | 1 | 522111002 |
| 20 | Alarm Valve Model AV-1-300 4"/114,3mm G x G | 1 | 522031923 |
| 21 | Check Valve, Swing Type, 1/2" | 1 | 460491004D |
| 22 | Elbow WES 3mm x M5 | 1 | 406012 |
| 23 | Strainer 1/2" Bronze | 1 | 305003 |
| 24 | Self-Closing Drain Valve 1/2" Brass | 1 | 2162156 |
| 25 | Pressure Switch Model PS10-1 or TPS10X1 | 1 | 0260 or 100101 |
| 26 | Water Pressure Gauge 300 psi / 21 bar | 2 | 025500013 |
| 27 | Pressure Relief Hose 3 x 6 x 0,6m Transparent | 2 | CH |

Notes
a. CH: Common Hardware



PRE-TRIMMED VALVE ASSEMBLY (SHOWN WITH SEPARATELY ORDERED SUPERVISORY SWITCH)

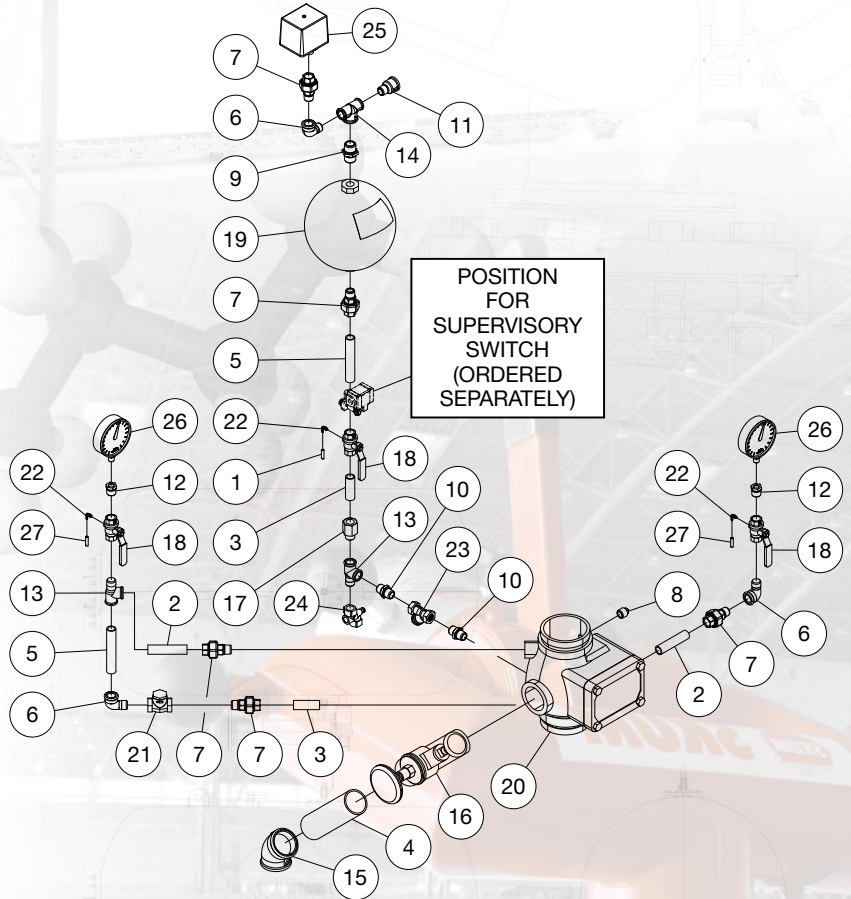
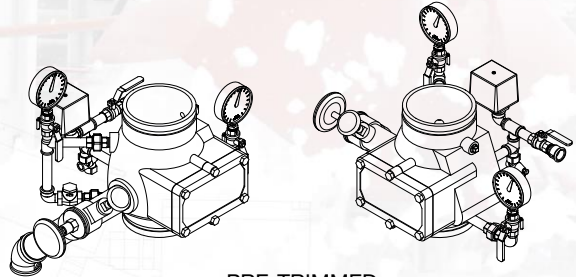

FIGURE 7B
DN100 MODEL AV-1-300 ALARM VALVE TRIM ARRANGEMENT WITH MODEL RC-1 RETARD CHAMBER (SUITABLE FOR SUPERVISORY)

| NO. | DESCRIPTION | QTY. | P/N |
|-----|--|------|----------------|
| 1 | Pipe Nipple, 1/2" x 90mm Galvanized Steel | 2 | AP90D2 |
| 2 | Pipe Nipple, 1/2" x 60mm Galvanized Steel | 2 | AP60D2 |
| 3 | Pipe Nipple, 2" x 200mm Galvanized Steel | 1 | AP200I2 |
| 4 | Pipe Nipple, 1/2" x 120mm Galvanized Steel | 2 | AP120D2 |
| 5 | Elbow 90° M x F 1/2" BSP Galvanized | 3 | A92D2 |
| 6 | Union M x F 1/2" BSP Galvanized | 3 | A341D2 |
| 7 | Plug Male 1/2" BSP Galvanized | 1 | A291D2 |
| 8 | Nipple F x M 3/4" x 1/2" BSP Galvanized | 1 | A246ED2 |
| 9 | Nipple M x F 1/2" x 1/4" BSP Galvanized | 2 | A241DB2 |
| 10 | Tee M x F x F 1/2" BSP Galvanized | 2 | A134D2 |
| 11 | Tee M x F 1/2" BSP Galvanized | 1 | A133D2 |
| 12 | Elbow 45° F x F 2" BSP Galvanized | 1 | A120I2 |
| 13 | Test and Drain Valve 2" NPT Inlet x 2" BSP Outlet x 1/2" Test Facility | 1 | 700487 |
| 14 | Ball Valve DN15-1/2" ISO 7/1 Full Bore PN40 Venthole Threaded M5 | 2 | 59304FO |
| 15 | Alarm Valve Model AV-1-300 6"/168,3mm G x G | 1 | 522031925 |
| 16 | Check Valve, Swing Type, 1/2" | 1 | 460491004D |
| 17 | Elbow WES 3mm x M5 | 2 | 406012 |
| 18 | Self-Closing Drain Valve 1/2" Brass | 1 | 2162156 |
| 19 | Ball Valve, DN15 - 1/2" BSP Full Bore | 1 | 1610000210 |
| 20 | Pressure Switch Model PS10-1 or TPS10X1 | 1 | 0260 or 100101 |
| 21 | Water Pressure Gauge 300 psi / 21 bar | 2 | 025500013 |
| 22 | Pressure Relief Hose 3 x 6 x 0,6m Transparent | 2 | CH |

Notes
 a. CH: Common Hardware



PRE-TRIMMED
VALVE ASSEMBLY

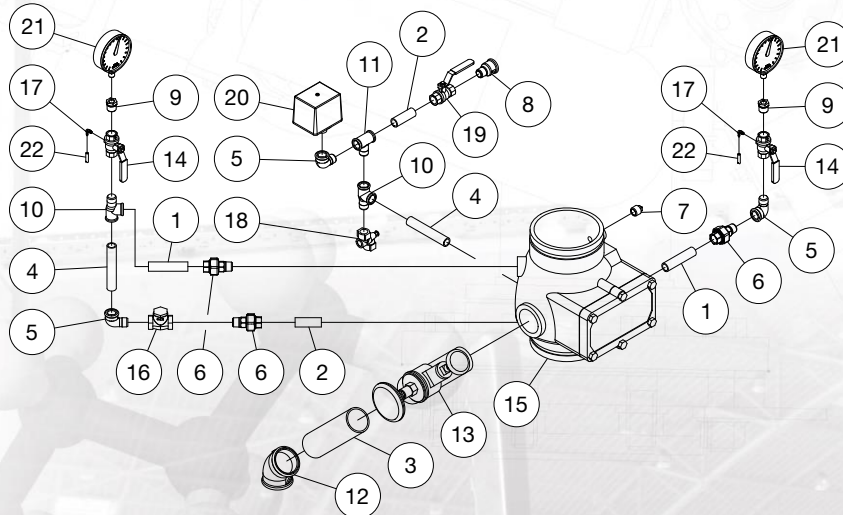
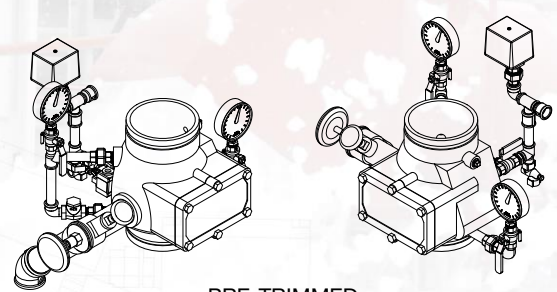

FIGURE 8A
DN150 MODEL AV-1-300 ALARM VALVE
TRIM ARRANGEMENT WITHOUT MODEL RC-1 RETARD CHAMBER

| NO. | DESCRIPTION | QTY. | P/N |
|-----|--|------|----------------|
| 1 | Pipe Nipple, 1/2" x 90mm Galvanized Steel | 1 | AP90D2 |
| 2 | Pipe Nipple, 1/2" x 80mm Galvanized Steel | 1 | AP80D2 |
| 3 | Pipe Nipple, 1/2" x 60mm Galvanized Steel | 1 | AP60D2 |
| 4 | Pipe Nipple, 2" x 200mm Galvanized Steel | 1 | AP200I2 |
| 5 | Pipe Nipple, 1/2" x 120mm Galvanized Steel | 1 | AP120D2 |
| 6 | Elbow 90° M x F 1/2" BSP Galvanized | 3 | A92D2 |
| 7 | Union M x F 1/2" BSP Galvanized | 1 | A341D2 |
| 8 | Plug Male 1/2" BSP Galvanized | 1 | A291D2 |
| 9 | Nipple Male 1/2" BSP Galvanized | 1 | A280D2 |
| 10 | Coupling Female 1/2" BSP Galvanized | 1 | A270D2 |
| 11 | Nipple F x M 3/4" x 1/2" BSP Galvanized | 1 | A246ED2 |
| 12 | Nipple M x F 1/2" x 1/4" BSP Galvanized | 2 | A241DB2 |
| 13 | Tee M x F x F 1/2" BSP Galvanized | 2 | A134D2 |
| 14 | Tee M x F 1/2" BSP Galvanized | 1 | A133D2 |
| 15 | Elbow 45° F x F 2" BSP Galvanized | 1 | A120I2 |
| 16 | Test and Drain Valve 2" NPT Inlet x 2" BSP Outlet x 1/2" Test Facility | 1 | 700487 |
| 17 | Ball Valve DN15-1/2" ISO 7/1 Full Bore PN40 Venthole Threaded M5 | 2 | 59304FO |
| 18 | Alarm Valve Model AV-1-300 6"/168,3mm G x G | 1 | 522031925 |
| 19 | Check Valve, Swing Type, 1/2" | 1 | 460491004D |
| 20 | Elbow WES 3mm x M5 | 2 | 406012 |
| 21 | Self-Closing Drain Valve 1/2" Brass | 1 | 2162156 |
| 22 | Ball Valve, DN15 - 1/2" BSP Full Bore | 1 | 1610000210 |
| 23 | Pressure Switch Model PS10-1 or TPS10X1 | 1 | 0260 or 100101 |
| 24 | Water Pressure Gauge 300 psi / 21 bar | 2 | 025500013 |
| 25 | Pressure Relief Hose 3 x 6 x 0,6m Transparent | 2 | CH |

Notes
 a. CH: Common Hardware



PRE-TRIMMED
 VALVE ASSEMBLY
 (SHOWN WITH
 SEPARATELY ORDERED
 SUPERVISORY SWITCH)

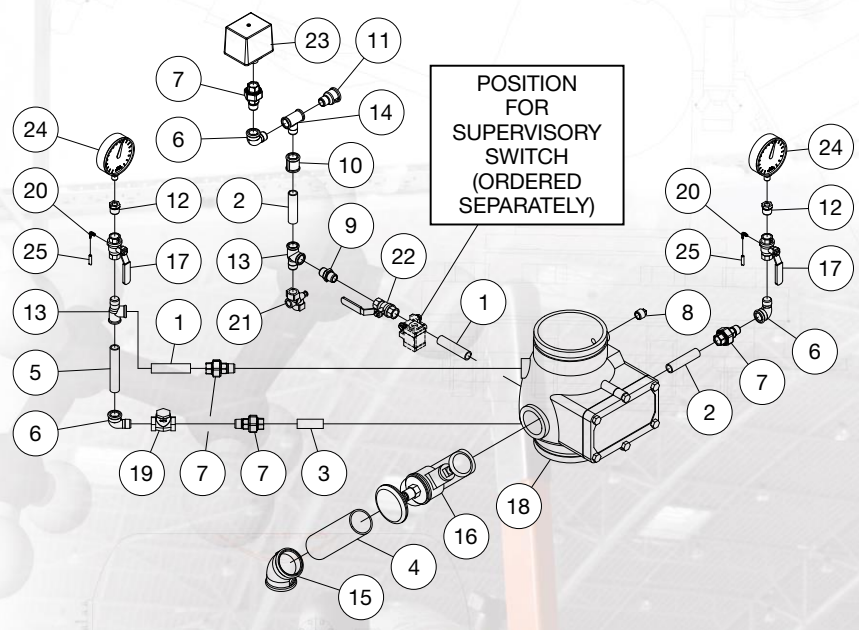
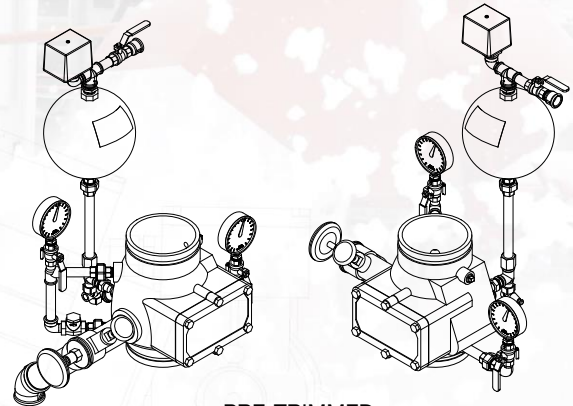

FIGURE 8B
DN150 MODEL AV-1-300 ALARM VALVE
TRIM ARRANGEMENT WITHOUT MODEL RC-1 RETARD CHAMBER
(SUITABLE FOR SUPERVISORY)

| NO. | DESCRIPTION | QTY. | P/N |
|-----|--|------|----------------|
| 1 | Pipe Nipple, 1/2" x 90mm Galvanized Steel | 2 | AP90D2 |
| 2 | Pipe Nipple, 1/2" x 60mm Galvanized Steel | 2 | AP60D2 |
| 3 | Pipe Nipple, 2" x 200mm Galvanized Steel | 1 | AP200I2 |
| 4 | Pipe Nipple, 1/2" x 200mm Galvanized Steel | 1 | AP200D2 |
| 5 | Pipe Nipple, 1/2" x 120mm Galvanized Steel | 1 | AP120D2 |
| 6 | Elbow 90° M x F 1/2" BSP Galvanized. | 3 | A92D2 |
| 7 | Union M x F 1/2" BSP Galvanized | 4 | A341D2 |
| 8 | Plug Male 1/2" BSP Galvanized | 1 | A291D2 |
| 9 | Nipple Male 3/4" BSP Galvanized | 1 | A280E2 |
| 10 | Nipple Male 1/2" BSP Galvanized | 2 | A280D2 |
| 11 | Nipple F x M 3/4" x 1/2" BSP Galvanized | 1 | A246ED2 |
| 12 | Nipple M x F 1/2" x 1/4" BSP Galvanized | 2 | A241DB2 |
| 13 | Tee M x F x F 1/2" BSP Galvanized | 2 | A134D2 |
| 14 | Reducing Tee Female 1/2" x 3/4" x 1/2" BSP Galvanized | 1 | A130RDED2 |
| 15 | Elbow 45° F x F 2" BSP Galvanized | 1 | A120I2 |
| 16 | Test and Drain Valve 2" NPT Inlet x 2" BSP Outlet x 1/2" Test Facility | 1 | 700487 |
| 17 | Nipple M x F 1/2" x 3,56mm Orifice x 45,5mm | 1 | 700484 |
| 18 | Ball Valve DN15-1/2" ISO 7/1 Full Bore PN40 Venthole Threaded M5 | 2 | 59304FO |
| 19 | Retarding Chamber RC-1 | 1 | 522111002 |
| 20 | Alarm Valve Model AV-1-300 6"/168,3mm G x G | 1 | 522031925 |
| 21 | Check Valve, Swing Type, 1/2" | 1 | 460491004D |
| 22 | Elbow WES 3mm x M5 | 2 | 406012 |
| 23 | Strainer 1/2" Bronze | 1 | 305003 |
| 24 | Self-Closing Drain Valve 1/2" Brass | 1 | 2162156 |
| 25 | Ball Valve DN15-1/2" BSP Full Bore | 1 | 1610000210 |
| 26 | Pressure Switch Model PS10-1 or TPS10X1 | 1 | 0260 or 100101 |
| 27 | Water Pressure Gauge 300 psi / 21 bar | 2 | 025500013 |
| 28 | Pressure Relief Hose 3 x 6 x 0,6m Transparent | 2 | CH |

Notes
a. CH: Common Hardware



PRE-TRIMMED VALVE ASSEMBLY

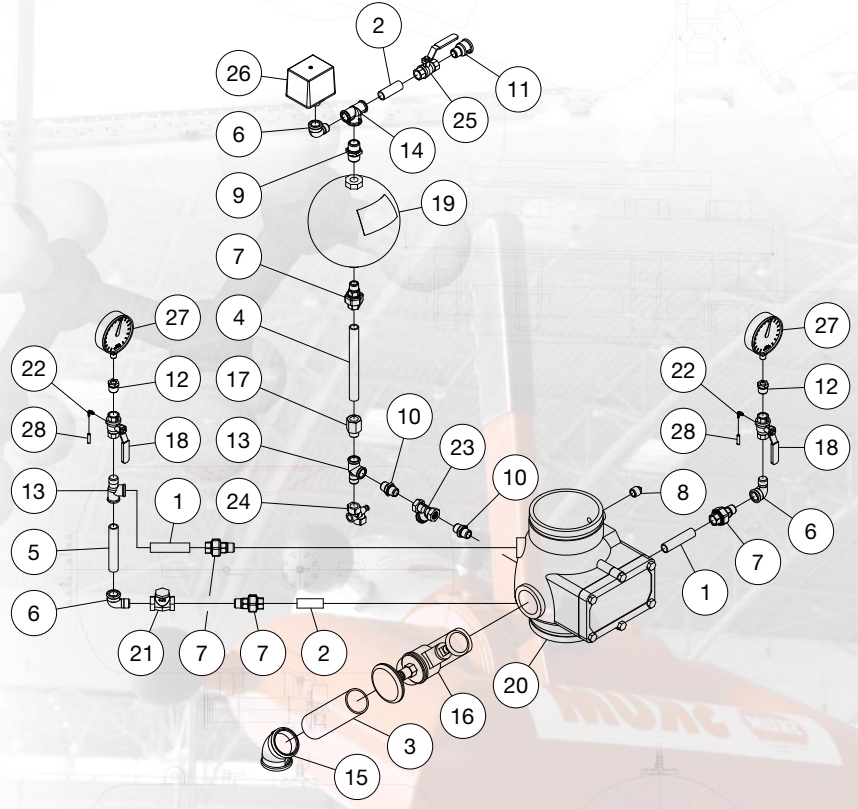
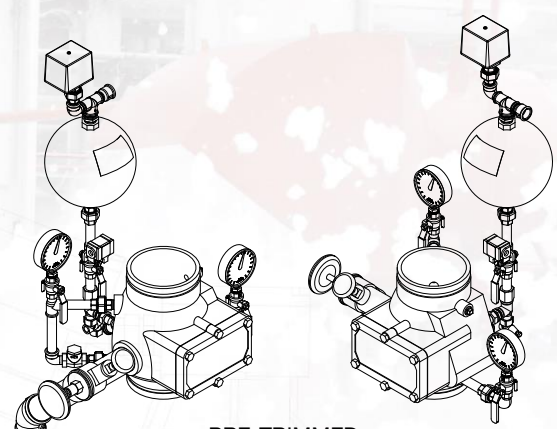

FIGURE 9A
DN150 MODEL AV-1-300 ALARM VALVE
TRIM ARRANGEMENT WITH MODEL RC-1 RETARD CHAMBER

| NO. | DESCRIPTION | QTY. | P/N |
|-----|--|------|----------------|
| 1 | Pressure Relief Hose 3 x 6 x 1,2m Transparent | 1 | WS00000004 |
| 2 | Pipe Nipple, 1/2" x 90mm Galvanized Steel | 2 | AP90D2 |
| 3 | Pipe Nipple, 1/2" x 60mm Galvanized Steel | 1 | AP60D2 |
| 4 | Pipe Nipple, 2" x 200mm Galvanized Steel | 1 | AP200I2 |
| 5 | Pipe Nipple, 1/2" x 120mm Galvanized Steel | 1 | AP120D2 |
| 6 | Elbow 90° M x F 1/2" BSP Galvanized | 3 | A92D2 |
| 7 | Union M x F 1/2" BSP Galvanized | 1 | A341D2 |
| 8 | Plug Male 1/2" BSP Galvanized | 1 | A291D2 |
| 9 | Nipple Male 3/4" BSP Galvanized | 1 | A280E2 |
| 10 | Nipple Male 1/2" BSP Galvanized | 2 | A280D2 |
| 11 | Nipple F x M 3/4" x 1/2" BSP Galvanized | 1 | A246ED2 |
| 12 | Nipple M x F 1/2" x 1/4" BSP Galvanized | 2 | A241DB2 |
| 13 | Tee M x F x F 1/2" BSP Galvanized | 2 | A134D2 |
| 14 | Reducing Tee Female 1/2" x 3/4" x 1/2" BSP Galvanized | 1 | A130RDED2 |
| 15 | Elbow 45° F x F 2" BSP Galvanized | 1 | A120I2 |
| 16 | Test and Drain Valve 2" NPT Inlet x 2" BSP Outlet x 1/2" Test Facility | 1 | 700487 |
| 17 | Nipple M x F 1/2" x 3,56mm Orifice x 45,5mm | 1 | 700484 |
| 18 | Ball Valve DN15-1/2" ISO 7/1 Full Bore PN40 Venthole Threaded M5 | 1 | 59304FO |
| 19 | Retarding Chamber RC-1 | 1 | 522111002 |
| 20 | Alarm Valve Model AV-1-300 6"/168,3mm G x G. | 1 | 522031925 |
| 21 | Check Valve, Swing Type, 1/2" | 1 | 460491004D |
| 22 | Elbow WES 3mm x M5 | 1 | 406012 |
| 23 | Strainer 1/2" Bronze | 1 | 305003 |
| 24 | Self-Closing Drain Valve 1/2" Brass | 1 | 2162156 |
| 25 | Pressure Switch Model PS10-1 or TPS10X1 | 1 | 0260 or 100101 |
| 26 | Water Pressure Gauge 300 psi / 21 bar | 2 | 025500013 |
| 27 | Pressure Relief Hose 3 x 6 x 0,6m Transparent | 2 | CH |

Notes
 a. CH: Common Hardware



PRE-TRIMMED
 VALVE ASSEMBLY
 (SHOWN WITH
 SEPARATELY ORDERED
 SUPERVISORY SWITCH)

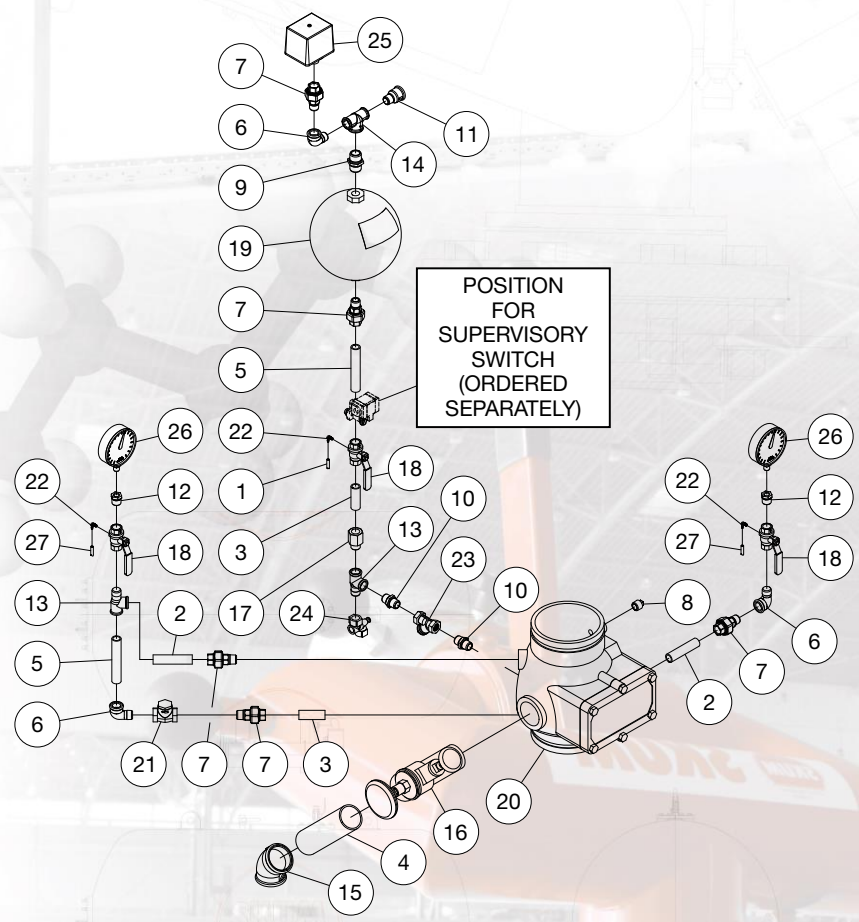

FIGURE 9B
DN150 MODEL AV-1-300 ALARM VALVE
TRIM ARRANGEMENT WITH MODEL RC-1 RETARD CHAMBER
(SUITABLE FOR SUPERVISORY)

| NO. | DESCRIPTION | QTY. | P/N |
|-----|--|------|----------------|
| 1 | Pipe Nipple, 1/2" x 60mm Galvanized Steel | 1 | AP60D2 |
| 2 | Pipe Nipple, 2" x 200mm Galvanized Steel | 1 | AP200I2 |
| 3 | Pipe Nipple, 3/4" x 160mm Galvanized Steel | 1 | AP160E2 |
| 4 | Pipe Nipple, 3/4" x 120mm Galvanized Steel | 1 | AP120E2 |
| 5 | Pipe Nipple, 1/2" x 120mm Galvanized Steel | 1 | AP120D2 |
| 6 | Pipe Nipple, 3/4" x 110mm Galvanized Steel | 1 | AP110E2 |
| 7 | Elbow 90° M x F 3/4" BSP Galvanized | 1 | A92E2 |
| 8 | Elbow 90° M x F 1/2" BSP Galvanized | 2 | A92D2 |
| 9 | Plug Male 3/4" BSP Galvanized | 2 | A596E2 |
| 10 | Union M x F 3/4" BSP Galvanized | 2 | A341E2 |
| 11 | Nipple F x M 3/4" x 1/2" BSP Galvanized | 1 | A246ED2 |
| 12 | Nipple M x F 3/4" x 1/2" BSP Galvanized | 2 | A245ED2 |
| 13 | Nipple M x F 1/2" x 1/4" BSP Galvanized | 2 | A241DB2 |
| 14 | Tee M x F x F 3/4" BSP Galvanized | 1 | A134E2 |
| 15 | Tee M x F x F 1/2" BSP Galvanized | 1 | A134D2 |
| 16 | Tee M x F 1/2" BSP Galvanized | 1 | A133D2 |
| 17 | Tee Female 3/4" BSP Galvanized | 1 | A130E2 |
| 18 | Elbow 45° F x F 2" BSP Galvanized | 1 | A120I2 |
| 19 | Test and Drain Valve 2" NPT Inlet x 2" BSP Outlet x 1/2" Test Facility | 1 | 700487 |
| 20 | Ball Valve DN15-1/2" ISO 7/1 Full Bore PN40 Venthole Threaded M5 | 2 | 59304FO |
| 21 | Alarm Valve Model AV-1-300 8" G x G | 1 | 522031926 |
| 22 | Check Valve, Swing Type, 3/4" | 1 | 460491005 |
| 23 | Elbow WES 3mm x M5 | 2 | 406012 |
| 24 | Self-Closing Drain Valve 1/2" Brass | 1 | 2162156 |
| 25 | Ball Valve, DN15 - 1/2" BSP Full Bore | 1 | 1610000210 |
| 26 | Pressure Switch Model PS10-1 or TPS10X1 | 1 | 0260 or 100101 |
| 27 | Water Pressure Gauge 300 psi / 21 bar | 2 | 025500013 |
| 28 | Pressure Relief Hose 3 x 6 x 0,6m Transparent | 2 | CH |

Notes
 a. CH: Common Hardware

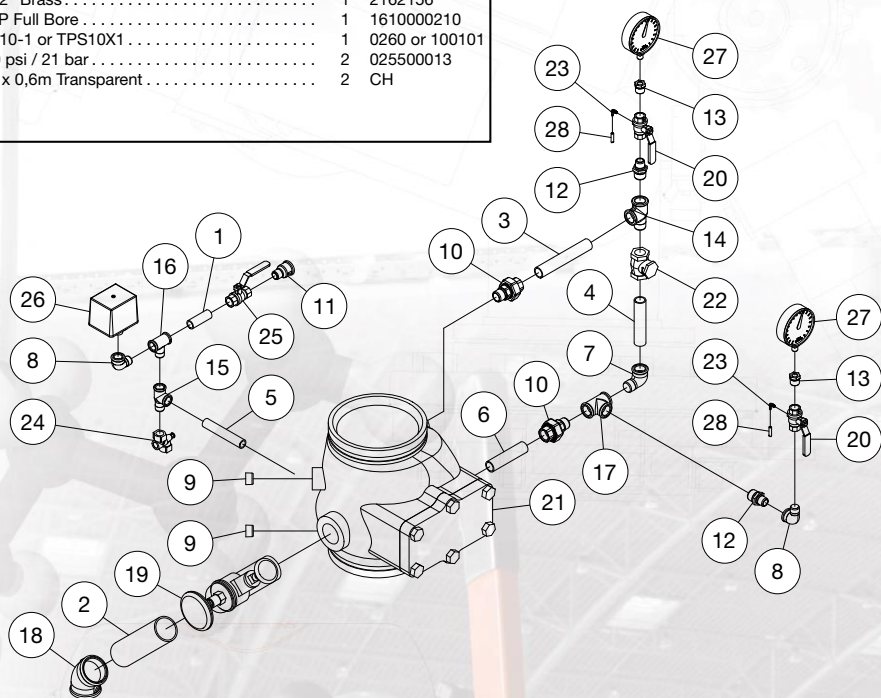
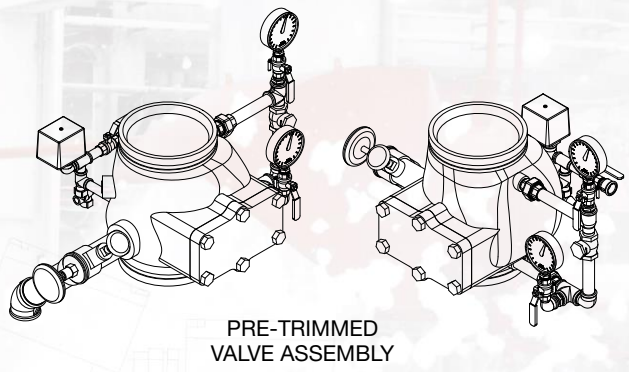
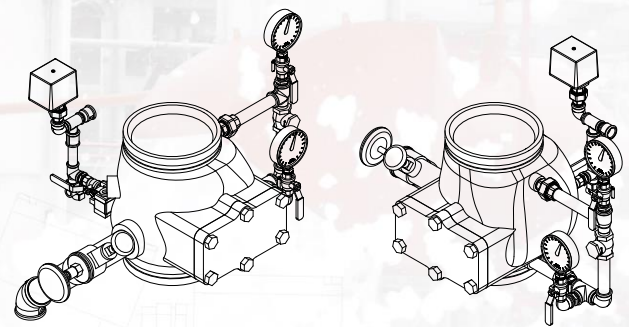

FIGURE 10A
DN200 MODEL AV-1-300 ALARM VALVE
TRIM ARRANGEMENT WITHOUT MODEL RC-1 RETARD CHAMBER

| NO. | DESCRIPTION | QTY. | P/N |
|-----|--|------|----------------|
| 1 | Pipe Nipple, 1/2" x 90mm Galvanized Steel | 1 | AP90D2 |
| 2 | Pipe Nipple, 1/2" x 80mm Galvanized Steel | 1 | AP80D2 |
| 3 | Pipe Nipple, 2" x 200mm Galvanized Steel | 1 | AP200I2 |
| 4 | Pipe Nipple, 3/4" x 160mm Galvanized Steel | 1 | AP160E2 |
| 5 | Pipe Nipple, 3/4" x 120mm Galvanized Steel | 1 | AP120E2 |
| 6 | Pipe Nipple, 3/4" x 110mm Galvanized Steel | 1 | AP110E2 |
| 7 | Elbow 90° M x F 3/4" BSP Galvanized | 1 | A92E2 |
| 8 | Elbow 90° M x F 1/2" BSP Galvanized | 2 | A92D2 |
| 9 | Plug Male 3/4" BSP Galvanized | 2 | A596E2 |
| 10 | Union M x F 3/4" BSP Galvanized | 2 | A341E2 |
| 11 | Union M x F 1/2" BSP Galvanized | 1 | A341D2 |
| 12 | Nipple Male 1/2" BSP Galvanized | 1 | A280D2 |
| 13 | Coupling Female 1/2" BSP Galvanized | 1 | A270D2 |
| 14 | Nipple F x M 3/4" x 1/2" BSP Galvanized | 1 | A246ED2 |
| 15 | Nipple M x F 3/4" x 1/2" BSP Galvanized | 2 | A245ED2 |
| 16 | Nipple M x F 1/2" x 1/4" BSP Galvanized | 2 | A241DB2 |
| 17 | Tee M x F x F 3/4" BSP Galvanized | 1 | A134E2 |
| 18 | Tee M x F x F 1/2" BSP Galvanized | 1 | A134D2 |
| 19 | Tee M x F 1/2" BSP Galvanized | 1 | A133D2 |
| 20 | Tee Female 3/4" BSP Galvanized | 1 | A130E2 |
| 21 | Elbow 45° F x F 2" BSP Galvanized | 1 | A120I2 |
| 22 | Test and Drain Valve 2" NPT Inlet x 2" BSP Outlet x 1/2" Test Facility | 1 | 700487 |
| 23 | Ball Valve DN15-1/2" ISO 7/1 Full Bore PN40 Venthole Threaded M5 | 2 | 59304FO |
| 24 | Alarm Valve Model AV-1-300 8" G x G | 1 | 522031926 |
| 25 | Check Valve, Swing Type, 3/4" | 1 | 460491005 |
| 26 | Elbow WES 3mm x M5 | 2 | 406012 |
| 27 | Self-Closing Drain Valve 1/2" Brass | 1 | 2162156 |
| 28 | Ball Valve, DN15 - 1/2" BSP Full Bore | 1 | 1610000210 |
| 29 | Pressure Switch Model PS10-1 or TPS10X1 | 1 | 0260 or 100101 |
| 30 | Water Pressure Gauge 300 psi / 21 bar | 2 | 025500013 |
| 31 | Pressure Relief Hose 3 x 6 x 0,6m Transparent | 2 | CH |

Notes
a. CH: Common Hardware



PRE-TRIMMED
VALVE ASSEMBLY
(SHOWN WITH
SEPARATELY ORDERED
SUPERVISORY SWITCH)

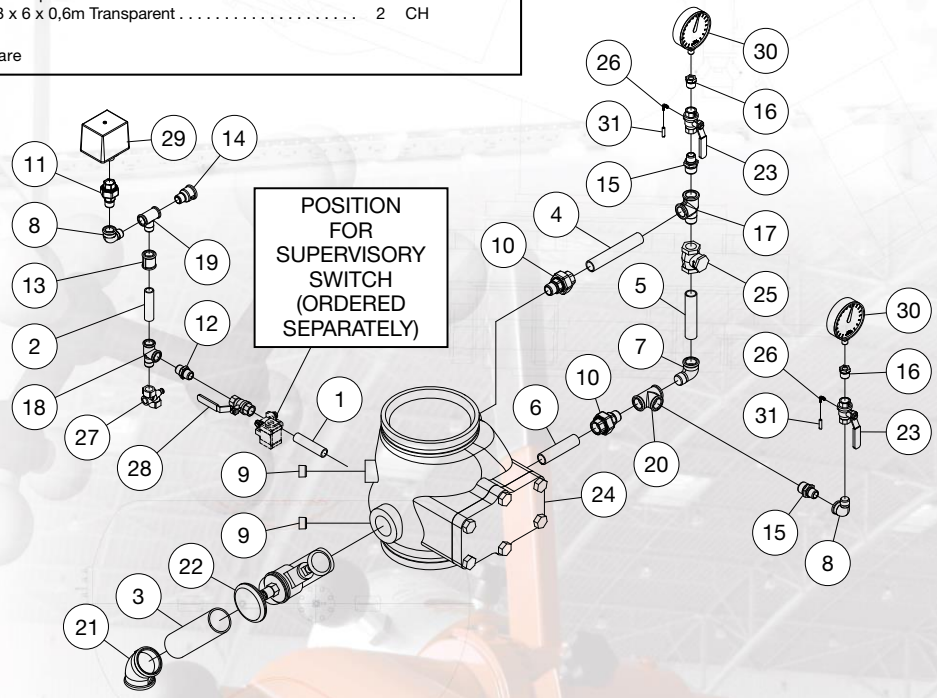

FIGURE 10B
DN200 MODEL AV-1-300 ALARM VALVE
TRIM ARRANGEMENT WITHOUT MODEL RC-1 RETARD CHAMBER
(SUITABLE FOR SUPERVISORY)

| NO. | DESCRIPTION | QTY. | P/N |
|-----|--|------|----------------|
| 1 | Pipe Nipple, 1/2" x 60mm Galvanized Steel | 2 | AP60D2 |
| 2 | Pipe Nipple, 2" x 200mm Galvanized Steel | 1 | AP200I2 |
| 3 | Pipe Nipple, 1/2" x 200mm Galvanized Steel | 1 | AP200D2 |
| 4 | Pipe Nipple, 3/4" x 160mm Galvanized Steel | 1 | AP160E2 |
| 5 | Pipe Nipple, 3/4" x 120mm Galvanized Steel | 1 | AP120E2 |
| 6 | Pipe Nipple, 3/4" x 110mm Galvanized Steel | 1 | AP110E2 |
| 7 | Elbow 90° M x F 3/4" BSP Galvanized | 1 | A92E2 |
| 8 | Elbow 90° M x F 1/2" BSP Galvanized | 2 | A92D2 |
| 9 | Plug Male 3/4" BSP Galvanized | 2 | A596E2 |
| 10 | Union M x F 3/4" BSP Galvanized | 2 | A341E2 |
| 11 | Union M x F 1/2" BSP Galvanized | 1 | A341D2 |
| 12 | Nipple Male 3/4" BSP Galvanized | 1 | A280E2 |
| 13 | Nipple Male 1/2" BSP Galvanized | 1 | A280D2 |
| 14 | Nipple F x M 3/4" x 1/2" BSP Galvanized | 1 | A246ED2 |
| 15 | Nipple M x F 3/4" x 1/2" BSP Galvanized | 2 | A245ED2 |
| 16 | Nipple M x F 1/2" x 1/4" BSP Galvanized | 2 | A241DB2 |
| 17 | Tee M x F x F 3/4" BSP Galvanized | 1 | A134E2 |
| 18 | Tee M x F x F 1/2" BSP Galvanized | 1 | A134D2 |
| 19 | Reducing Tee Female 1/2" x 3/4" x 1/2" BSP Galvanized | 1 | A130RDED2 |
| 20 | Tee Female 3/4" BSP Galvanized | 1 | A130E2 |
| 21 | Elbow 45° F x F 2" BSP Galvanized | 1 | A120I2 |
| 22 | Test and Drain Valve 2" NPT Inlet x 2" BSP Outlet x 1/2" Test Facility | 1 | 700487 |
| 23 | Nipple M x F 1/2" x 3,56mm Orifice x 45,5mm | 1 | 700484 |
| 24 | Ball Valve DN15-1/2" ISO 7/1 Full Bore PN40 Venthole Threaded M5 | 2 | 59304FO |
| 25 | Retarding Chamber RC-1 | 1 | 522111002 |
| 26 | Alarm Valve Model AV-1-300 8" G x G. | 1 | 522031926 |
| 27 | Check Valve, Swing Type, 3/4" | 1 | 460491005 |
| 28 | Elbow WES 3mm x M5 | 2 | 406012 |
| 29 | Strainer 1/2" Bronze | 1 | 305003 |
| 30 | Self-Closing Drain Valve 1/2" Brass | 1 | 2162156 |
| 31 | Ball Valve DN15-1/2" BSP Full Bore | 1 | 1610000210 |
| 32 | Pressure Switch Model PS10-1 or TPS10X1 | 1 | 0260 or 100101 |
| 33 | Water Pressure Gauge 300 psi / 21 bar | 2 | 025500013 |
| 34 | Pressure Relief Hose 3 x 6 x 0,6m Transparent | 2 | CH |

Notes
a. CH: Common Hardware

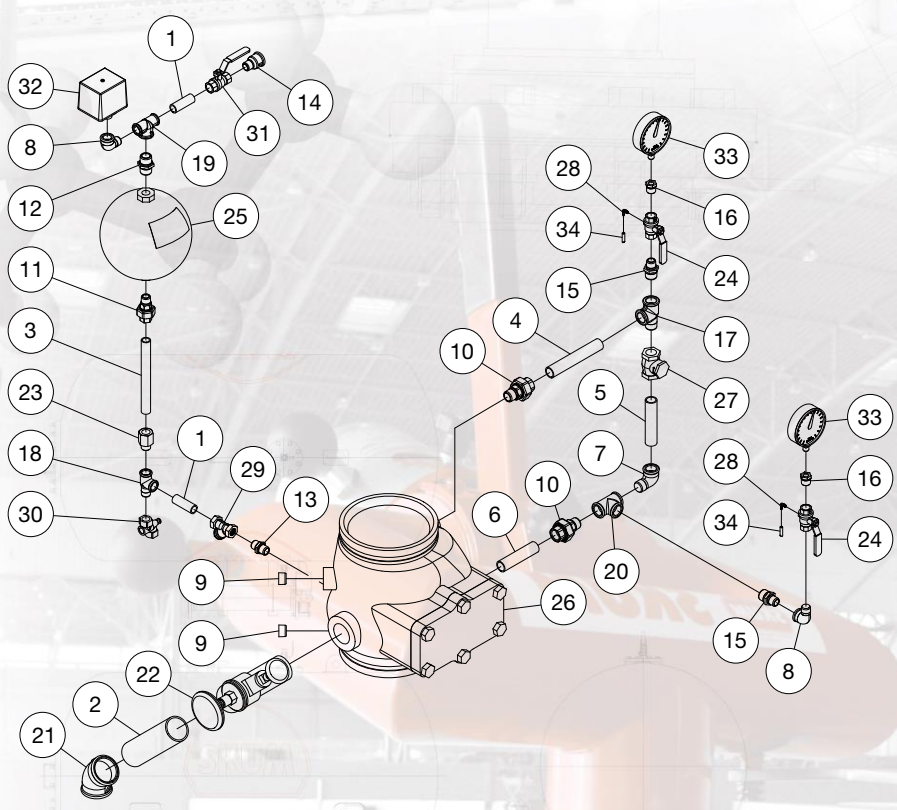
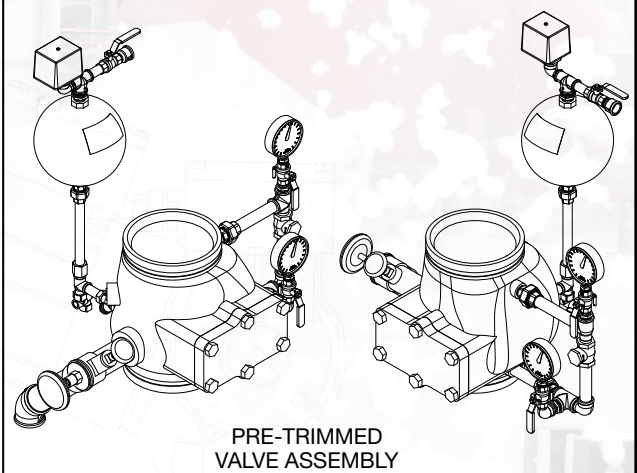
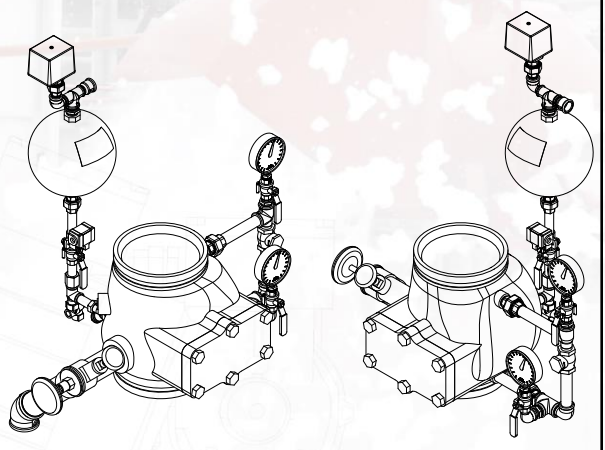

FIGURE 11A
DN200 MODEL AV-1-300 ALARM VALVE
TRIM ARRANGEMENT WITH MODEL RC-1 RETARD CHAMBER

| NO. | DESCRIPTION | QTY. | P/N |
|-----|--|------|----------------|
| 1 | Pressure Relief Hose 3 x 6 x 1,2m Transparent | 1 | WS00000004 |
| 2 | Pipe Nipple, 1/2" x 60mm Galvanized Steel | 2 | AP60D2 |
| 3 | Pipe Nipple, 2" x 200mm Galvanized Steel | 1 | AP200I2 |
| 4 | Pipe Nipple, 3/4" x 160mm Galvanized Steel | 1 | AP160E2 |
| 5 | Pipe Nipple, 3/4" x 120mm Galvanized Steel | 1 | AP120E2 |
| 6 | Pipe Nipple, 1/2" x 120mm Galvanized Steel | 1 | AP120D2 |
| 7 | Pipe Nipple, 3/4" x 110mm Galvanized Steel | 1 | AP110E2 |
| 8 | Elbow 90° M x F 3/4" BSP Galvanized | 1 | A92E2 |
| 9 | Elbow 90° M x F 1/2" BSP Galvanized | 2 | A92D2 |
| 10 | Plug Male 3/4" BSP Galvanized | 2 | A596E2 |
| 11 | Union M x F 3/4" BSP Galvanized | 2 | A341E2 |
| 12 | Union M x F 1/2" BSP Galvanized | 1 | A341D2 |
| 13 | Nipple Male 3/4" BSP Galvanized | 1 | A280E2 |
| 14 | Nipple Male 1/2" BSP Galvanized | 1 | A280D2 |
| 15 | Nipple F x M 3/4" x 1/2" BSP Galvanized | 1 | A246ED2 |
| 16 | Nipple M x F 3/4" x 1/2" BSP Galvanized | 2 | A245ED2 |
| 17 | Nipple M x F 1/2" x 1/4" BSP Galvanized | 2 | A241DB2 |
| 18 | Tee M x F x F 3/4" BSP Galvanized | 1 | A134E2 |
| 19 | Tee M x F x F 1/2" BSP Galvanized | 1 | A134D2 |
| 20 | Reducing Tee Female 1/2" x 3/4" x 1/2" BSP Galvanized | 1 | A130RDED2 |
| 21 | Tee Female 3/4" BSP Galvanized | 1 | A130E2 |
| 22 | Elbow 45° F x F 2" BSP Galvanized | 1 | A120I2 |
| 23 | Test and Drain Valve 2" NPT Inlet x 2" BSP Outlet x 1/2" Test Facility | 1 | 700487 |
| 24 | Nipple M x F 1/2" x 3,56mm Orifice x 45,5mm | 1 | 700484 |
| 25 | Ball Valve DN15-1/2" ISO 7/1 Full Bore PN40 Venthole Threaded M5 | 1 | 59304FO |
| 26 | Retarding Chamber RC-1 | 1 | 522111002 |
| 27 | Alarm Valve Model AV-1-300 8" G x G | 1 | 522031926 |
| 28 | Check Valve, Swing Type, 3/4" | 1 | 460491005 |
| 29 | Elbow WES 3mm x M5 | 1 | 406012 |
| 30 | Strainer 1/2" Bronze | 1 | 305003 |
| 31 | Self-Closing Drain Valve 1/2" Brass | 1 | 2162156 |
| 32 | Pressure Switch Model PS10-1 or TPS10X1 | 1 | 0260 or 100101 |
| 33 | Water Pressure Gauge 300 psi / 21 bar | 2 | 025500013 |
| 34 | Pressure Relief Hose 3 x 6 x 0,6m Transparent | 2 | CH |

Notes
 a. CH: Common Hardware



PRE-TRIMMED
 VALVE ASSEMBLY
 (SHOWN WITH
 SEPARATELY ORDERED
 SUPERVISORY SWITCH)

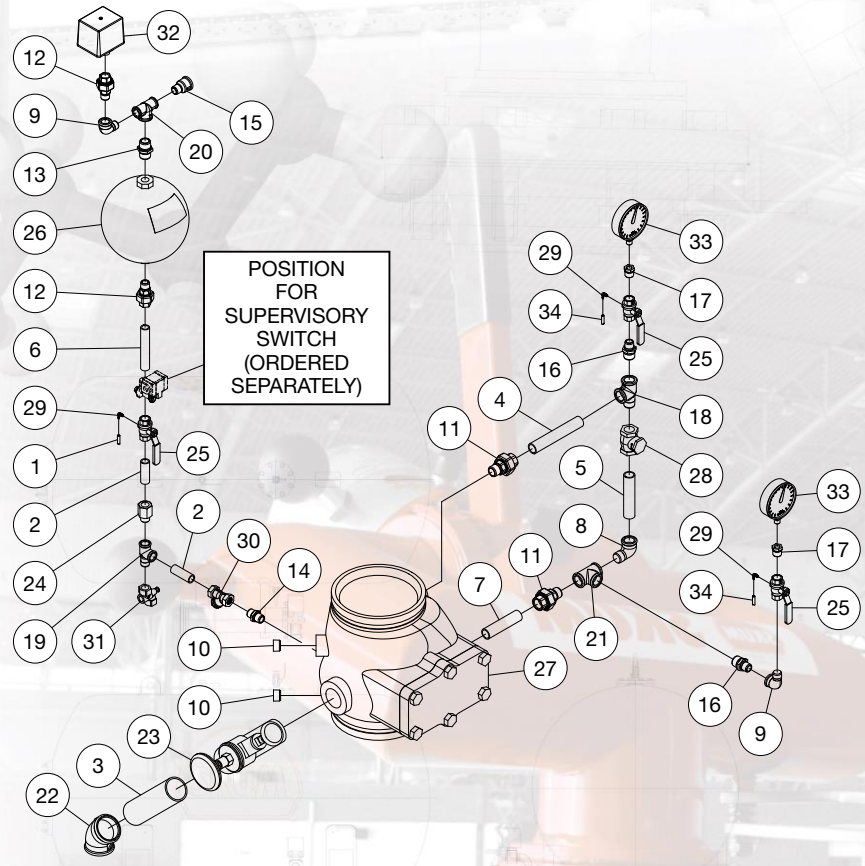
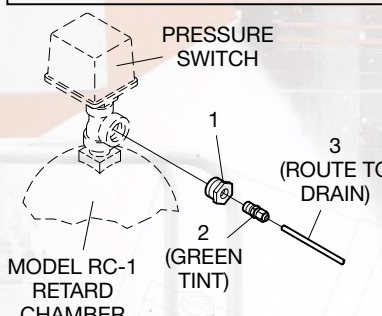

FIGURE 11B
DN200 MODEL AV-1-300 ALARM VALVE
TRIM ARRANGEMENT WITH MODEL RC-1 RETARD CHAMBER
(SUITABLE FOR SUPERVISORY)

| NO. | DESCRIPTION | QTY. | P/N |
|-----|-------------------------|------|--------------|
| 1 | 3/4" x 1/4" Hex Bushing | 1 | CH |
| 2 | 3/32" Vent Fitting | 1 | 92-032-1-002 |
| 3 | 1/4" x 5'-0" Tubing | 1 | CH |



MODEL RC-1 RETARD CHAMBER

Notes

- Trim kit is ordered separately when a Water Motor Alarm (P/N 52-201-2-012) is not installed.
- CH: Common Hardware

FIGURE 12
ALARM VENT TRIM KIT

Valve Setting Procedure

NOTICE

After placing a fire protection system in service, notify the proper authorities and advise those responsible for monitoring proprietary and/or central station alarms.

Filling the system with water will result in operation of the associated alarms. Consequently, notify the owner and the fire department, central station, or other signal station to which the alarms are connected.

The following steps are to be performed when initially setting the TYCO Model AV-1-300 Alarm Check Valve or after system operation due to a fire.

Step 1. Close the Main Control Valve and open the Main Drain Valve, as well as any auxiliary drain valves.

Step 2. Clean the strainers in the alarm line and open the Water Motor Alarm Control Valve.

Step 3. Close the Main Drain Valve, as well as any auxiliary drain valves, and the Alarm Test Valve.

Step 4. Open the remote cross main or branch line vent connection. Refer to Step 6 in the Installation section.

Step 5. Slowly open the main control valve until the sound of flowing water just begins, then open the valve one more turn.

Step 6. Close the remote branch line vent connection after the discharge of aerated water ceases and the outlet has flowed full for at least 15 seconds.

Step 7. Fully open the Main Control Valve.

Step 8. Open the end-of-line Inspector's Test Connection (or Alarm Test Valve, if acceptable to the authority having jurisdiction). Verify that the system alarms operate.

Step 9. Close the end-of-line Inspector's Test Connection (or Alarm Test Valve).

Step 10. Verify that water ceases to flow from the alarm line drain. If water continues to flow, follow the corrective procedure described in the Care and Maintenance section.

Allow sufficient time for drainage of the Retard Chamber and the piping to the water motor alarm. If needed, the plunger on the Automatic Drain Valve can be pressed to accelerate draining of the Retard Chamber.

Step 11. Once it has been verified that the flow of water out of the alarm line drain has stopped, the alarm valve is set and is ready for service.

Care and Maintenance

The following procedures and inspections should be performed as indicated, in addition to any specific requirements of the authority having jurisdiction. Any impairment must be immediately corrected.

Performing the care and maintenance procedures will result in operation of the associated alarms. Consequently, notification must first be given to the owner and fire department, central station, or other signal station to which the alarms are connected.

Before closing a fire protection system main control valve for maintenance work on the fire protection systems that it controls, obtain permission to shut down the affected fire protection systems must first be obtained from the proper authorities, and notify all personnel who may be affected by this action.

The owner is responsible for the inspection, testing, and maintenance of their fire protection system and devices in compliance with this document, as well as in addition to the standards of any authority having jurisdiction. The installing contractor or product manufacturer should be contacted relative to any questions.

Automatic sprinkler systems are recommended to be inspected, tested, and maintained by a qualified Inspection Service.

The Model AV-1-300 Alarm Valves do not require any regularly scheduled maintenance. It is recommended, however, that proper operation of the alarms be periodically verified in accordance with a procedure that is acceptable to the authority having jurisdiction. Any impairment must be immediately corrected.

Periodic Waterflow Alarm Test Procedure

Testing of the system waterflow alarms should be performed periodically based on the requirements of the authority having jurisdiction.

Step 1. Notify the proper authorities and all personnel who may be affected that an alarm test is to be performed.

Step 2. Open the Alarm Test Valve (or end-of-line Inspector's Test Connection, if acceptable to the authority having jurisdiction) and verify that the system alarms operate in accordance with the requirements of the authority having jurisdiction. Verify that the water motor alarm and/or the pressure alarm switch properly actuate and within the elapsed time required by the authority having jurisdiction.

Step 3. Verify that water is draining from the Automatic Drain Valve.

Step 4. Close the Alarm Test Valve (or end-of-line Inspector's Test Connection).

Step 5. Verify that water ceases to flow from the Automatic Drain Valve after allowing sufficient time for the Retard Chamber and alarm line to the water motor alarm, as applicable, to drain.

If desired, the plunger on the Automatic Drain Valve can be pressed to accelerate draining of the Retard Chamber.

Step 6. Clean the Strainer located at the connection to the Retard Chamber, as applicable. Be sure to replace the strainer basket and tighten the cap securely.

NOTICE

Cleaning of the Strainer after each operation of the alarms is especially important in the case of water supplies (such as lakes and rivers) having a large quantity of suspended matter. A clogged alarm line can prevent operation of the alarms.

Step 7. Notify all authorities responsible for monitoring the installation that the fire protection system has been returned to service.

Sprinkler System Drain-Down

Draining the sprinkler system must be done in accordance with the following procedure:

Step 1. Close the main control valve, if this has not already been done.

Step 2. Open the remote cross main or branch line vent connection (Refer to Step 6 in the Installation section).

Step 3. Open the Main Drain Valve. Check first to see that the drainage water discharge will not cause damage or result in dangerous conditions.

Step 4. Wait until the Supply Pressure Gauge reads zero pressure and the sound of draining water has stopped before performing any maintenance work on the fire protection system.

Leakage from Automatic Drain Valve

Follow the steps indicated below until water ceases to flow from the alarm line drain. After each step check if leakage has stopped.

Step 1. Open the Main Drain Valve. Let the water flow for about 5 seconds and then close the Main Drain Valve. This should flush any loose debris that may have become trapped between the Clapper Facing and the Seat Ring or in the seating area of the Drain Valve.

Step 2. Repeat Step 1 if the rate of continued flow out of the drain was noticeably reduced.

Step 3. If leakage from the Automatic Drain Valve does not stop, drain the system in accordance with the prescribed procedure. After the system has been drained, remove the Hand-Hole Cover.

While holding the Spring down by the coils, remove the Hinge Pin. Remove the Spring and Clapper Assembly).

Step 4. Using a light, check for and remove any debris that may have become lodged within the Seat Ring groove. Inspect the Seat Ring seat for any damage. If the Seat Ring has become dented across the seat then the Alarm Check Valve will have to be replaced. It is impractical to re-face a Seat Ring in the field.

Step 5. Check for and remove any debris that may have become lodged in the Clapper Facing. If a minor imperfection remains in the Clapper Facing, then turn it over after thoroughly cleaning both surfaces with a clean cloth. Replace the Clapper Facing if necessary. Be sure to securely re-tighten the retaining fastener for the Clapper Washer.

Step 6. Replace the Spring and Clapper Assembly as shown in Figure 1. While holding the coils of the Spring down, re-insert the Hinge Pin. Be sure that the Hinge Pin is pushed all the way to the rear of the valve.

Step 7. Install the Handhole Cover:

- a. Align the Handhole Cover Gasket and Handhole Cover in proper orientation with the valve body as shown in Figure 1, and hold in place.
- b. Apply LOCTITE No. 242 (or equivalent) to the Hex Bolt threads.
- c. Insert the Hex Bolts through the Handhole Cover Gasket and Handhole Cover, and hand-tighten into the valve body.
- d. Using a crossdraw sequence to assure uniformity, wrench-tighten the Hex Bolts to the appropriate torque values as shown in Table C.
- e. Inspect to assure all the Hex Bolts are securely tightened

Step 8. Return the Alarm Valve to operation in accordance with the steps described in the Setting Procedure section.

Loss of Excess System Pressure

In the case of a variable pressure system, the System Pressure Gauge should normally indicate a pressure greater than that shown by the Supply Pressure Gauge. Also, the value should be close to that of the peak supply pressure that has occurred after the system was placed in service.

NOTICE

Loss of excess system pressure will increase the likelihood of a false alarm in the case of a variable pressure system.

Follow the procedure indicated below to correct a loss of excess system pressure condition.

Step 1. Check for signs of continued leakage from the Automatic Drain Valve. If rust stains and/or water deposits indicate that continued leakage has been taking place, take corrective action according to the procedure described in the sub-section entitled "Leakage From Automatic Drain Valve".

Step 2. If there are no signs of continued leakage from the Automatic Drain Valve, drain the system in accordance with the prescribed procedure and then clean or replace the Bypass Check Valve as required.

| Nominal Valve Sizes in. (DN) | Handhole Cover Bolt Torque lb-ft (N-m) |
|------------------------------|--|
| 2-1/2 (DN65) | 20 (27) |
| 4 (DN100) | 25 (34) |
| 6 (DN150) | 25 (34) |
| 8 (DN200) | 50 (68) |

**TABLE C
HANDHOLE COVER BOLTS
RECOMMENDED TORQUE**

After replacing the Bypass Check Valve as required, return the fire protection system to operation in accordance with the steps described in the Valve Setting Procedure section.

Step 3. If loss of excess system pressure continues, inspect the sprinkler system for leakage.

Excess Pressure Due To Thermal Expansion

Wet pipe sprinkler systems subject to ambient temperatures in excess of 38°C can experience significant increases in system pressure due to the thermal expansion of the water. In particular, a gridded wet-pipe system with a relatively small air pocket and no relief valve can be subjected to an increase of more than 6,9 bar, due to an increase in ambient temperature of approximately 28°C.

As necessary, install a pressure relief valve, in accordance with the requirements of the authority having jurisdiction, to automatically relieve the excess pressure which could otherwise be created in wet-pipe systems that are exposed to significant increases in ambient temperature.

For information on Pressure Release Trim for Alarm Check Valves refer to TFP930.

False Alarms

If repeated false alarms occur in a variable pressure system:

Step 1. Check for and correct the cause of continued leakage out the Automatic Drain Valve.

Step 2. Check for and clean a clogged Self Closing Drain Valve.

Step 3. Check for and correct the cause of a loss in excess system pressure.

Step 4. Drain the sprinkler system and re-fill it in accordance with the steps described in the Valve Setting Procedure section.

| END CONNECTION | | SIZE | | TRIM | | STOP VALVE | | SWITCH | | ACCESSORIES | |
|----------------|------------------------------|------|-------------------|------|-------------------|------------|--------------------------------|--------|----------------------|-------------|---|
| 11 | Groove x Groove | 0 | DN65 76,1 mm* | 88 | EUR Supervised | 00 | To be ordered separately | 0 | None | 00 | None |
| 12 | Flange x Groove ANSI | 4 | DN100 114,3 mm | 89 | EUR | | | 1 | PS10-1 or TPS10X1 | 01 | Model RC-1 Retard Chamber |
| 13 | Flange x Flange ANSI | 6 | DN150 168,3 mm | | | | | | | 03 | None for Supervised Version (88) |
| 14 | Flange x Flange PN10/16 | 7 | DN150 165,1 mm | | | | | | | 05 | Model RC-1 Retard Chamber for Supervised Version (88) |
| 15 | Flange x Flange PN16 (8") | 8 | DN200 219,1 mm | | | | | | | | |
| 16 | Flange x Groove PN16 (8") | | | | | | | | | | |

* Flange x Flange is not available for (76,1 mm)

TABLE D
MODEL AV-1-300 ALARM VALVE
WITH FULLY ASSEMBLED EUROPEAN CONFORMITY TRIM
PART NUMBER SELECTION

Intermittent Alarms

If the pressure alarm switch gives a steady signal, but the water motor generates an intermittent alarm, check for binding in the water motor alarm drive shaft.

If the water motor alarm and/or the pressure alarm switch provide an intermittent alarm, it is likely the consequence of an excessive amount of air being trapped within the sprinkler system. Drain down the sprinkler system and re-fill it in accordance with the steps described in the Valve Setting Procedure section.

A discontinuance of an alarm may also be caused by the Clapper closing due to a sudden drop in supply pressure or the shut-off of a pump in the supply line. These types of problems can only be corrected by maintaining a steady supply pressure.

Limited Warranty

For warranty terms and conditions, visit www.tyco-fire.com.

Ordering Procedure

Contact your local distributor for availability. When placing an order, indicate the full product name and Part Number (P/N).

Model AV-1-300 Alarm Valve with European Conformity Trim

Specify: AV-1-300 Alarm Valve with European Conformity Valve Trim, Fully Assembled, P/N (specify, refer to Table C)

Accessories

Specify: (description) for use with (specify size) Model AV-1-300 Alarm Valve, P/N (specify):

Alarm Vent Trim When Water Motor Alarm Not Installed* 52-201-1-012E

A through Z Labels for Attaching to Valve Components. WS00000033

Waterflow Pressure Alarm Switch PS10-1 or TPS10x1 0260 or 100101

Dual Contact Waterflow Pressure Alarm Switch PS10-2 or TPS10X2 0261 or 100102

Model WMA-1 Water Motor Alarm Red Finish Gong 52-630-1-021R

Supervisory Switch for Water Motor Alarm Control Valve SUPSWITCHB12DN15

* Refer to Figure 12

1467 Elmwood Avenue, Cranston, RI 02910 | Telephone +1-401-781-8220

© 2023 Johnson Controls. All rights reserved. All specifications and other information shown were current as of document revision date and are subject to change without notice.

LOCTITE is a registered trademark of Henkel Corporation



Appendix A of TFP990 AUGUST 2023
Summary Instructions (If problems occur, consult full document)
Wet Alarm Valve, AV-1-300, DN65, Without Retarding Chamber

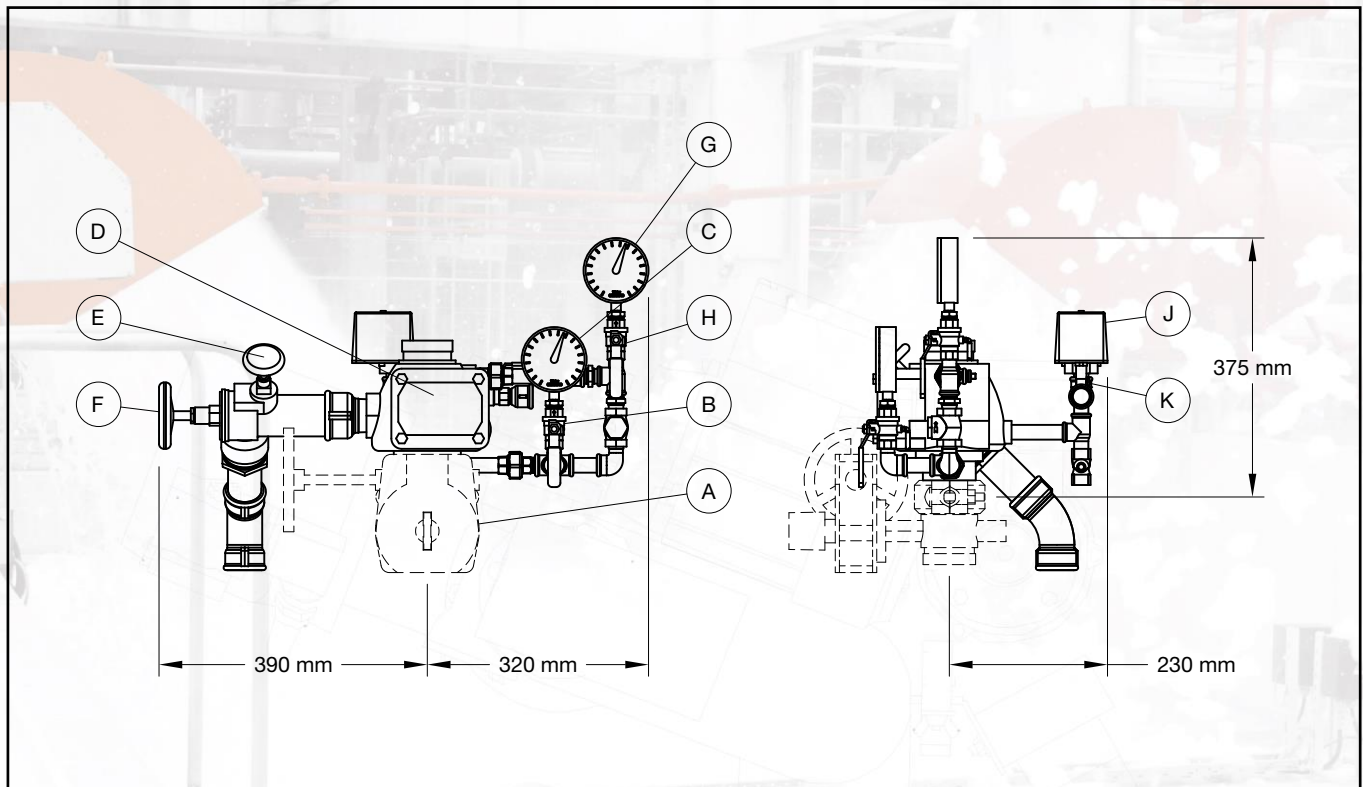

Normal Conditions

- The Main Control Valve (A) is opened and locked.
- The sprinkler system is filled with water and is pressurized.
- The Alarm Test Valve (E) and Main Drain Valve (F) are closed.
- The Water Motor Alarm Control Valve (K) is open.
- The Pressure Gauge Valve (B) is open.
- The Pressure Gauge Valve (H) is open.
- System Pressure Gauge (G) reads downstream pressure.
- Water Supply Pressure Gauge (C) reads upstream pressure.

Operation

When one or more sprinklers are activated, pressure is reduced downstream of the Alarm Valve. This reduction in pressure opens the Clapper in the Alarm Valve and allows water to flow through the alarm port into the alarm line, operating the Waterflow Pressure Alarm Switch (J) and the Water Motor Alarm via the Water Motor Alarm Control Valve (K). The main waterway is now open and water flows into the piping system.

Removing System from Service

Step 1. Close the Main Control Valve (A). Close the Water Motor Alarm Control Valve (K).

Step 2. Drain the system with the Main Drain Valve (F). Open all valves in the system to make sure that cross-mains and branch lines are vented and drained.

Placing the System Back in Service

Step 1. Replace sprinklers that have operated and sprinklers that are close to the fire.

Step 2. Remove the Hand-Hole Cover from the Alarm Check Valve (D). Check and clean the Clapper Facing and Seat Ring.

Step 3. Mount the Hand-Hole Cover.

Step 4. Close Main Drain Valve (F) and other valves in the system.

Step 5. Clean the strainers in the alarm line and the Water Motor Alarm Trim.

Step 6. Open the remote cross-main or branch-line vent connection.

Step 7. Slowly open the Main Control Valve (A) until the sound of flowing water just begins, then open the valve one more turn.

Step 8. Close the remote branch-line vent connection after the discharge of aerated water ceases, and the outlet has flowed fully for at least 15 seconds.

Step 9. Fully open the Main Control Valve (A) and lock it open.

Step 10. Open the Water Motor Alarm Control Valve (K).

Step 11. Reset the fire alarm panel and notify the central alarm station.

Weekly Test

NOTICE

Prior to closing any valves or activating any alarms, notify local security guards and the central alarm station if applicable.

Step 1. Open the Alarm Test Valve (E). Verify that the alarm signal created by the Waterflow Pressure Alarm Switch (J) is visible at the fire panel. If applicable, check the sound of the Water Motor Alarm — it must be clear and steady.

Step 2. Close the Alarm Test Valve (E). Verify that the normal supply and system pressures are restored. If the supply pressure is below normal, use the instructions from the water supply to obtain the usual pressure.

Appendix B of TFP990 AUGUST 2023

Summary Instructions (If problems occur, consult full document)

Wet Alarm Valve, AV-1-300, DN65, Without Retarding Chamber (Suitable for Supervisory)

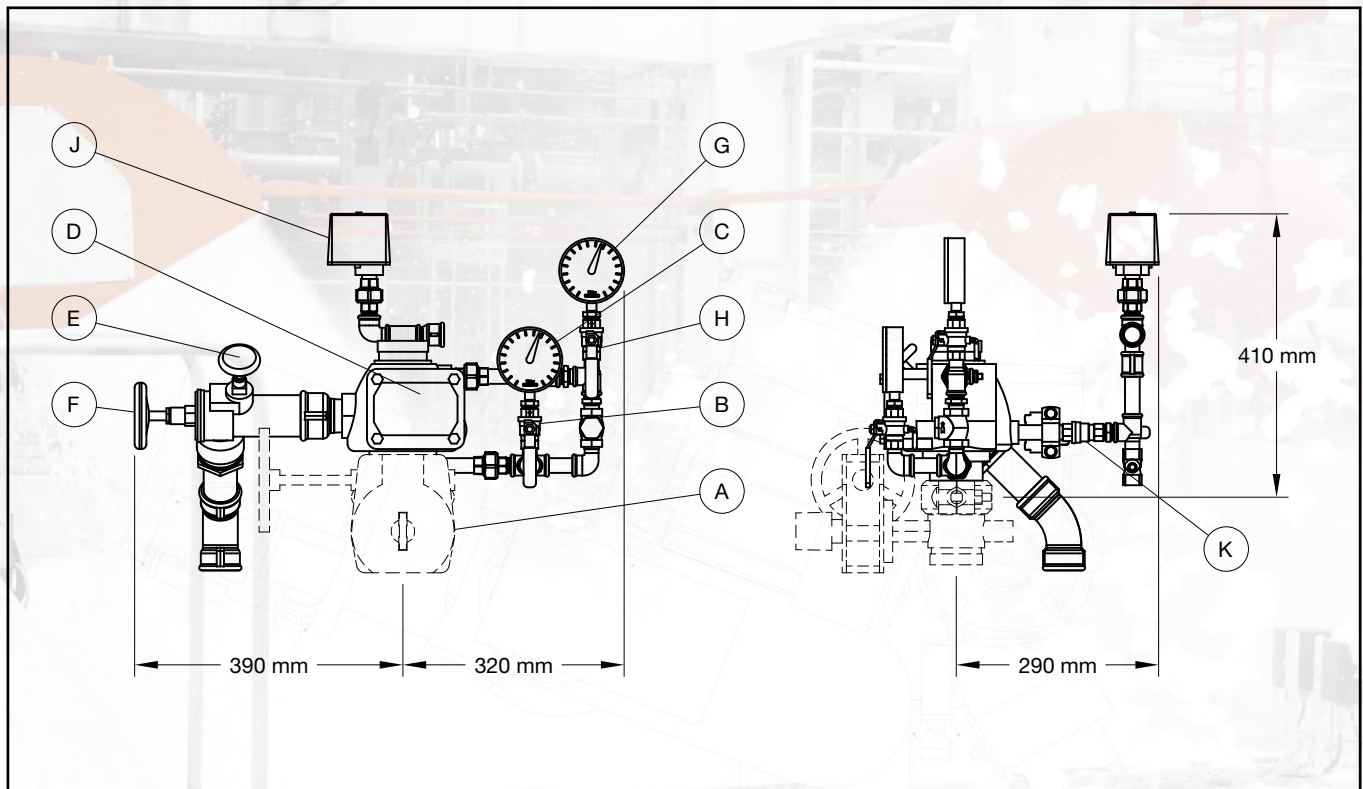

Normal Conditions

- The Main Control Valve (A) is opened and locked.
- The sprinkler system is filled with water and is pressurized.
- The Alarm Test Valve (E) and Main Drain Valve (F) are closed.
- The Water Motor Alarm Control Valve (K) is open.
- The Pressure Gauge Valve (B) is open.
- The Pressure Gauge Valve (H) is open.
- System Pressure Gauge (G) reads downstream pressure.
- Water Supply Pressure Gauge (C) reads upstream pressure.

Operation

When one or more sprinklers are activated, pressure is reduced downstream of the Alarm Valve. This reduction in pressure opens the Clapper in the Alarm Valve and allows water to flow through the alarm port into the alarm line, operating the Waterflow Pressure Alarm Switch (J) and the Water Motor Alarm via the Water Motor Alarm Control Valve (K). The main waterway is now open and water flows into the piping system.

Removing System from Service

Step 1. Close the Main Control Valve (A). Close the Water Motor Alarm Control Valve (K).

Step 2. Drain the system with the Main Drain Valve (F). Open all valves in the system to make sure that cross-mains and branch lines are vented and drained.

Placing the System Back in Service

Step 1. Replace sprinklers that have operated and sprinklers that are close to the fire.

Step 2. Remove the Hand-Hole Cover from the Alarm Check Valve (D). Check and clean the Clapper Facing and Seat Ring.

Step 3. Mount the Hand-Hole Cover.

Step 4. Close Main Drain Valve (F) and other valves in the system.

Step 5. Clean the strainers in the alarm line and the Water Motor Alarm Trim.

Step 6. Open the remote cross-main or branch-line vent connection.

Step 7. Slowly open the Main Control Valve (A) until the sound of flowing water just begins, then open the valve one more turn.

Step 8. Close the remote branch-line vent connection after the discharge of aerated water ceases, and the outlet has flowed fully for at least 15 seconds.

Step 9. Fully open the Main Control Valve (A) and lock it open.

Step 10. Open the Water Motor Alarm Control Valve (K).

Step 11. Reset the fire alarm panel and notify the central alarm station.

Weekly Test

NOTICE

Prior to closing any valves or activating any alarms, notify local security guards and the central alarm station if applicable.

Step 1. Open the Alarm Test Valve (E). Verify that the alarm signal created by the Waterflow Pressure Alarm Switch (J) is visible at the fire panel. If applicable, check the sound of the Water Motor Alarm — it must be clear and steady — and the signal of the supervisory switch.

Step 2. Close the Alarm Test Valve (E). Verify that the normal supply and system pressures are restored. If the supply pressure is below normal, use the instructions from the water supply to obtain the usual pressure.

Appendix C of TFP990 AUGUST 2023
Summary Instructions (If problems occur, consult full document)
Wet Alarm Valve, AV-1-300, DN65, With Retarding Chamber

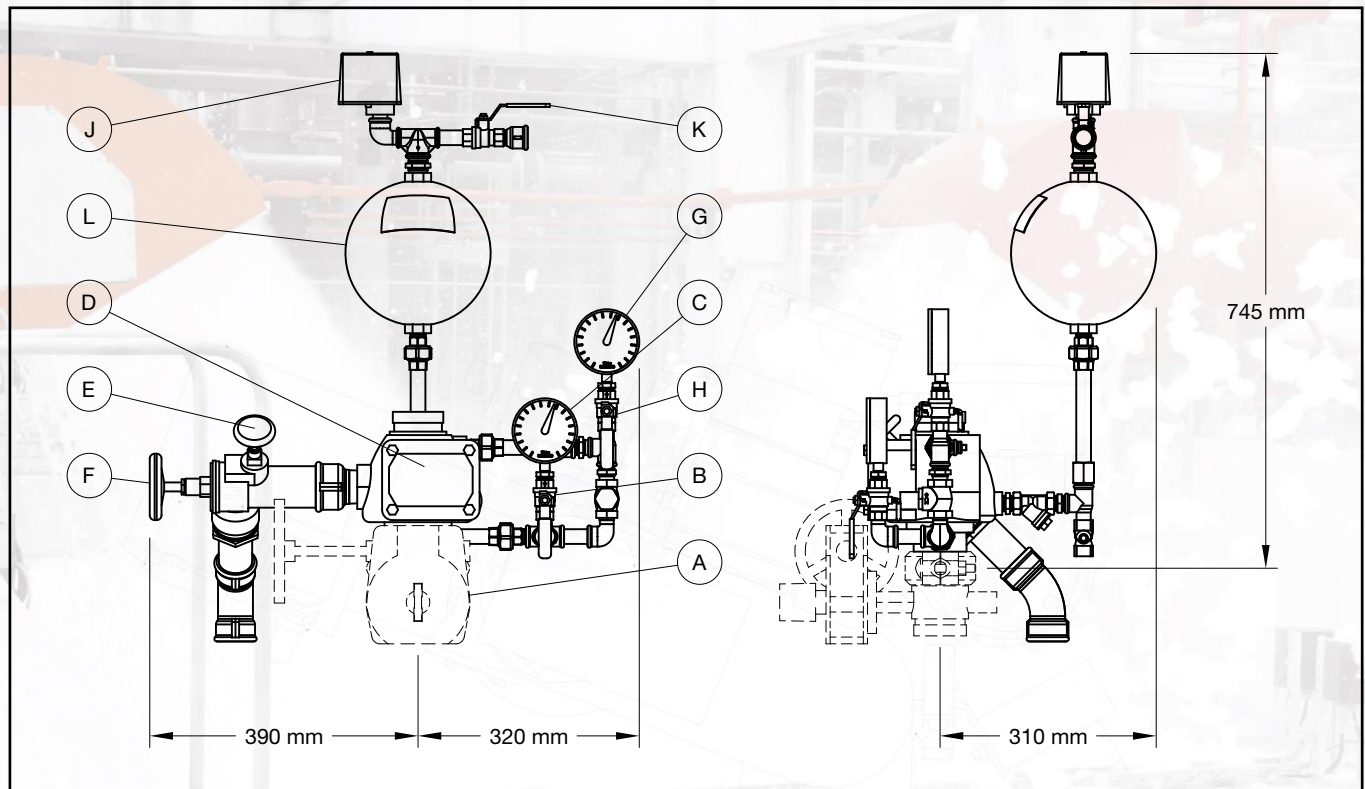

Normal Conditions

- The Main Control Valve (A) is opened and locked.
- The sprinkler system is filled with water and is pressurized.
- The Alarm Test Valve (E) and Main Drain Valve (F) are closed.
- The Water Motor Alarm Control Valve (K) is open.
- The Pressure Gauge Valve (B) is open.
- The Pressure Gauge Valve (H) is open.
- System Pressure Gauge (G) reads downstream pressure.
- Water Supply Pressure Gauge (C) reads upstream pressure.

Operation

When one or more sprinklers are activated, pressure is reduced downstream of the Alarm Valve. This reduction in pressure opens the Clapper in the Alarm Valve and allows water to flow through the alarm port into the alarm line, filling the Model RC-1 Retard Chamber (L) and operating the Waterflow Pressure Alarm Switch (J) and the Water Motor Alarm via the Water Motor Alarm Control Valve (K). The main waterway is now open and water flows into the piping system.

Removing System from Service

Step 1. Close the Main Control Valve (A). Close the Water Motor Alarm Control Valve (K).

Step 2. Drain the system with the Main Drain Valve (F). Open all valves in the system to make sure that cross-mains and branch lines are vented and drained.

Placing the System Back in Service

Step 1. Replace sprinklers that have operated and sprinklers that are close to the fire.

Step 2. Remove the Hand-Hole Cover from the Alarm Check Valve (D). Check and clean the Clapper Facing and Seat Ring.

Step 3. Mount the Hand-Hole Cover.

Step 4. Close Main Drain Valve (F) and other valves in the system.

Step 5. Clean the strainers in the alarm line and the Water Motor Alarm Trim.

Step 6. Open the remote cross-main or branch-line vent connection.

Step 7. Slowly open the Main Control Valve (A) until the sound of flowing water just begins, then open the valve one more turn.

Step 8. Close the remote branch-line vent connection after the discharge of aerated water ceases, and the outlet has flowed fully for at least 15 seconds.

Step 9. Fully open the Main Control Valve (A) and lock it open.

Step 10. Open the Water Motor Alarm Control Valve (K).

Step 11. Reset the fire alarm panel and notify the central alarm station.

Weekly Test

NOTICE

Prior to closing any valves or activating any alarms, notify local security guards and the central alarm station if applicable.

Step 1. Open the Alarm Test Valve (E). Verify that the alarm signal created by the Waterflow Pressure Alarm Switch (J) is visible at the fire panel. If applicable, check the sound of the Water Motor Alarm — it must be clear and steady.

Step 2. Close the Alarm Test Valve (E). Verify that the normal supply and system pressures are restored. If the supply pressure is below normal, use the instructions from the water supply to obtain the usual pressure.

Appendix D of TFP990 AUGUST 2023

Summary Instructions (If problems occur, consult full document)

Wet Alarm Valve, AV-1-300, DN65, With Retarding Chamber (Suitable for Supervisory)

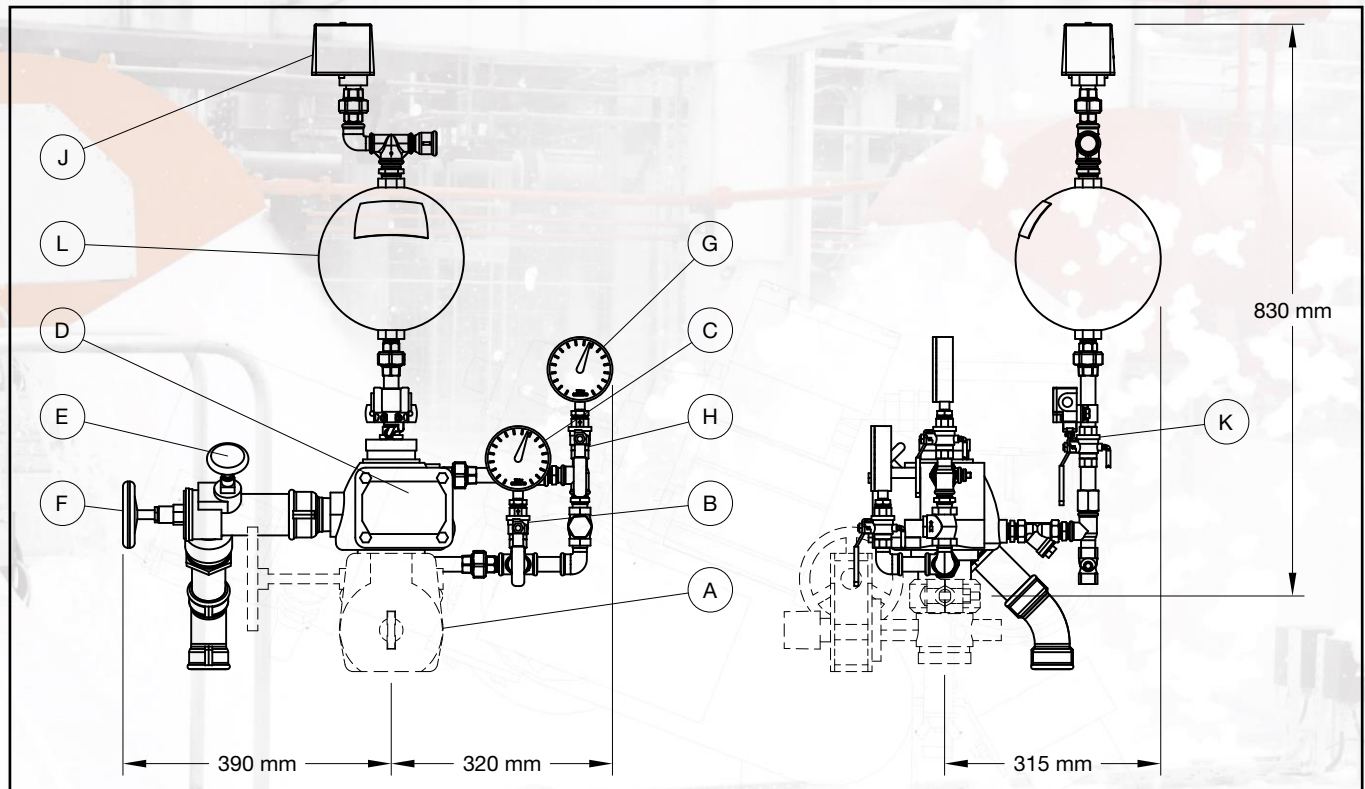

Normal Conditions

- The Main Control Valve (A) is opened and locked.
- The sprinkler system is filled with water and is pressurized.
- The Alarm Test Valve (E) and Main Drain Valve (F) are closed.
- The Water Motor Alarm Control Valve (K) is open.
- The Pressure Gauge Valve (B) is open.
- The Pressure Gauge Valve (H) is open.
- System Pressure Gauge (G) reads downstream pressure.
- Water Supply Pressure Gauge (C) reads upstream pressure.

Operation

When one or more sprinklers are activated, pressure is reduced downstream of the Alarm Valve. This reduction in pressure opens the Clapper in the Alarm Valve and allows water to flow through the alarm port into the alarm line, filling the Model RC-1 Retard Chamber (L) and operating the Waterflow Pressure Alarm Switch (J) and the Water Motor Alarm via the Water Motor Alarm Control Valve (K). The main waterway is now open and water flows into the piping system.

Removing System from Service

Step 1. Close the Main Control Valve (A). Close the Water Motor Alarm Control Valve (K).

Step 2. Drain the system with the Main Drain Valve (F). Open all valves in the system to make sure that cross-mains and branch lines are vented and drained.

Placing the System Back in Service

Step 1. Replace sprinklers that have operated and sprinklers that are close to the fire.

Step 2. Remove the Hand-Hole Cover from the Alarm Check Valve (D). Check and clean the Clapper Facing and Seat Ring.

Step 3. Mount the Hand-Hole Cover.

Step 4. Close Main Drain Valve (F) and other valves in the system.

Step 5. Clean the strainers in the alarm line and the Water Motor Alarm Trim.

Step 6. Open the remote cross-main or branch-line vent connection.

Step 7. Slowly open the Main Control Valve (A) until the sound of flowing water just begins, then open the valve one more turn.

Step 8. Close the remote branch-line vent connection after the discharge of aerated water ceases, and the outlet has flowed fully for at least 15 seconds.

Step 9. Fully open the Main Control Valve (A) and lock it open.

Step 10. Open the Water Motor Alarm Control Valve (K).

Step 11. Reset the fire alarm panel and notify the central alarm station.

Weekly Test

NOTICE

Prior to closing any valves or activating any alarms, notify local security guards and the central alarm station if applicable.

Step 1. Open the Alarm Test Valve (E). Verify that the alarm signal created by the Waterflow Pressure Alarm Switch (J) is visible at the fire panel. If applicable, check the sound of the Water Motor Alarm — it must be clear and steady — and the signal of the supervisory switch.

Step 2. Close the Alarm Test Valve (E). Verify that the normal supply and system pressures are restored. If the supply pressure is below normal, use the instructions from the water supply to obtain the usual pressure.

Appendix E of TFP990 AUGUST 2023

Summary Instructions (If problems occur, consult full document)

Wet Alarm Valve, AV-1-300, DN100, Without Retarding Chamber

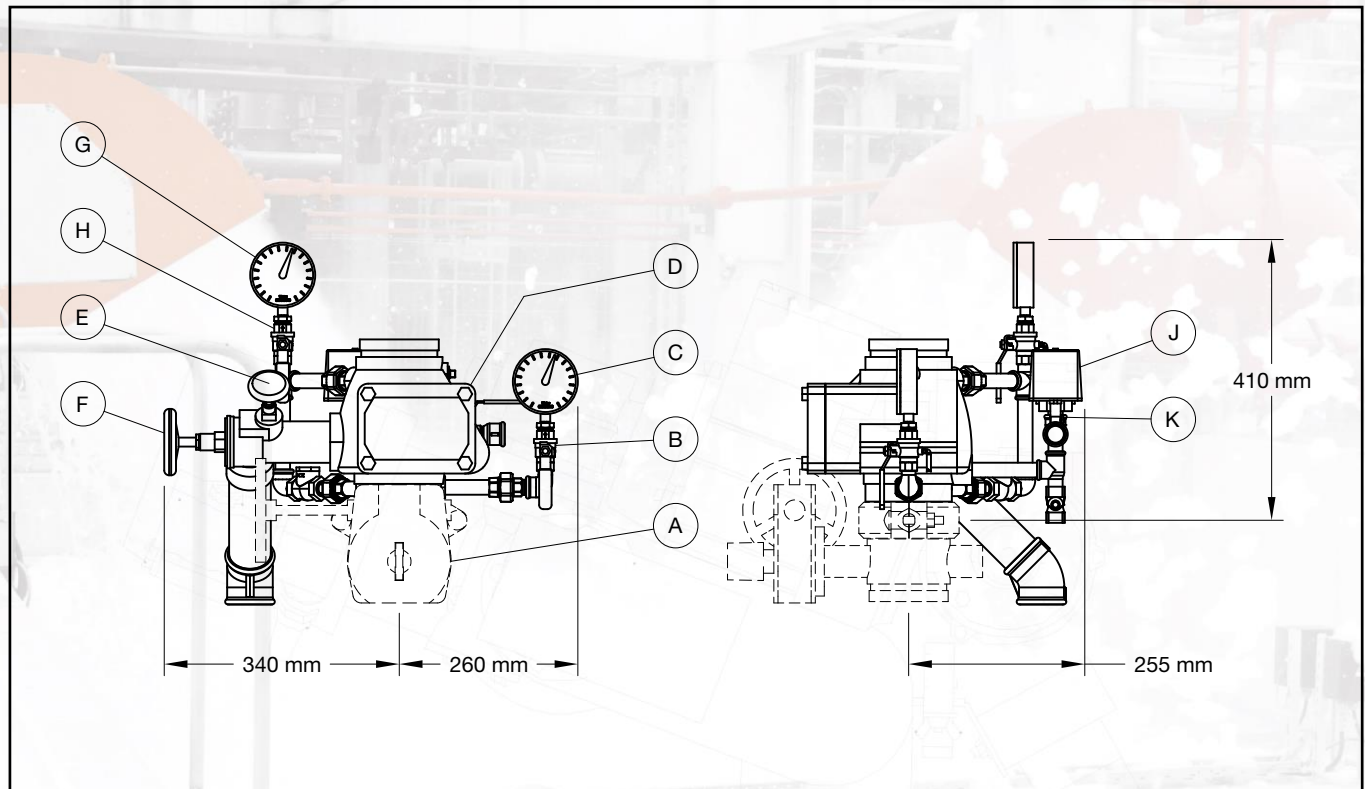

Normal Conditions

- The Main Control Valve (A) is opened and locked.
- The sprinkler system is filled with water and is pressurized.
- The Alarm Test Valve (E) and Main Drain Valve (F) are closed.
- The Water Motor Alarm Control Valve (K) is open.
- The Pressure Gauge Valve (B) is open.
- The Pressure Gauge Valve (H) is open.
- System Pressure Gauge (G) reads downstream pressure.
- Water Supply Pressure Gauge (C) reads upstream pressure.

Operation

When one or more sprinklers are activated, pressure is reduced downstream of the Alarm Valve. This reduction in pressure opens the Clapper in the Alarm Valve and allows water to flow through the alarm port into the alarm line, operating the Waterflow Pressure Alarm Switch (J) and the Water Motor Alarm via the Water Motor Alarm Control Valve (K). The main waterway is now open and water flows into the piping system.

Removing System from Service

Step 1. Close the Main Control Valve (A). Close the Water Motor Alarm Control Valve (K).

Step 2. Drain the system with the Main Drain Valve (F). Open all valves in the system to make sure that cross-mains and branch lines are vented and drained.

Placing the System Back in Service

Step 1. Replace sprinklers that have operated and sprinklers that are close to the fire.

Step 2. Remove the Hand-Hole Cover from the Alarm Check Valve (D). Check and clean the Clapper Facing and Seat Ring.

Step 3. Mount the Hand-Hole Cover.

Step 4. Close Main Drain Valve (F) and other valves in the system.

Step 5. Clean the strainers in the alarm line and the Water Motor Alarm Trim.

Step 6. Open the remote cross-main or branch-line vent connection.

Step 7. Slowly open the Main Control Valve (A) until the sound of flowing water just begins, then open the valve one more turn.

Step 8. Close the remote branch-line vent connection after the discharge of aerated water ceases, and the outlet has flowed fully for at least 15 seconds.

Step 9. Fully open the Main Control Valve (A) and lock it open.

Step 10. Open the Water Motor Alarm Control Valve (K).

Step 11. Reset the fire alarm panel and notify the central alarm station.

Weekly Test

NOTICE

Prior to closing any valves or activating any alarms, notify local security guards and the central alarm station if applicable.

Step 1. Open the Alarm Test Valve (E). Verify that the alarm signal created by the Waterflow Pressure Alarm Switch (J) is visible at the fire panel. If applicable, check the sound of the Water Motor Alarm — it must be clear and steady.

Step 2. Close the Alarm Test Valve (E). Verify that the normal supply and system pressures are restored. If the supply pressure is below normal, use the instructions from the water supply to obtain the usual pressure.

Appendix F of TFP990 AUGUST 2023

Summary Instructions (If problems occur, consult full document)

Wet Alarm Valve, AV-1-300, DN100, Without Retarding Chamber (Suitable for Supervisory)

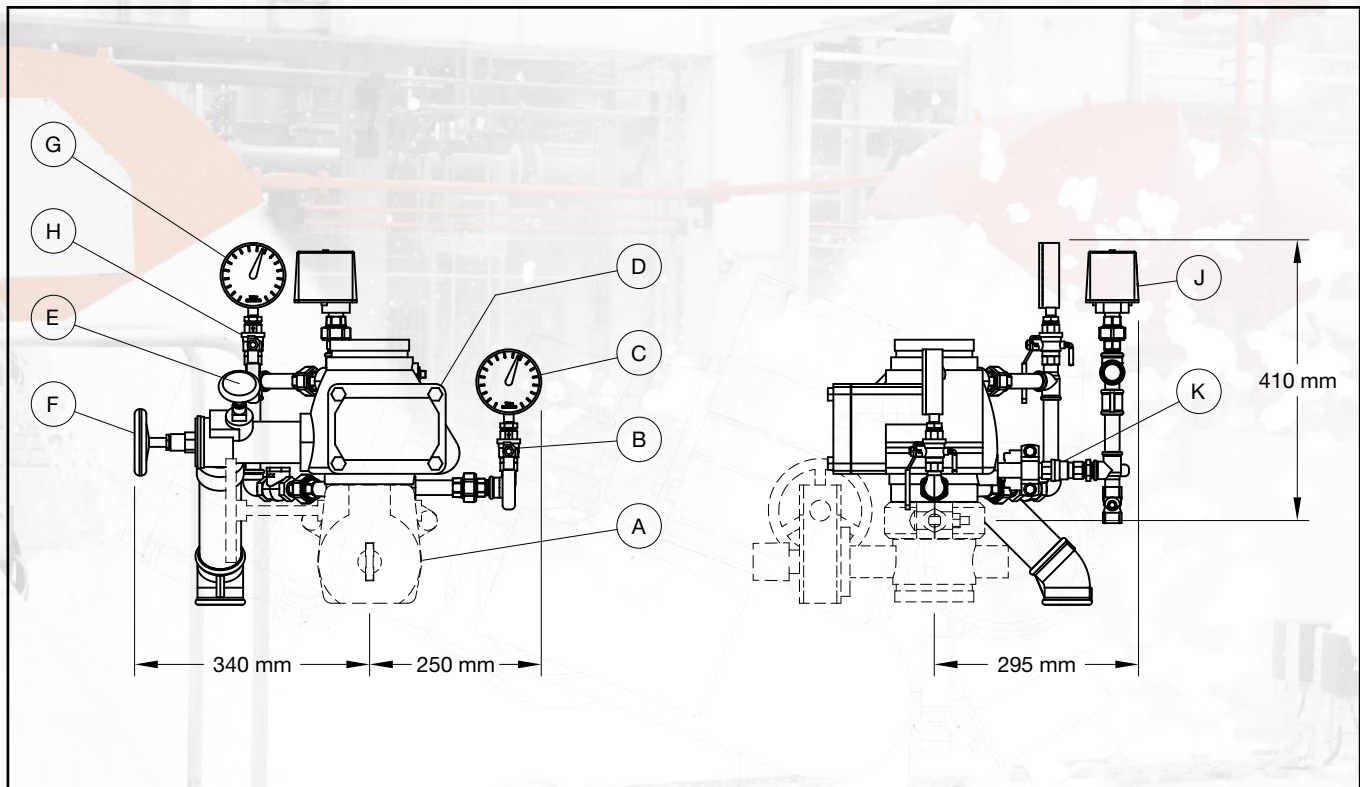

Normal Conditions

- The Main Control Valve (A) is opened and locked.
- The sprinkler system is filled with water and is pressurized.
- The Alarm Test Valve (E) and Main Drain Valve (F) are closed.
- The Water Motor Alarm Control Valve (K) is open.
- The Pressure Gauge Valve (B) is open.
- The Pressure Gauge Valve (H) is open.
- System Pressure Gauge (G) reads downstream pressure.
- Water Supply Pressure Gauge (C) reads upstream pressure.

Operation

When one or more sprinklers are activated, pressure is reduced downstream of the Alarm Valve. This reduction in pressure opens the Clapper in the Alarm Valve and allows water to flow through the alarm port into the alarm line, operating the Waterflow Pressure Alarm Switch (J) and the Water Motor Alarm via the Water Motor Alarm Control Valve (K). The main waterway is now open and water flows into the piping system.

Removing System from Service

Step 1. Close the Main Control Valve (A). Close the Water Motor Alarm Control Valve (K).

Step 2. Drain the system with the Main Drain Valve (F). Open all valves in the system to make sure that cross-mains and branch lines are vented and drained.

Placing the System Back in Service

Step 1. Replace sprinklers that have operated and sprinklers that are close to the fire.

Step 2. Remove the Hand-Hole Cover from the Alarm Check Valve (D). Check and clean the Clapper Facing and Seat Ring.

Step 3. Mount the Hand-Hole Cover.

Step 4. Close Main Drain Valve (F) and other valves in the system.

Step 5. Clean the strainers in the alarm line and the Water Motor Alarm Trim.

Step 6. Open the remote cross-main or branch-line vent connection.

Step 7. Slowly open the Main Control Valve (A) until the sound of flowing water just begins, then open the valve one more turn.

Step 8. Close the remote branch-line vent connection after the discharge of aerated water ceases, and the outlet has flowed fully for at least 15 seconds.

Step 9. Fully open the Main Control Valve (A) and lock it open.

Step 10. Open the Water Motor Alarm Control Valve (K).

Step 11. Reset the fire alarm panel and notify the central alarm station.

Weekly Test

NOTICE

Prior to closing any valves or activating any alarms, notify local security guards and the central alarm station if applicable.

Step 1. Open the Alarm Test Valve (E). Verify that the alarm signal created by the Waterflow Pressure Alarm Switch (J) is visible at the fire panel. If applicable, check the sound of the Water Motor Alarm — it must be clear and steady — and the signal of the supervisory switch.

Step 2. Close the Alarm Test Valve (E). Verify that the normal supply and system pressures are restored. If the supply pressure is below normal, use the instructions from the water supply to obtain the usual pressure.

Appendix G of TFP990 AUGUST 2023
Summary Instructions (If problems occur, consult full document)
Wet Alarm Valve, AV-1-300, DN100, With Retarding Chamber

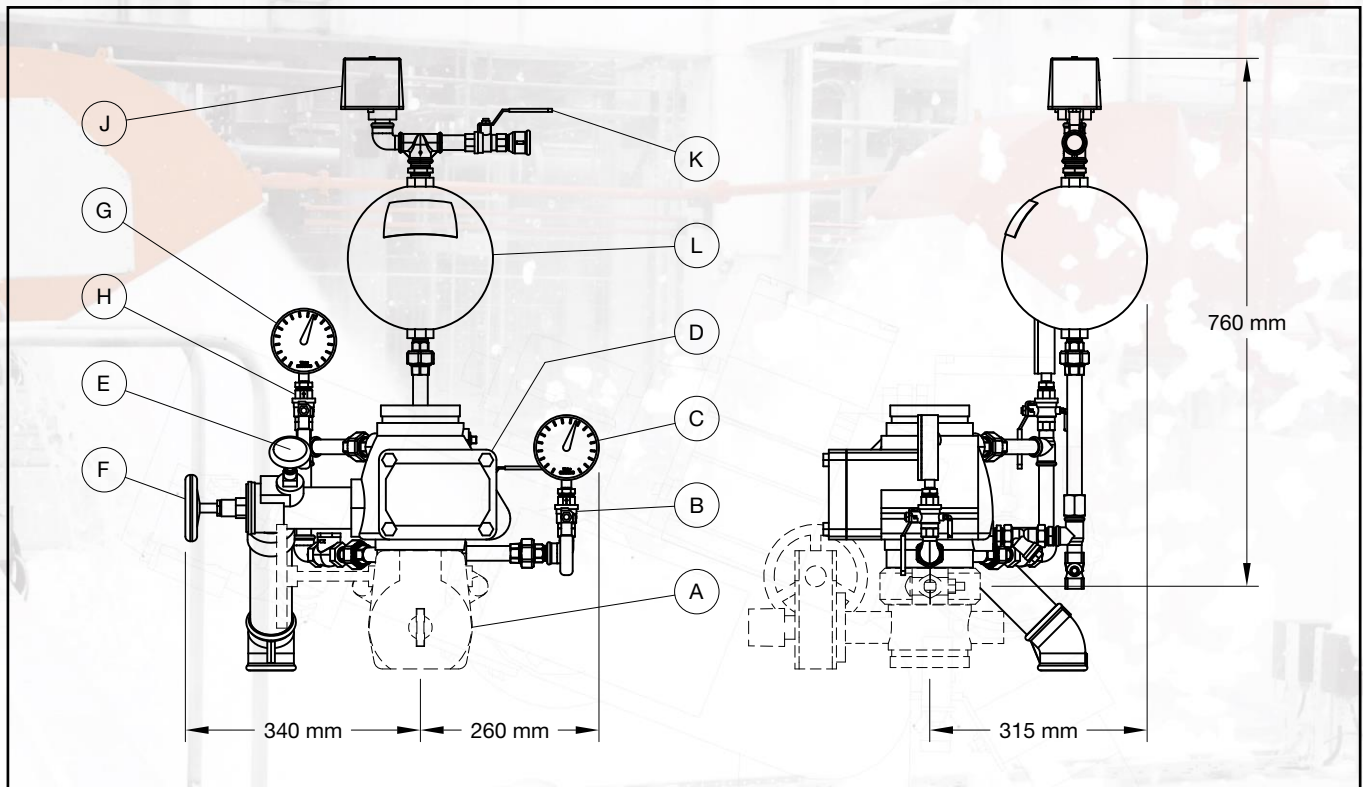

Normal Conditions

- The Main Control Valve (A) is opened and locked.
- The sprinkler system is filled with water and is pressurized.
- The Alarm Test Valve (E) and Main Drain Valve (F) are closed.
- The Water Motor Alarm Control Valve (K) is open.
- The Pressure Gauge Valve (B) is open.
- The Pressure Gauge Valve (H) is open.
- System Pressure Gauge (G) reads downstream pressure.
- Water Supply Pressure Gauge (C) reads upstream pressure.

Operation

When one or more sprinklers are activated, pressure is reduced downstream of the Alarm Valve. This reduction in pressure opens the Clapper in the Alarm Valve and allows water to flow through the alarm port into the alarm line, filling the Model RC-1 Retard Chamber (L) and operating the Waterflow Pressure Alarm Switch (J) and the Water Motor Alarm via the Water Motor Alarm Control Valve (K). The main waterway is now open and water flows into the piping system.

Removing System from Service

Step 1. Close the Main Control Valve (A). Close the Water Motor Alarm Control Valve (K).

Step 2. Drain the system with the Main Drain Valve (F). Open all valves in the system to make sure that cross-mains and branch lines are vented and drained.

Placing the System Back in Service

Step 1. Replace sprinklers that have operated and sprinklers that are close to the fire.

Step 2. Remove the Hand-Hole Cover from the Alarm Check Valve (D). Check and clean the Clapper Facing and Seat Ring.

Step 3. Mount the Hand-Hole Cover.

Step 4. Close Main Drain Valve (F) and other valves in the system.

Step 5. Clean the strainers in the alarm line and the Water Motor Alarm Trim.

Step 6. Open the remote cross-main or branch-line vent connection.

Step 7. Slowly open the Main Control Valve (A) until the sound of flowing water just begins, then open the valve one more turn.

Step 8. Close the remote branch-line vent connection after the discharge of aerated water ceases, and the outlet has flowed fully for at least 15 seconds.

Step 9. Fully open the Main Control Valve (A) and lock it open.

Step 10. Open the Water Motor Alarm Control Valve (K).

Step 11. Reset the fire alarm panel and notify the central alarm station.

Weekly Test

NOTICE

Prior to closing any valves or activating any alarms, notify local security guards and the central alarm station if applicable.

Step 1. Open the Alarm Test Valve (E). Verify that the alarm signal created by the Waterflow Pressure Alarm Switch (J) is visible at the fire panel. If applicable, check the sound of the Water Motor Alarm — it must be clear and steady.

Step 2. Close the Alarm Test Valve (E). Verify that the normal supply and system pressures are restored. If the supply pressure is below normal, use the instructions from the water supply to obtain the usual pressure.

Appendix H of TFP990 AUGUST 2023

Summary Instructions (If problems occur, consult full document)

Wet Alarm Valve, AV-1-300, DN100, With Retarding Chamber (Suitable for Supervisory)

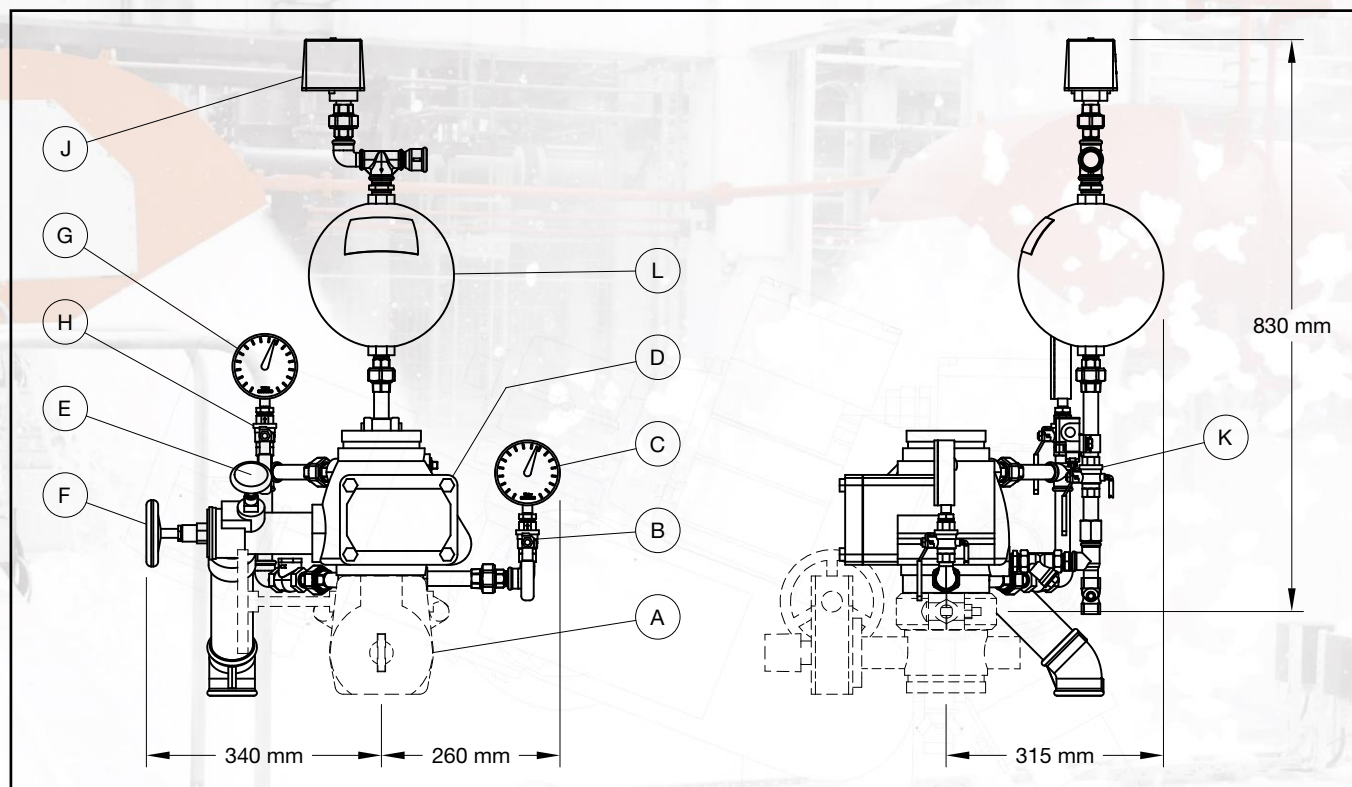

Normal Conditions

- The Main Control Valve (A) is opened and locked.
- The sprinkler system is filled with water and is pressurized.
- The Alarm Test Valve (E) and Main Drain Valve (F) are closed.
- The Water Motor Alarm Control Valve (K) is open.
- The Pressure Gauge Valve (B) is open.
- The Pressure Gauge Valve (H) is open.
- System Pressure Gauge (G) reads downstream pressure.
- Water Supply Pressure Gauge (C) reads upstream pressure.

Operation

When one or more sprinklers are activated, pressure is reduced downstream of the Alarm Valve. This reduction in pressure opens the Clapper in the Alarm Valve and allows water to flow through the alarm port into the alarm line, filling the Model RC-1 Retard Chamber (L) and operating the Waterflow Pressure Alarm Switch (J) and the Water Motor Alarm via the Water Motor Alarm Control Valve (K). The main waterway is now open and water flows into the piping system.

Removing System from Service

Step 1. Close the Main Control Valve (A). Close the Water Motor Alarm Control Valve (K).

Step 2. Drain the system with the Main Drain Valve (F). Open all valves in the system to make sure that cross-mains and branch lines are vented and drained.

Placing the System Back in Service

Step 1. Replace sprinklers that have operated and sprinklers that are close to the fire.

Step 2. Remove the Hand-Hole Cover from the Alarm Check Valve (D). Check and clean the Clapper Facing and Seat Ring.

Step 3. Mount the Hand-Hole Cover.

Step 4. Close Main Drain Valve (F) and other valves in the system.

Step 5. Clean the strainers in the alarm line and the Water Motor Alarm Trim.

Step 6. Open the remote cross-main or branch-line vent connection.

Step 7. Slowly open the Main Control Valve (A) until the sound of flowing water just begins, then open the valve one more turn.

Step 8. Close the remote branch-line vent connection after the discharge of aerated water ceases, and the outlet has flowed fully for at least 15 seconds.

Step 9. Fully open the Main Control Valve (A) and lock it open.

Step 10. Open the Water Motor Alarm Control Valve (K).

Step 11. Reset the fire alarm panel and notify the central alarm station.

Weekly Test

NOTICE

Prior to closing any valves or activating any alarms, notify local security guards and the central alarm station if applicable.

Step 1. Open the Alarm Test Valve (E). Verify that the alarm signal created by the Waterflow Pressure Alarm Switch (J) is visible at the fire panel. If applicable, check the sound of the Water Motor Alarm — it must be clear and steady — and the signal of the supervisory switch.

Step 2. Close the Alarm Test Valve (E). Verify that the normal supply and system pressures are restored. If the supply pressure is below normal, use the instructions from the water supply to obtain the usual pressure.

Appendix J of TFP990 AUGUST 2023
Summary Instructions (If problems occur, consult full document)
Wet Alarm Valve, AV-1-300, DN150, Without Retarding Chamber

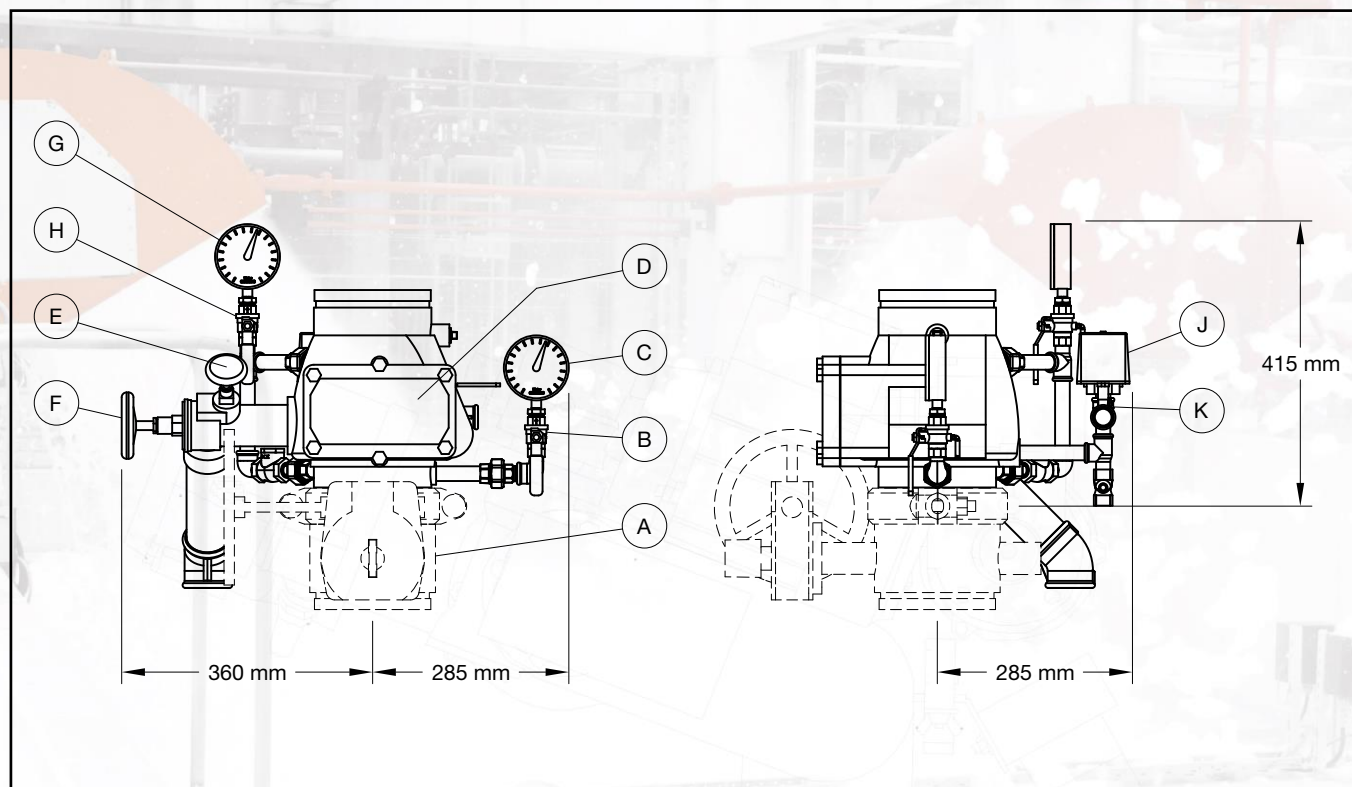

Normal Conditions

- The Main Control Valve (A) is opened and locked.
- The sprinkler system is filled with water and is pressurized.
- The Alarm Test Valve (E) and Main Drain Valve (F) are closed.
- The Water Motor Alarm Control Valve (K) is open.
- The Pressure Gauge Valve (B) is open.
- The Pressure Gauge Valve (H) is open.
- System Pressure Gauge (G) reads downstream pressure.
- Water Supply Pressure Gauge (C) reads upstream pressure.

Operation

When one or more sprinklers are activated, pressure is reduced downstream of the Alarm Valve. This reduction in pressure opens the Clapper in the Alarm Valve and allows water to flow through the alarm port into the alarm line, operating the Waterflow Pressure Alarm Switch (J) and the Water Motor Alarm via the Water Motor Alarm Control Valve (K). The main waterway is now open and water flows into the piping system.

Removing System from Service

Step 1. Close the Main Control Valve (A). Close the Water Motor Alarm Control Valve (K).

Step 2. Drain the system with the Main Drain Valve (F). Open all valves in the system to make sure that cross-mains and branch lines are vented and drained.

Placing the System Back in Service

Step 1. Replace sprinklers that have operated and sprinklers that are close to the fire.

Step 2. Remove the Hand-Hole Cover from the Alarm Check Valve (D). Check and clean the Clapper Facing and Seat Ring.

Step 3. Mount the Hand-Hole Cover.

Step 4. Close Main Drain Valve (F) and other valves in the system.

Step 5. Clean the strainers in the alarm line and the Water Motor Alarm Trim.

Step 6. Open the remote cross-main or branch-line vent connection.

Step 7. Slowly open the Main Control Valve (A) until the sound of flowing water just begins, then open the valve one more turn.

Step 8. Close the remote branch-line vent connection after the discharge of aerated water ceases, and the outlet has flowed fully for at least 15 seconds.

Step 9. Fully open the Main Control Valve (A) and lock it open.

Step 10. Open the Water Motor Alarm Control Valve (K).

Step 11. Reset the fire alarm panel and notify the central alarm station.

Weekly Test

NOTICE

Prior to closing any valves or activating any alarms, notify local security guards and the central alarm station if applicable.

Step 1. Open the Alarm Test Valve (E). Verify that the alarm signal created by the Waterflow Pressure Alarm Switch (J) is visible at the fire panel. If applicable, check the sound of the Water Motor Alarm — it must be clear and steady.

Step 2. Close the Alarm Test Valve (E). Verify that the normal supply and system pressures are restored. If the supply pressure is below normal, use the instructions from the water supply to obtain the usual pressure.

Appendix K of TFP990 AUGUST 2023

Summary Instructions (If problems occur, consult full document)

Wet Alarm Valve, AV-1-300, DN150, Without Retarding Chamber (Suitable for Supervisory)

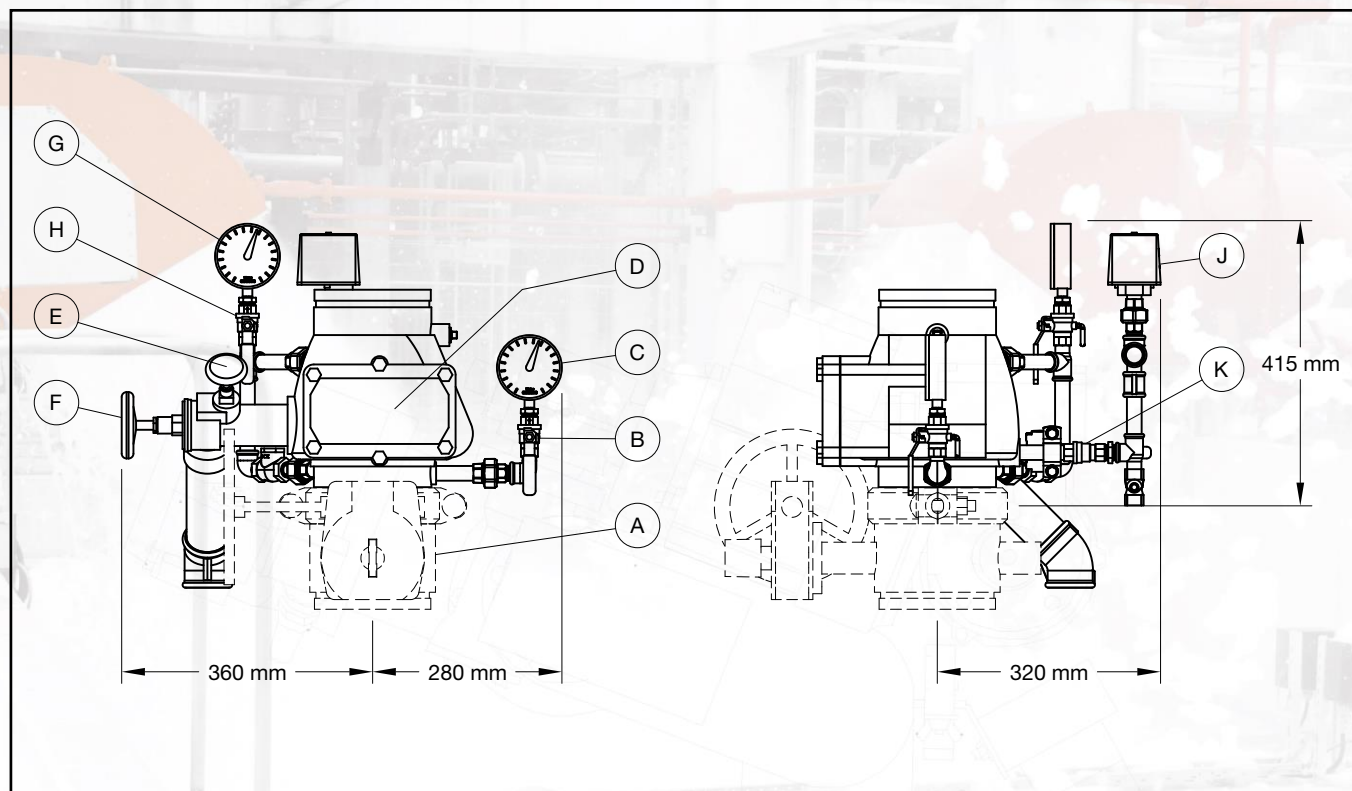

Normal Conditions

- The Main Control Valve (A) is opened and locked.
- The sprinkler system is filled with water and is pressurized.
- The Alarm Test Valve (E) and Main Drain Valve (F) are closed.
- The Water Motor Alarm Control Valve (K) is open.
- The Pressure Gauge Valve (B) is open.
- The Pressure Gauge Valve (H) is open.
- System Pressure Gauge (G) reads downstream pressure.
- Water Supply Pressure Gauge (C) reads upstream pressure.

Operation

When one or more sprinklers are activated, pressure is reduced downstream of the Alarm Valve. This reduction in pressure opens the Clapper in the Alarm Valve and allows water to flow through the alarm port into the alarm line, operating the Waterflow Pressure Alarm Switch (J) and the Water Motor Alarm via the Water Motor Alarm Control Valve (K). The main waterway is now open and water flows into the piping system.

Removing System from Service

Step 1. Close the Main Control Valve (A). Close the Water Motor Alarm Control Valve (K).

Step 2. Drain the system with the Main Drain Valve (F). Open all valves in the system to make sure that cross-mains and branch lines are vented and drained.

Placing the System Back in Service

Step 1. Replace sprinklers that have operated and sprinklers that are close to the fire.

Step 2. Remove the Hand-Hole Cover from the Alarm Check Valve (D). Check and clean the Clapper Facing and Seat Ring.

Step 3. Mount the Hand-Hole Cover.

Step 4. Close Main Drain Valve (F) and other valves in the system.

Step 5. Clean the strainers in the alarm line and the Water Motor Alarm Trim.

Step 6. Open the remote cross-main or branch-line vent connection.

Step 7. Slowly open the Main Control Valve (A) until the sound of flowing water just begins, then open the valve one more turn.

Step 8. Close the remote branch-line vent connection after the discharge of aerated water ceases, and the outlet has flowed fully for at least 15 seconds.

Step 9. Fully open the Main Control Valve (A) and lock it open.

Step 10. Open the Water Motor Alarm Control Valve (K).

Step 11. Reset the fire alarm panel and notify the central alarm station.

Weekly Test

NOTICE

Prior to closing any valves or activating any alarms, notify local security guards and the central alarm station if applicable.

Step 1. Open the Alarm Test Valve (E). Verify that the alarm signal created by the Waterflow Pressure Alarm Switch (J) is visible at the fire panel. If applicable, check the sound of the Water Motor Alarm — it must be clear and steady — and the signal of the supervisory switch.

Step 2. Close the Alarm Test Valve (E). Verify that the normal supply and system pressures are restored. If the supply pressure is below normal, use the instructions from the water supply to obtain the usual pressure.

Appendix L of TFP990 AUGUST 2023
Summary Instructions (If problems occur, consult full document)
Wet Alarm Valve, AV-1-300, DN150, With Retarding Chamber

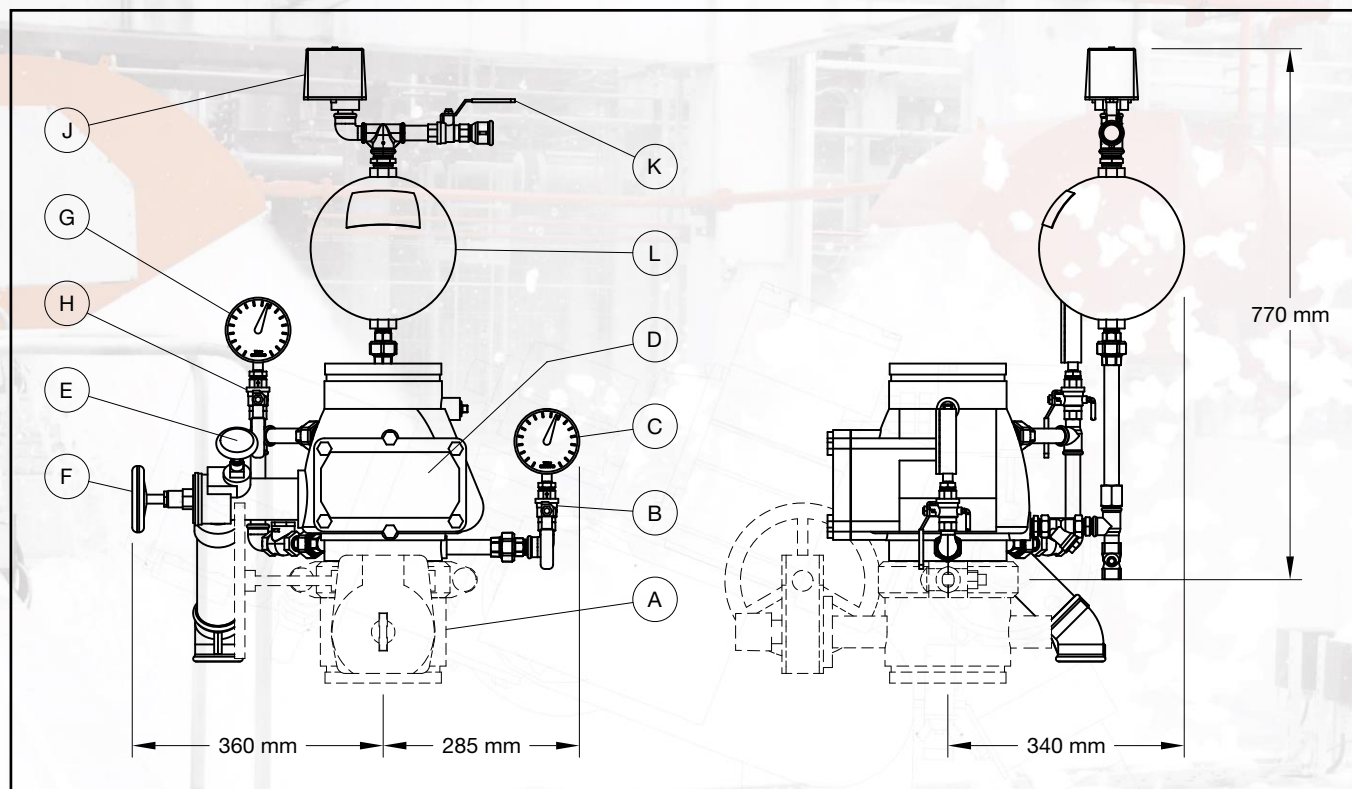

Normal Conditions

- The Main Control Valve (A) is opened and locked.
- The sprinkler system is filled with water and is pressurized.
- The Alarm Test Valve (E) and Main Drain Valve (F) are closed.
- The Water Motor Alarm Control Valve (K) is open.
- The Pressure Gauge Valve (B) is open.
- The Pressure Gauge Valve (H) is open.
- System Pressure Gauge (G) reads downstream pressure.
- Water Supply Pressure Gauge (C) reads upstream pressure.

Operation

When one or more sprinklers are activated, pressure is reduced downstream of the Alarm Valve. This reduction in pressure opens the Clapper in the Alarm Valve and allows water to flow through the alarm port into the alarm line, filling the Model RC-1 Retard Chamber (L) and operating the Waterflow Pressure Alarm Switch (J) and the Water Motor Alarm via the Water Motor Alarm Control Valve (K). The main waterway is now open and water flows into the piping system.

Removing System from Service

Step 1. Close the Main Control Valve (A). Close the Water Motor Alarm Control Valve (K).

Step 2. Drain the system with the Main Drain Valve (F). Open all valves in the system to make sure that cross-mains and branch lines are vented and drained.

Placing the System Back in Service

Step 1. Replace sprinklers that have operated and sprinklers that are close to the fire.

Step 2. Remove the Hand-Hole Cover from the Alarm Check Valve (D). Check and clean the Clapper Facing and Seat Ring.

Step 3. Mount the Hand-Hole Cover.

Step 4. Close Main Drain Valve (F) and other valves in the system.

Step 5. Clean the strainers in the alarm line and the Water Motor Alarm Trim.

Step 6. Open the remote cross-main or branch-line vent connection.

Step 7. Slowly open the Main Control Valve (A) until the sound of flowing water just begins, then open the valve one more turn.

Step 8. Close the remote branch-line vent connection after the discharge of aerated water ceases, and the outlet has flowed fully for at least 15 seconds.

Step 9. Fully open the Main Control Valve (A) and lock it open.

Step 10. Open the Water Motor Alarm Control Valve (K).

Step 11. Reset the fire alarm panel and notify the central alarm station.

Weekly Test

NOTICE

Prior to closing any valves or activating any alarms, notify local security guards and the central alarm station if applicable.

Step 1. Open the Alarm Test Valve (E). Verify that the alarm signal created by the Waterflow Pressure Alarm Switch (J) is visible at the fire panel. If applicable, check the sound of the Water Motor Alarm — it must be clear and steady.

Step 2. Close the Alarm Test Valve (E). Verify that the normal supply and system pressures are restored. If the supply pressure is below normal, use the instructions from the water supply to obtain the usual pressure.

Appendix M of TFP990 AUGUST 2023
Summary Instructions (If problems occur, consult full document)
Wet Alarm Valve, AV-1-300, DN150, With Retarding Chamber (Suitable for Supervisory)

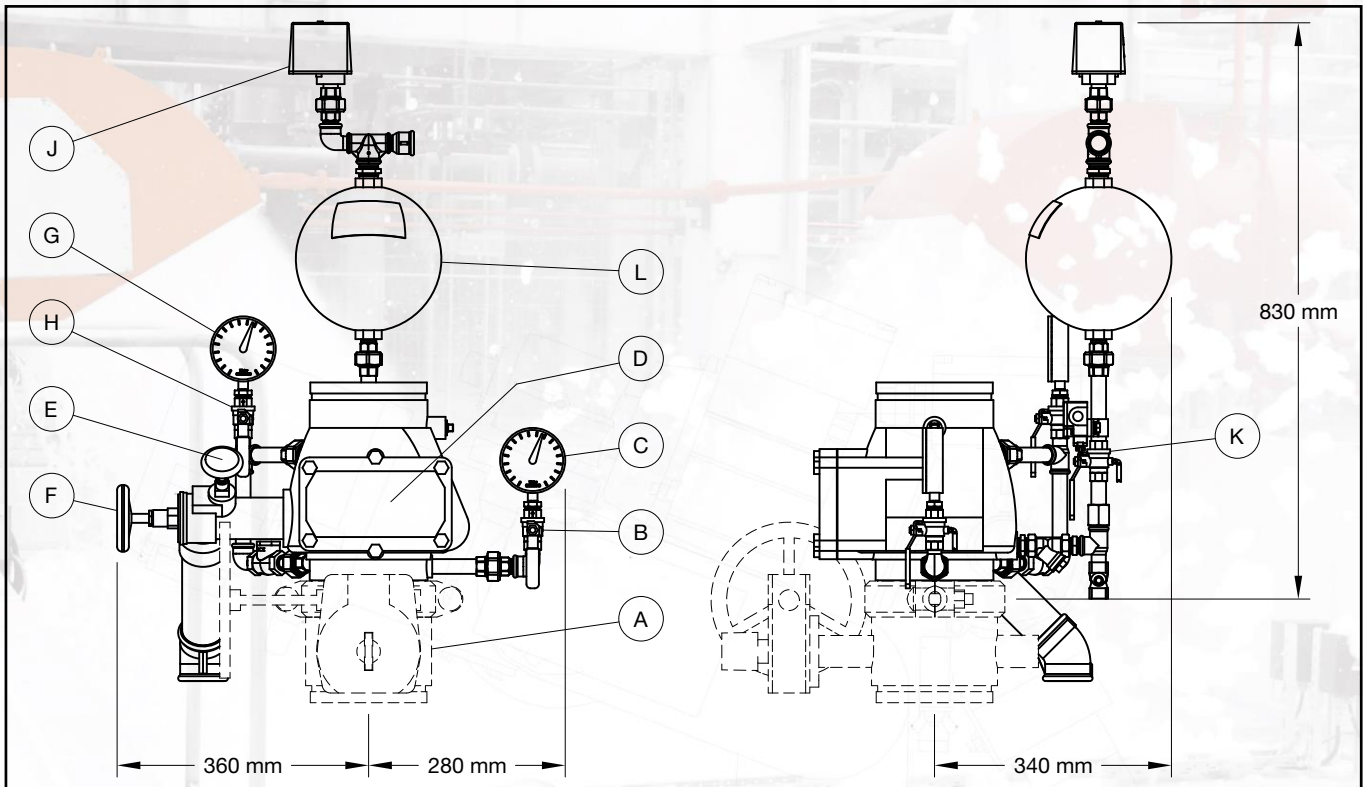

Normal Conditions

- The Main Control Valve (A) is opened and locked.
- The sprinkler system is filled with water and is pressurized.
- The Alarm Test Valve (E) and Main Drain Valve (F) are closed.
- The Water Motor Alarm Control Valve (K) is open.
- The Pressure Gauge Valve (B) is open.
- The Pressure Gauge Valve (H) is open.
- System Pressure Gauge (G) reads downstream pressure.
- Water Supply Pressure Gauge (C) reads upstream pressure.

Operation

When one or more sprinklers are activated, pressure is reduced downstream of the Alarm Valve. This reduction in pressure opens the Clapper in the Alarm Valve and allows water to flow through the alarm port into the alarm line, filling the Model RC-1 Retard Chamber (L) and operating the Waterflow Pressure Alarm Switch (J) and the Water Motor Alarm via the Water Motor Alarm Control Valve (K). The main waterway is now open and water flows into the piping system.

Removing System from Service

Step 1. Close the Main Control Valve (A). Close the Water Motor Alarm Control Valve (K).

Step 2. Drain the system with the Main Drain Valve (F). Open all valves in the system to make sure that cross-mains and branch lines are vented and drained.

Placing the System Back in Service

Step 1. Replace sprinklers that have operated and sprinklers that are close to the fire.

Step 2. Remove the Hand-Hole Cover from the Alarm Check Valve (D). Check and clean the Clapper Facing and Seat Ring.

Step 3. Mount the Hand-Hole Cover.

Step 4. Close Main Drain Valve (F) and other valves in the system.

Step 5. Clean the strainers in the alarm line and the Water Motor Alarm Trim.

Step 6. Open the remote cross-main or branch-line vent connection.

Step 7. Slowly open the Main Control Valve (A) until the sound of flowing water just begins, then open the valve one more turn.

Step 8. Close the remote branch-line vent connection after the discharge of aerated water ceases, and the outlet has flowed fully for at least 15 seconds.

Step 9. Fully open the Main Control Valve (A) and lock it open.

Step 10. Open the Water Motor Alarm Control Valve (K).

Step 11. Reset the fire alarm panel and notify the central alarm station.

Weekly Test

NOTICE

Prior to closing any valves or activating any alarms, notify local security guards and the central alarm station if applicable.

Step 1. Open the Alarm Test Valve (E). Verify that the alarm signal created by the Waterflow Pressure Alarm Switch (J) is visible at the fire panel. If applicable, check the sound of the Water Motor Alarm — it must be clear and steady — and the signal of the supervisory switch.

Step 2. Close the Alarm Test Valve (E). Verify that the normal supply and system pressures are restored. If the supply pressure is below normal, use the instructions from the water supply to obtain the usual pressure.

Appendix N of TFP990 AUGUST 2023
Summary Instructions (If problems occur, consult full document)
Wet Alarm Valve, AV-1-300, DN200, Without Retarding Chamber

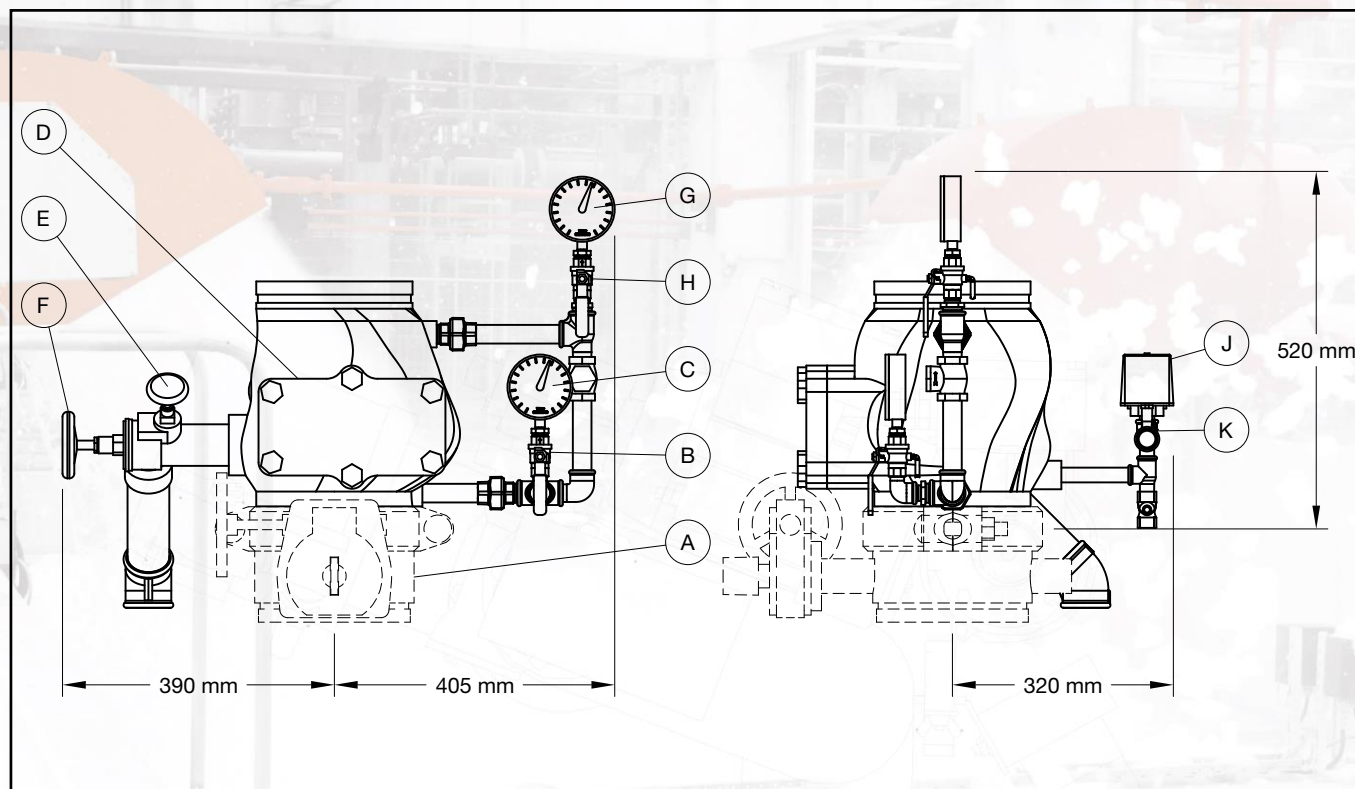

Normal Conditions

- The Main Control Valve (A) is opened and locked.
- The sprinkler system is filled with water and is pressurized.
- The Alarm Test Valve (E) and Main Drain Valve (F) are closed.
- The Water Motor Alarm Control Valve (K) is open.
- The Pressure Gauge Valve (B) is open.
- The Pressure Gauge Valve (H) is open.
- System Pressure Gauge (G) reads downstream pressure.
- Water Supply Pressure Gauge (C) reads upstream pressure.

Operation

When one or more sprinklers are activated, pressure is reduced downstream of the Alarm Valve. This reduction in pressure opens the Clapper in the Alarm Valve and allows water to flow through the alarm port into the alarm line, operating the Waterflow Pressure Alarm Switch (J) and the Water Motor Alarm via the Water Motor Alarm Control Valve (K). The main waterway is now open and water flows into the piping system.

Removing System from Service

Step 1. Close the Main Control Valve (A). Close the Water Motor Alarm Control Valve (K).

Step 2. Drain the system with the Main Drain Valve (F). Open all valves in the system to make sure that cross-mains and branch lines are vented and drained.

Placing the System Back in Service

Step 1. Replace sprinklers that have operated and sprinklers that are close to the fire.

Step 2. Remove the Hand-Hole Cover from the Alarm Check Valve (D). Check and clean the Clapper Facing and Seat Ring.

Step 3. Mount the Hand-Hole Cover.

Step 4. Close Main Drain Valve (F) and other valves in the system.

Step 5. Clean the strainers in the alarm line and the Water Motor Alarm Trim.

Step 6. Open the remote cross-main or branch-line vent connection.

Step 7. Slowly open the Main Control Valve (A) until the sound of flowing water just begins, then open the valve one more turn.

Step 8. Close the remote branch-line vent connection after the discharge of aerated water ceases, and the outlet has flowed fully for at least 15 seconds.

Step 9. Fully open the Main Control Valve (A) and lock it open.

Step 10. Open the Water Motor Alarm Control Valve (K).

Step 11. Reset the fire alarm panel and notify the central alarm station.

Weekly Test

NOTICE

Prior to closing any valves or activating any alarms, notify local security guards and the central alarm station if applicable.

Step 1. Open the Alarm Test Valve (E). Verify that the alarm signal created by the Waterflow Pressure Alarm Switch (J) is visible at the fire panel. If applicable, check the sound of the Water Motor Alarm — it must be clear and steady.

Step 2. Close the Alarm Test Valve (E). Verify that the normal supply and system pressures are restored. If the supply pressure is below normal, use the instructions from the water supply to obtain the usual pressure.

Appendix P of TFP990 AUGUST 2023

Summary Instructions (If problems occur, consult full document)

Wet Alarm Valve, AV-1-300, DN200, Without Retarding Chamber (Suitable for Supervisory)

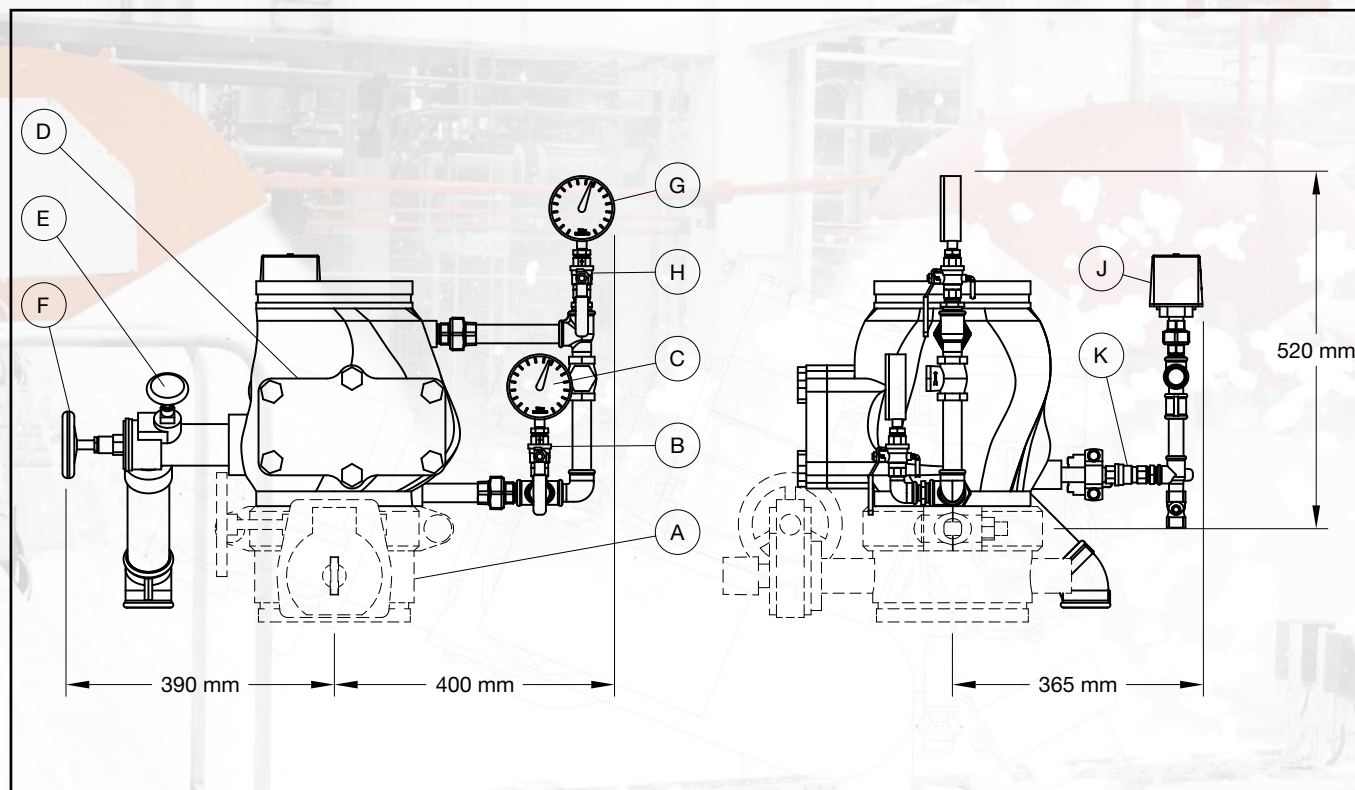

Normal Conditions

- The Main Control Valve (A) is opened and locked.
- The sprinkler system is filled with water and is pressurized.
- The Alarm Test Valve (E) and Main Drain Valve (F) are closed.
- The Water Motor Alarm Control Valve (K) is open.
- The Pressure Gauge Valve (B) is open.
- The Pressure Gauge Valve (H) is open.
- System Pressure Gauge (G) reads downstream pressure.
- Water Supply Pressure Gauge (C) reads upstream pressure.

Operation

When one or more sprinklers are activated, pressure is reduced downstream of the Alarm Valve. This reduction in pressure opens the Clapper in the Alarm Valve and allows water to flow through the alarm port into the alarm line, operating the Waterflow Pressure Alarm Switch (J) and the Water Motor Alarm via the Water Motor Alarm Control Valve (K). The main waterway is now open and water flows into the piping system.

Removing System from Service

Step 1. Close the Main Control Valve (A). Close the Water Motor Alarm Control Valve (K).

Step 2. Drain the system with the Main Drain Valve (F). Open all valves in the system to make sure that cross-mains and branch lines are vented and drained.

Placing the System Back in Service

Step 1. Replace sprinklers that have operated and sprinklers that are close to the fire.

Step 2. Remove the Hand-Hole Cover from the Alarm Check Valve (D). Check and clean the Clapper Facing and Seat Ring.

Step 3. Mount the Hand-Hole Cover.

Step 4. Close Main Drain Valve (F) and other valves in the system.

Step 5. Clean the strainers in the alarm line and the Water Motor Alarm Trim.

Step 6. Open the remote cross-main or branch-line vent connection.

Step 7. Slowly open the Main Control Valve (A) until the sound of flowing water just begins, then open the valve one more turn.

Step 8. Close the remote branch-line vent connection after the discharge of aerated water ceases, and the outlet has flowed fully for at least 15 seconds.

Step 9. Fully open the Main Control Valve (A) and lock it open.

Step 10. Open the Water Motor Alarm Control Valve (K).

Step 11. Reset the fire alarm panel and notify the central alarm station.

Weekly Test

NOTICE

Prior to closing any valves or activating any alarms, notify local security guards and the central alarm station if applicable.

Step 1. Open the Alarm Test Valve (E). Verify that the alarm signal created by the Waterflow Pressure Alarm Switch (J) is visible at the fire panel. If applicable, check the sound of the Water Motor Alarm — it must be clear and steady — and the signal of the supervisory switch.

Step 2. Close the Alarm Test Valve (E). Verify that the normal supply and system pressures are restored. If the supply pressure is below normal, use the instructions from the water supply to obtain the usual pressure.

Appendix Q of TFP990 AUGUST 2023
Summary Instructions (If problems occur, consult full document)
Wet Alarm Valve, AV-1-300, DN200, With Retarding Chamber

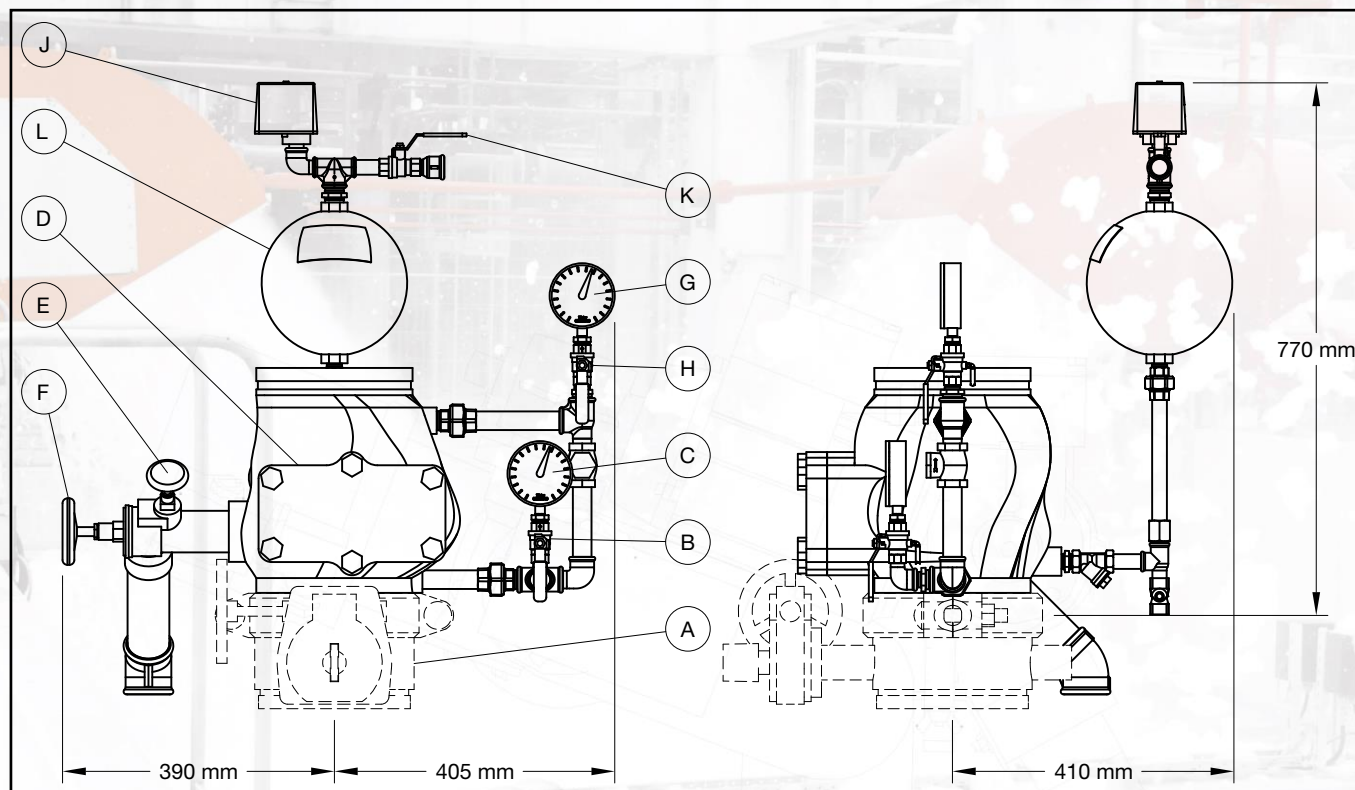

Normal Conditions

- The Main Control Valve (A) is opened and locked.
- The sprinkler system is filled with water and is pressurized.
- The Alarm Test Valve (E) and Main Drain Valve (F) are closed.
- The Water Motor Alarm Control Valve (K) is open.
- The Pressure Gauge Valve (B) is open.
- The Pressure Gauge Valve (H) is open.
- System Pressure Gauge (G) reads downstream pressure.
- Water Supply Pressure Gauge (C) reads upstream pressure.

Operation

When one or more sprinklers are activated, pressure is reduced downstream of the Alarm Valve. This reduction in pressure opens the Clapper in the Alarm Valve and allows water to flow through the alarm port into the alarm line, filling the Model RC-1 Retard Chamber (L) and operating the Waterflow Pressure Alarm Switch (J) and the Water Motor Alarm via the Water Motor Alarm Control Valve (K). The main waterway is now open and water flows into the piping system.

Removing System from Service

Step 1. Close the Main Control Valve (A). Close the Water Motor Alarm Control Valve (K).

Step 2. Drain the system with the Main Drain Valve (F). Open all valves in the system to make sure that cross-mains and branch lines are vented and drained.

Placing the System Back in Service

Step 1. Replace sprinklers that have operated and sprinklers that are close to the fire.

Step 2. Remove the Hand-Hole Cover from the Alarm Check Valve (D). Check and clean the Clapper Facing and Seat Ring.

Step 3. Mount the Hand-Hole Cover.

Step 4. Close Main Drain Valve (F) and other valves in the system.

Step 5. Clean the strainers in the alarm line and the Water Motor Alarm Trim.

Step 6. Open the remote cross-main or branch-line vent connection.

Step 7. Slowly open the Main Control Valve (A) until the sound of flowing water just begins, then open the valve one more turn.

Step 8. Close the remote branch-line vent connection after the discharge of aerated water ceases, and the outlet has flowed fully for at least 15 seconds.

Step 9. Fully open the Main Control Valve (A) and lock it open.

Step 10. Open the Water Motor Alarm Control Valve (K).

Step 11. Reset the fire alarm panel and notify the central alarm station.

Weekly Test

NOTICE

Prior to closing any valves or activating any alarms, notify local security guards and the central alarm station if applicable.

Step 1. Open the Alarm Test Valve (E). Verify that the alarm signal created by the Waterflow Pressure Alarm Switch (J) is visible at the fire panel. If applicable, check the sound of the Water Motor Alarm — it must be clear and steady.

Step 2. Close the Alarm Test Valve (E). Verify that the normal supply and system pressures are restored. If the supply pressure is below normal, use the instructions from the water supply to obtain the usual pressure.

Appendix R of TFP990 AUGUST 2023

Summary Instructions (If problems occur, consult full document)

Wet Alarm Valve, AV-1-300, DN200, With Retarding Chamber (Suitable for Supervisory)

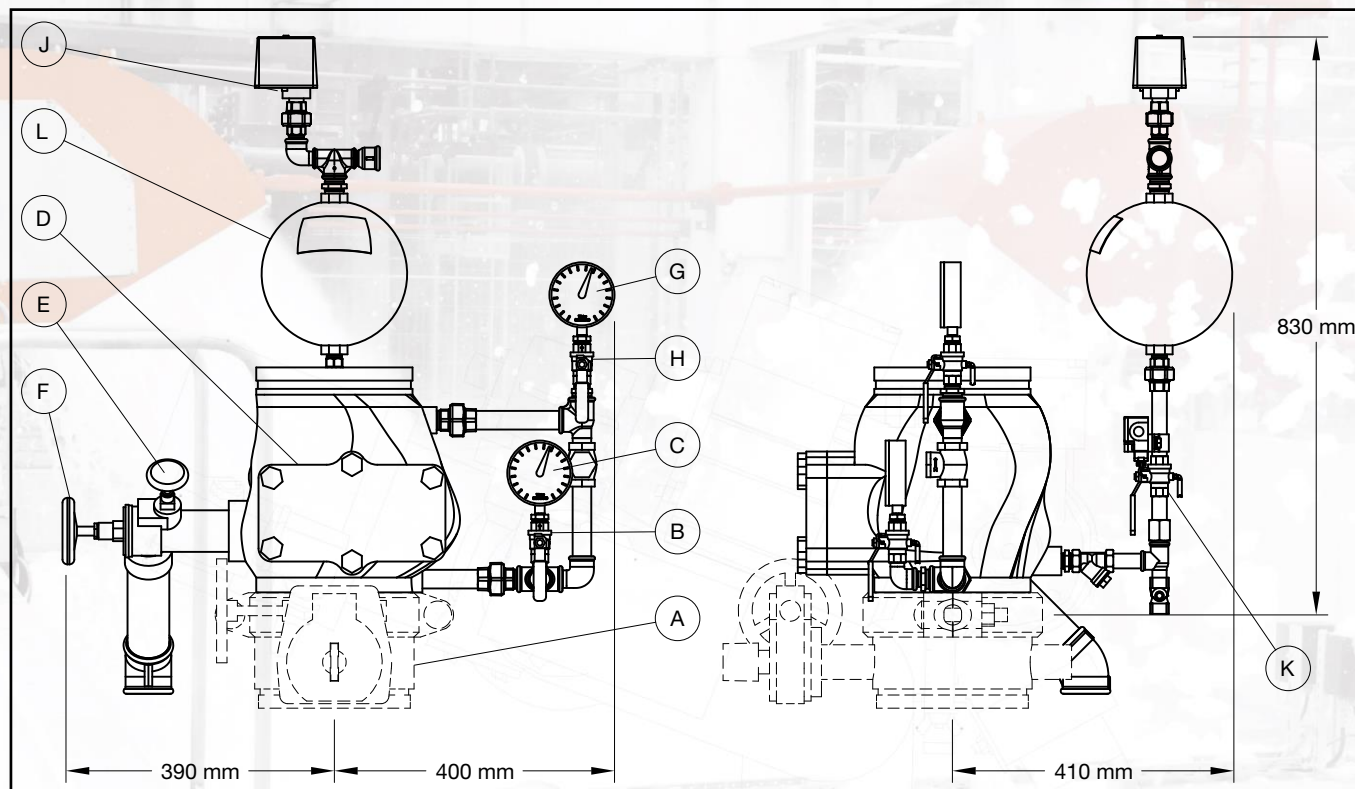

Normal Conditions

- The Main Control Valve (A) is opened and locked.
- The sprinkler system is filled with water and is pressurized.
- The Alarm Test Valve (E) and Main Drain Valve (F) are closed.
- The Water Motor Alarm Control Valve (K) is open.
- The Pressure Gauge Valve (B) is open.
- The Pressure Gauge Valve (H) is open.
- System Pressure Gauge (G) reads downstream pressure.
- Water Supply Pressure Gauge (C) reads upstream pressure.

Operation

When one or more sprinklers are activated, pressure is reduced downstream of the Alarm Valve. This reduction in pressure opens the Clapper in the Alarm Valve and allows water to flow through the alarm port into the alarm line, filling the Model RC-1 Retard Chamber (L) and operating the Waterflow Pressure Alarm Switch (J) and the Water Motor Alarm via the Water Motor Alarm Control Valve (K). The main waterway is now open and water flows into the piping system.

Removing System from Service

Step 1. Close the Main Control Valve (A). Close the Water Motor Alarm Control Valve (K).

Step 2. Drain the system with the Main Drain Valve (F). Open all valves in the system to make sure that cross-mains and branch lines are vented and drained.

Placing the System Back in Service

Step 1. Replace sprinklers that have operated and sprinklers that are close to the fire.

Step 2. Remove the Hand-Hole Cover from the Alarm Check Valve (D). Check and clean the Clapper Facing and Seat Ring.

Step 3. Mount the Hand-Hole Cover.

Step 4. Close Main Drain Valve (F) and other valves in the system.

Step 5. Clean the strainers in the alarm line and the Water Motor Alarm Trim.

Step 6. Open the remote cross-main or branch-line vent connection.

Step 7. Slowly open the Main Control Valve (A) until the sound of flowing water just begins, then open the valve one more turn.

Step 8. Close the remote branch-line vent connection after the discharge of aerated water ceases, and the outlet has flowed fully for at least 15 seconds.

Step 9. Fully open the Main Control Valve (A) and lock it open.

Step 10. Open the Water Motor Alarm Control Valve (K).

Step 11. Reset the fire alarm panel and notify the central alarm station.

Weekly Test

NOTICE

Prior to closing any valves or activating any alarms, notify local security guards and the central alarm station if applicable.

Step 1. Open the Alarm Test Valve (E). Verify that the alarm signal created by the Waterflow Pressure Alarm Switch (J) is visible at the fire panel. If applicable, check the sound of the Water Motor Alarm — it must be clear and steady — and the signal of the supervisory switch.

Step 2. Close the Alarm Test Valve (E). Verify that the normal supply and system pressures are restored. If the supply pressure is below normal, use the instructions from the water supply to obtain the usual pressure.



 Worldwide
 Contacts

www.tyco-fire.com

TFP990 Change History Appendix

| ISSUE DATE | NOTES |
|------------|--|
| 08-23 | Pages 6 to 21, Figures 4A to 11B, updated Pressure Switch model to PS10-1 or TPS10X1, previously just PS10-1, updated part numbers to 0260 or 100101, previously just 0260. |
| 06-23 | Page 22, Valve Setting Procedure, removed step instructing 'Check to see that the Handhole Cover bolts are tight. If not, crosstighten them,' formerly Step 2, all remaining step numbers updated accordingly. |
| 08-22 | Page 1, updated QR code and URL; Page 24, changed corporate address and telephone number to 1467 Elmwood Avenue, Cranston, RI 02910 Telephone +1-401-781-8220, formerly 1400 Pennbrook Parkway, Lansdale, PA 19446 Telephone +1-215-362-0700. |
| 04-22 | Page 1, added QR code and URL to allow convenient access to electronic version from printed document; Page 3, Approvals sub-section, added EAC Approved. |
| 03-21 | Changed pressure rating of flange drilling specification B16.42 to Class 150, formerly shown as Class 250. |
| 12-20 | Updated recommended handhole cover bolt torque specifications. |
| 05-20 | Updated recommended handhole cover bolt torque specifications. |
| 08-18 | Updated Tyco® branding and document format; Added Johnson Controls copyright; Added disclaimer stating specifications and information subject to change without notice; Added reference to Regulatory and Health Warning Technical Data Sheet TFP2300. |
| 12-16 | Added handhole cover installation procedure with bolt torque values. |
| 07-16 | Corrected Figure 5B Item 10 trim component description; Clarified Waterflow Pressure Alarm Switch nomenclature in Appendices Q and R. |
| 07-15 | Changed part number for accessory Model WMA-1 with red gong to 52-630-1-021R, formerly 52-630-1-021. |
| 12-13 | Updated nominal metric valve sizes. |
| 10-13 | Updated pre-assembled designs. |
| 04-11 | Added 2 1/2 in. (DN65) valve size. |
| 03-06 | Added repair parts. |
| 10-05 | New Technical Data Sheet TFP990 describes Model AV-1-300 Alarm Valve with European Trim. |

1467 Elmwood Avenue, Cranston, RI 02910 | Telephone +1-401-781-8220

© 2023 Johnson Controls. All rights reserved. All specifications and other information shown were current as of document revision date and are subject to change without notice.

 Johnson
 Controls

 NIP: 531-163-86-70
 REGON: 146196990