



 Worldwide
 Contacts | www.tyco-fire.com

DV-5a Automatic Water Control Valve Electric/ Electric Double Interlock Preaction Fire Protection Systems 1 1/2 Inch to 8 Inch (DN40 to DN200)

IMPORTANT

Refer to Technical Data Sheet TFP2300 for warnings pertaining to regulatory and health information.

Scan the QR code or enter the URL in a web browser to access the most up-to-date electronic version of this document. Data rates may apply.



docs.jci.com/tycofire/tfp1466



Available End Connections and Weights — lb/(kg)

End Connection		Nominal Valve Size ANSI Inches (DN)						
Inlet	Outlet	1 1/2 (40)	2 (50)	3 (80)	4 (100)	6 (150)	165,1 mm	8 (200)
Thread	Thread	26 (11,8)	25 (11,3)	N/A	N/A	N/A	N/A	N/A
Groove	Groove	25 (11,3)	25 (11,3)	60 (27,2)	95 (43,1)	177 (80,3)	177 (80,3)	327 (148,3)
Flange	Groove	N/A	N/A	66 (30,0)	106 (48,1)	190 (86,2)	N/A	346 (157,0)
Flange	Flange	N/A	N/A	72 (32,7)	116 (52,6)	204 (92,5)	N/A	365 (165,6)

General Description

The TYCO DV-5A Automatic Water Control Valves are diaphragm type valves that can be used in double interlock preaction fire protection systems. When properly trimmed, the double seat design of the DV-5A Valve also provides actuation of fire alarms upon system operation.

The diaphragm style design of the DV-5A Valve allows external resetting, providing for easy resetting of a deluge system without having to open a valve handhole cover to manually reposition a clapper and/or latch mechanism. Simply re-pressurizing the diaphragm chamber resets the valve.

The DV-5A features internal and external coating of the valve to provide corrosion resistance. The external corrosion resistance of the epoxy coating permits the use of the DV-5A in corrosive atmospheres associated with many types of industrial processing plants and outdoor installations.

The DV-5A Valves are offered with the

DV-5A Valve and separately ordered semi-assembled trim shown in Figures 6 and 7, or, for ease of installation, with DV-5A Valve completely trimmed with or without a System Main Control Valve.

Double interlock preaction systems are designed for use in applications, such as refrigerated areas, requiring the maximum degree of protection against inadvertent flooding of the sprinkler system piping. In order for a double interlock preaction system to automatically activate, two independent events must occur. First, the electric detection

system must operate, and secondly, an automatic sprinkler on the system piping must operate. Typically, the electric detection system is designed to operate before any automatic sprinkler. Operation of just the electric detection, or just the opening of a sprinkler will not allow the DV-5A Valve to open and permit water to flow into the normally dry sprinkler system piping. However, operation of just the electric detection system or the opening of a sprinkler (loss of system air pressure) will result in a supervisory alarm to notify the building occupants of a condition

Item	Description	Qty.	Nominal Valve Size ANSI Inch (DN)					
			1 1/2 (DN40)	2 (DN50)	3 (DN80)	4 (DN100)	6 (DN150) ^e	8 (DN200)
			P/N	P/N	P/N	P/N	P/N	P/N
1	Valve Body	1	N/R	N/R	N/R	N/R	N/R	N/R
2	Diaphragm	1	545000020	545000020	545000030	545000040	545000060	545000080
3	Diaphragm Cover	1	N/R	N/R	N/R	N/R	N/R	N/R
4	Hex Bolt, Short	2 ^a	545100001	545100001	545100002	545100003	545100004	545100003
5	Hex Bolt, Long	2	545100011	545100011	545100012	545100013	545100014	545100015
6	Lift Washer	2 ^b	N/A	N/A	545100021	545100022	545100023	545100022
7	Hex Nut	2	545100031	545100031	545100032	545100033	545100034	545100033
8	Hoist Ring	2	545100041	545100041	545100041	545100041	545100041	545100041
9	Flat Washer	2	N/A	N/A	545100024	545100025	545100026	545100025

NOTES

- a. Hex Bolt, Short, Qty. 6 in 6 and 8 inch (DN150 and DN200) assemblies.
 b. Lift Washer not used in 1 1/2 and 2 inch (DN40 and DN50) assemblies.
 c. N/R = Not Replaceable.

- d. Order replacements parts only via Part Numbers given, do not replace Hex Bolt, Hex Nut, Lift Washer or Hoist Ring with common hardware parts.
 e. Also applicable to metric 165,1 mm size.

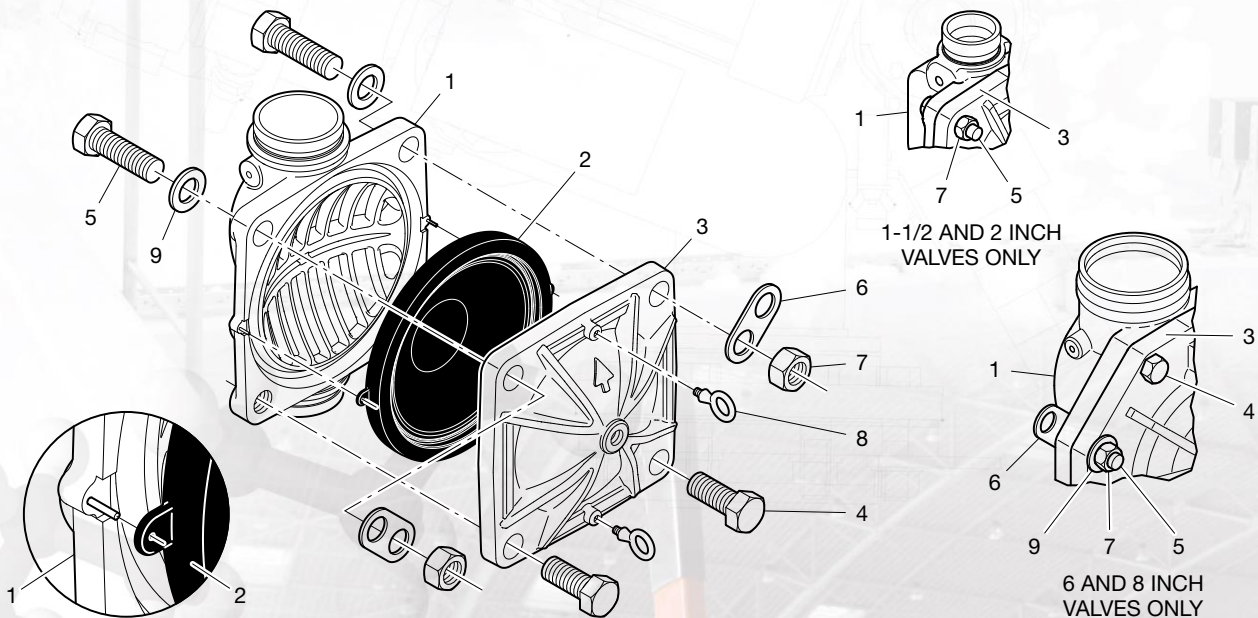
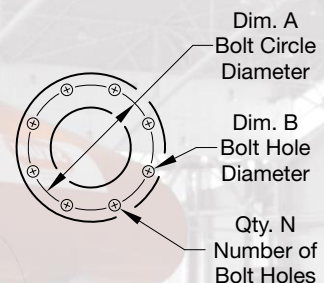

FIGURE 1
DV-5A VALVE ASSEMBLY AND REPLACEMENT PARTS

Nominal Valve Size ANSI Inches (DN)	Flange Drilling Specification											
	Nominal Dimensions in Inches and (mm)											
	ANSI B16.1 ^a (Class 125)			ISO 7005-2 (PN16) ^b			JIS B 2210 (10K)			AS 2129 (Table E)		
	A	B	N	A	B	N	A	B	N	A	B	N
3 (80)	6.00 (152,4)	0.75 (19,0)	4	6.30 (160,0)	0.75 (19,0)	8	5.90 (150,0)	0.59 (15,0)	8	5.75 (146,0)	0.71 (18,0)	4
4 (100)	7.50 (190,5)	0.75 (19,0)	8	7.09 (180,0)	0.75 (19,0)	8	6.89 (175,0)	0.60 (15,0)	8	7.00 (178,0)	0.71 (18,0)	8
6 (150)	9.50 (241,3)	0.88 (22,2)	8	9.45 (240,0)	0.91 (23,0)	8	9.45 (240,0)	0.75 (19,0)	8	9.25 (235)	0.87 (22,0)	8
8 (200)	11.75 (298,5)	0.88 (22,2)	8	11.61 (295,0)	0.91 (23,0)	12	11.42 (290,0)	0.75 (19,0)	12	11.50 (292,0)	0.87 (22,0)	8

NOTES:

- a. Same drilling as for ANSI B16.5 (Class 150) and ANSI B16.42 (Class 150)
 b. Same drilling as for BS 4504 Section 3.2 (PN16) and DIN 2532 (PN16)

TABLE A
FLANGE DRILLING SPECIFICATIONS

Port	Port Description	Port Sizes, NPT Inch per ANSI B1.20.1					
		1 1/2 (DN40)	2 (DN50)	3 (DN80)	4 (DN100)	6 (DN150) ^a	8 (DN200)
P1	Diaphragm Chamber Supply	1/2	1/2	1/2	1/2	1/2	1/2
P2	Water Supply Pressure & Alarm Test	1/2	1/2	1/2	1/2	1/2	1/2
P3	Alarm Actuation	3/4	3/4	3/4	3/4	3/4	3/4
P4	Automatic Drain Valve	1/2	1/2	1/2	1/2	1/2	1/2
P5	System Drain	3/4	3/4	3/4	3/4	3/4	3/4
P6	Main Drain	3/4	3/4	1 1/4	2	2	2
P7	System Air Supply	1/2	1/2	1/2	1/2	1/2	1/2

NOTES

a. Also applicable to metric 165,1 mm size.

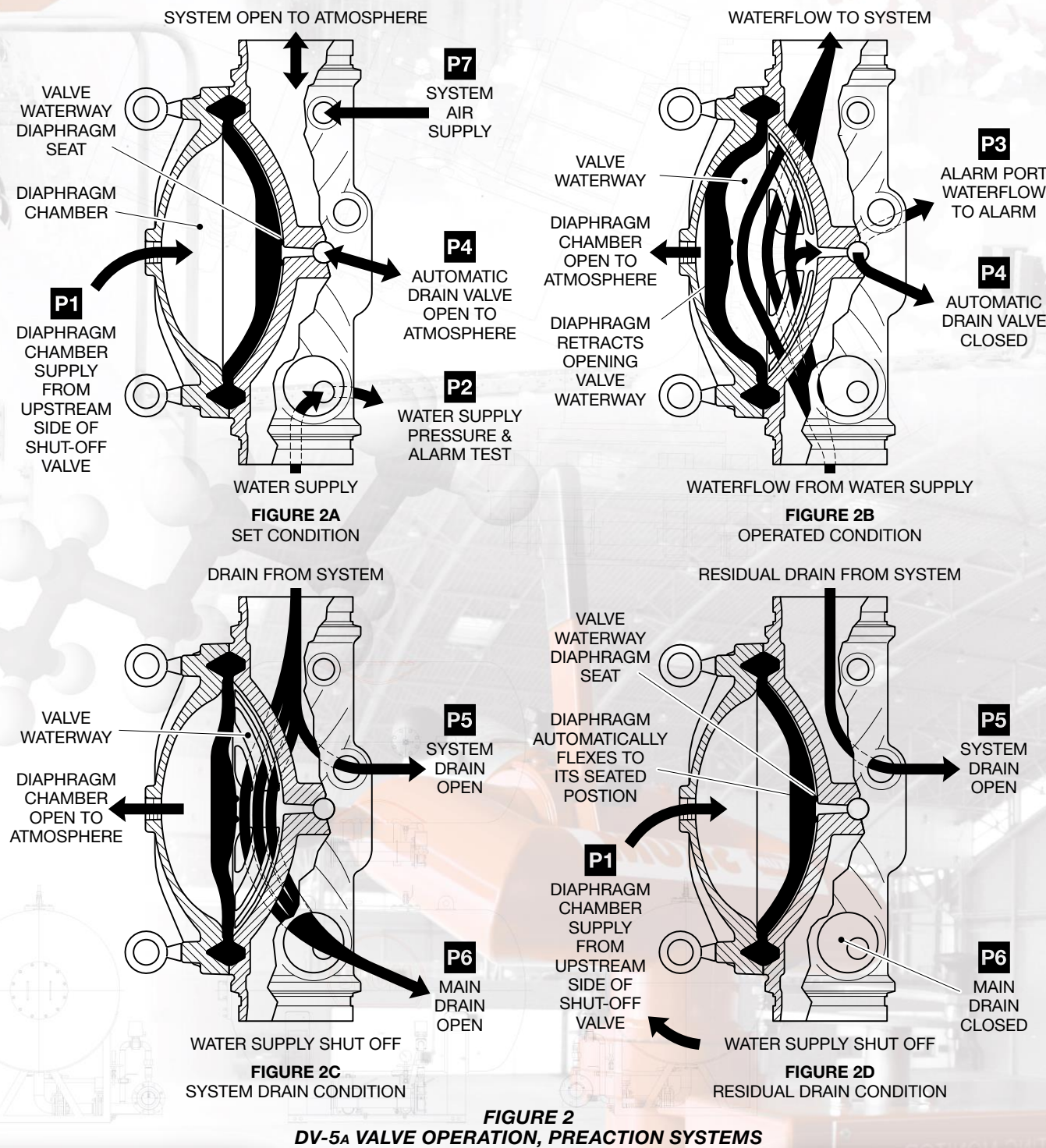

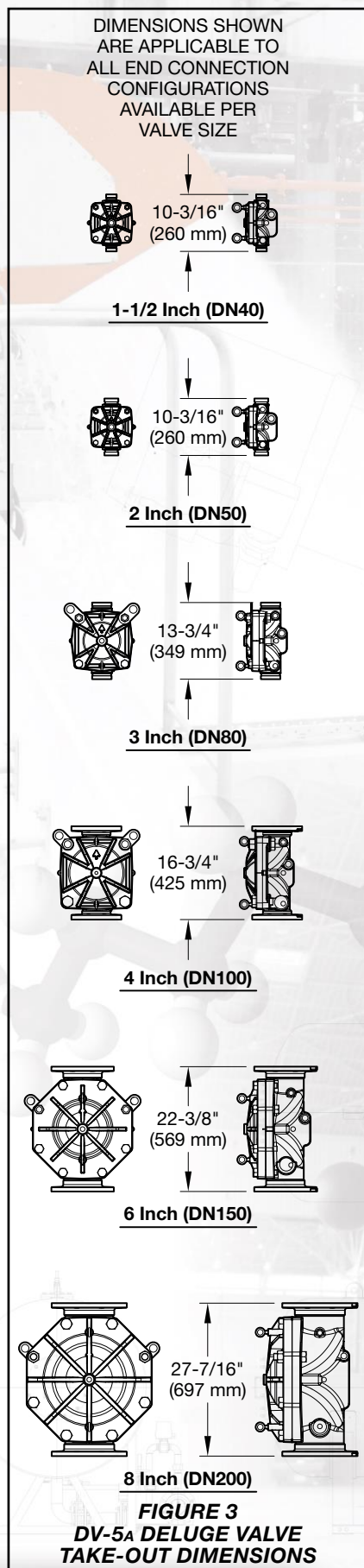

needing attention so as to avoid inadvertent flooding of the system piping.

A solenoid valve is used in the Electric/Electric Actuation to hold the DV-5A Valve closed by locking pressure in the diaphragm chamber of the DV-5A Valve. In the event of a fire, Zone 1 of a releasing panel is initiated by a fire detection or electric manual pull station, and Zone 2 of the releasing panel is initiated by a low pressure alarm switch triggered by loss of system air pressure due to the opening of an automatic sprinkler. Initiating of Zone 1 and 2 results in opening the solenoid valve to operate the DV-5A Valve.

NOTICE

The DV-5A Valves described herein must be installed and maintained in compliance with this document, as well as with the applicable standards of the NATIONAL FIRE PROTECTION ASSOCIATION (NFPA), in addition to the standards of any other authorities having jurisdiction. Failure to do so may impair the performance of these devices.

The owner is responsible for maintaining their fire protection system and devices in proper operating condition. Contact the installing contractor or product manufacturer with any questions.

Technical Data

Approvals
 UL/C-UL Listed
 FM Approved

Listings and Approvals are based on DV-5A being trimmed as described in this technical data sheet.

DV-5A Valve

Components for the 1 1/2 thru 8 in. (DN40 thru DN200) DV-5A Valves are shown in Figure 1. The DV-5A Valves are for vertical installations. They are rated for use at a service pressures of 20 to 300 psi (1,4 to 20,7 bar).

The take-out dimensions are shown in Figure 3, and flanged connections are available drilled per ANSI, ISO, AS, and JIS specifications (See Table A). Threaded inlet and outlet connections are available in NPT or ISO 7-1. Threaded port connections are NPT threaded.

NOTE: PN16 flanges are pressure rated to 16 bar.

Valve Trim

The maximum pressure rating for the Electric/Electric Double Interlock Pre-action Trim is dependent on separately ordered solenoid valve per Technical Data Sheet TFP2180.

Electric/Electric Double Interlock Pre-action Trim, when using the separately ordered QRS Electronic Accelerator, is based on the separately ordered QRS Electronic Accelerator per Technical Data Sheet TFP1100

When the system pressure is greater than 175 psi (12,1 bar), provision is to be made to replace the standard order 300 psi (20,7 bar) Water Pressure Gauges with separately ordered 600 psi (41,4 bar) Water Pressure Gauges.

If the addition of an Alarm Control Valve is desired or required by the local AHJ, the Alarm Control Valve noted as Item H in Figure 8 is to be a separately ordered electronically supervised normally open valve.

External trim connections are NPT threaded. EMEA trim is provided with NPT x ISO 7-1 thread adapters.

Pressure Loss

See Graph A

Actuation Options

See Electric/Electric Actuation subsection for additional information.

Materials of Construction

Valve Body

Epoxy coated ductile iron per ASTM A536-77, Grade 65-45-12

Diaphragm Cover

Epoxy coated ductile iron per ASTM A536-77, Grade 65-45-12

Diaphragm

Polyester fabric reinforced, TEFLON coated, EPDM rubber per ASTM D2000

Diaphragm Cover Fasteners

Aluminum zinc coated steel

Common Hardware Trim

- Common hardware pipe fittings are galvanized or black as required and are malleable per ASME B16.3.
- Common hardware pipe nipples are galvanized or black as required and are Schedule 40 per ASTM A53 or A135.
- Common hardware compression fitting are brass per ASTM B16
- Common hardware tubing is Type L per ASTM B88

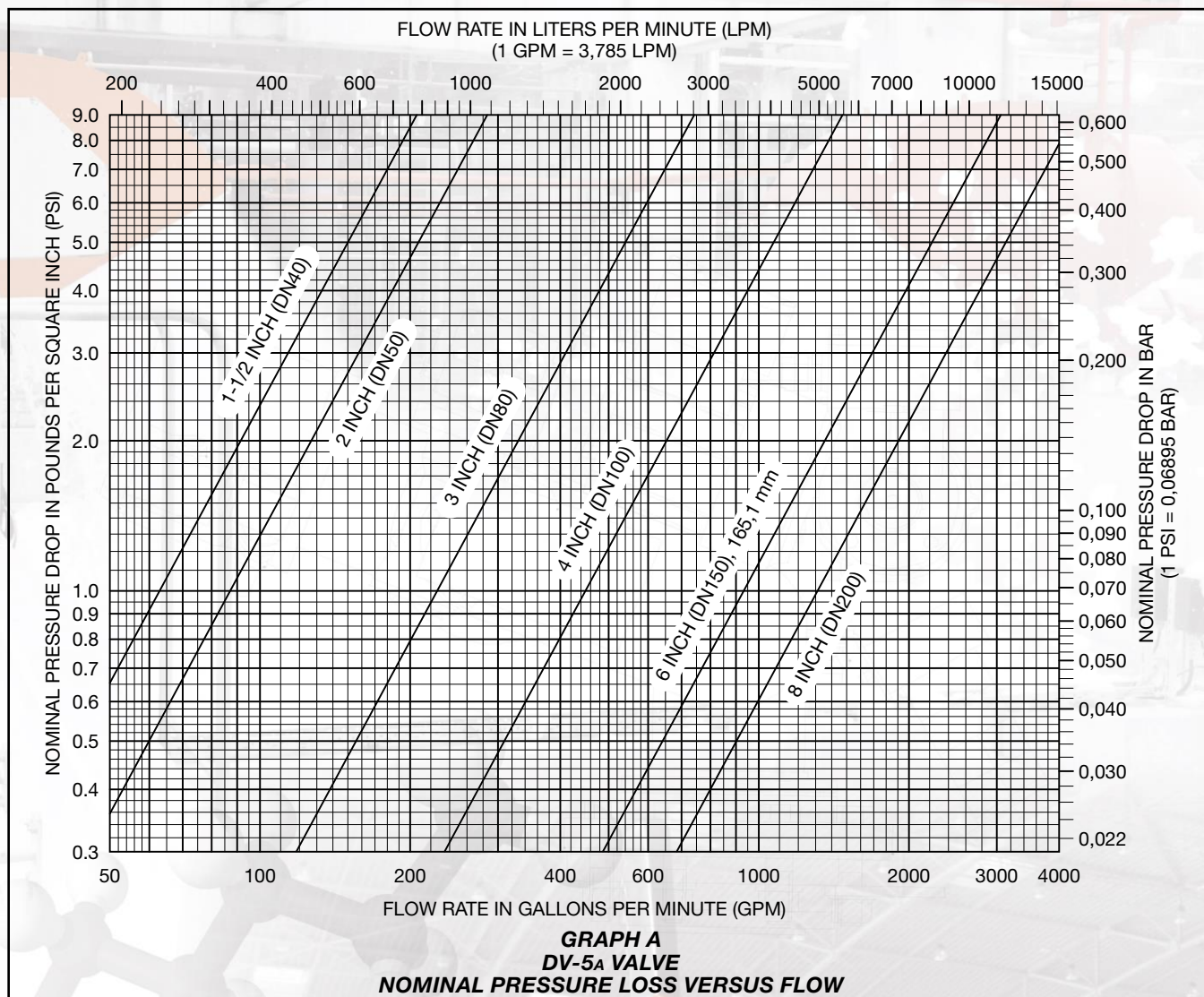

Operation

The TYCO DV-5A Valve is a diaphragm style valve that depends upon water pressure in the Diaphragm Chamber (see Figure 2A) to hold the Diaphragm closed against the water supply pressure.

When the DV-5A Valve is set for service, the Diaphragm Chamber is pressurized through the trim connections from the inlet side of the system's main control valve.

Opening of a solenoid valve for Electric/Electric Actuation (see Figure 4) trips the Model MRA-1 Manual Reset Actuator. Tripping the MRA-1 releases water from the DV-5A Diaphragm Chamber faster than it can be replenished through the 1/8 in. (3.2 mm) restriction located in the diaphragm chamber supply connection. Release of water through the MRA-1 results in a rapid pressure drop in the DV-5A Diaphragm Chamber. The force differential applied through the Diaphragm to hold the Diaphragm in the set position is then reduced below the valve trip point. The water supply pressure then forces the Diaphragm open permitting water to flow into the system piping, as well as through the Alarm Port to actuate the system alarms (see Figure 2B).

Upon opening of the DV-5A Valve, the Model MRA-1 Manual Reset Actuator opens to constantly vent the DV-5A Diaphragm Chamber to "hydraulically latch" the DV-5A in the tripped position until manually reset.

See Electric/Electric Actuation sub-section for additional information.

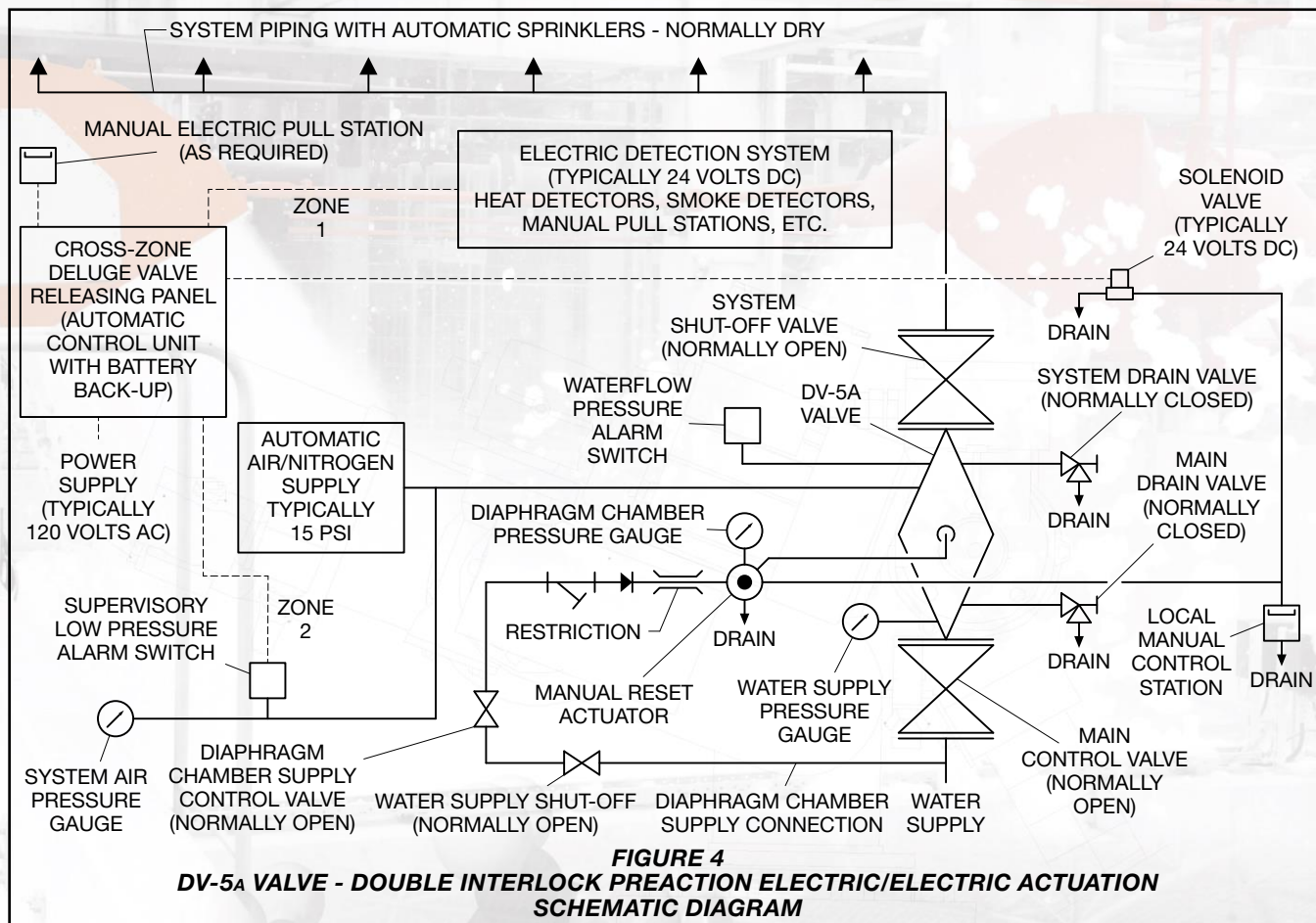

Electric/ Electric Actuation

System Design Considerations

Because a double interlock preaction system requires time for a drop in system air pressure to occur (concurrently with the response time for the separate fire detection system) before it will allow water to enter the system piping, this system has characteristics similar to a dry pipe sprinkler system. Therefore, the system design considerations for a dry pipe system are normally applied to a double interlock preaction system, — including: a 30% increase in design area; a maximum 1 minute water delivery time for system capacities of 500 gallons (1890 liters) or more; and, prohibition of gridded system piping.

As an option, the DV-5A Double Interlock Preaction System with Electric/Electric Actuation may be equipped with the Model QRS Electronic Accelerator to reduce the time to valve actuation following the operation of the

electric detection system and one or more automatic sprinklers. Refer to Technical Data Sheet TFP1100 for details regarding installation requirements and pressure ratings.

Note: Use of the Model QRS Electronic Accelerator can permit system volumes of 750 gallons (2840 Liters) without applying the minimum one minute water delivery time.

In order to readily perform the System Inspection Procedure described in the Care and Maintenance section, it is recommended that a System Shut-Off Valve be installed above the DV-5A Valve, as shown in Figure 4. The System Shut-Off Valve should be a listed or approved (as appropriate) indicating valve with a supervisory switch to monitor the normally open position.

Detection System

The Double Interlock Preaction System With Electric/Electric Actuation Trim provides for electric operation of the DV-5A Valve by a detection system consisting of electrical devices such as heat sensitive thermostats, smoke detectors, and/or electric manual pull stations. Information on the various types of separately ordered Solenoid Valves that may be used with this trim

package is given in Technical Data Sheet TFP2180. Nominal installation dimensions for the Double Interlock Preaction System With Electric/Electric Actuation Trim are shown in Figure 7.

The cross-zone deluge valve releasing panel (automatic control unit) with battery back-up, fire detection devices, manual pull stations, and signaling devices, that are utilized with the Double Interlock Preaction System with Electric/Electric Actuation must be UL Listed, ULC Listed, C-UL Listed, or FM Approved, as applicable.

NOTES:

The normally closed, de-energized solenoid Valve is separately ordered and selected based on the required laboratory approval acceptable to the authority having jurisdiction. Refer to technical data Sheet TFP2180 for specific laboratory approvals.

Consult with the authority having jurisdiction regarding installation criteria pertaining to electric actuation circuitry.

Due to the functionality of the Model MRA-1 Manual Reset Actuator, the release circuit of the releasing panel need only provide the typical ten minutes of alarm condition intended to energize the Solenoid Valve to

open. After the ten minute duration, at which point should the Solenoid Valve become de-energized and close (especially while operating under battery back-up), the MRA-1 will have already automatically opened, thereby preventing the DV-5A Diaphragm Chamber from becoming re-pressurized, and preventing an inadvertent closing of the DV-5A during a fire event.

WARNING

If the delay between electric actuation and subsequent sprinkler activation is anticipated to be greater than 10 minutes, adjust the battery back-up calculation accordingly. Inadequate battery back-up may result in failure of the system to operate in the event of a fire during a power failure.

Releasing Circuit

The recommended arrangement is to equip the releasing circuit with a Potter RCDS-1 Releasing Circuit Switch, or equivalent. The RCDS-1 provides for a temporary disconnect (de-energized) of the Solenoid Valve during Step 9 of the Valve Resetting Procedure.

System Air Pressure Requirements

The recommended system air pressure for the Double Interlock Preaction System with Electric/Electric Actuation is nominally 15 psi (1,0 bar), irrespective of the water supply pressure. The use of a higher system air pressure may or may not adversely affect water delivery time, and the use of a lower system air pressure may prevent clearing the alarm of the Low Pressure Switch on increasing pressure. The Low Pressure Switch is field set to alarm at nominally 12 psi (0,8 bar) on decreasing pressure when using a nominal system air pressure of 15 psi (1,0 bar). It is recommended that the system air pressure be maintained by either of the following methods:

- A maximum 200 psi (13,8 bar) plant air supply in combination with the Model AMD-1 Air Maintenance Device described in Technical Data Sheet TFP1221
- A maximum 3000 psi (206,9 bar) nitrogen cylinder in combination with the Model AMD-3 Nitrogen Maintenance Device described in Technical Data Sheet TFP1241

NOTES:

It is recommended that the pressure maintenance device be of a type that maintains a constant system pressure, i.e., a pressure maintenance device that utilizes a pressure regulator versus a pressure switch (e.g., the AMD-1 or AMD-3). Use of a pressure switch operated pressure maintenance device with a cut-in/cut-out differential may result in a delay in the operation of the system due to a fire,

because of the cut-out pressure being higher than the recommended nominal system air pressure.

The dew point of the air or nitrogen supply, for a system exposed to freezing conditions, must be maintained below the lowest ambient temperature to which the system piping will be exposed. Introduction of moisture into the system piping can create ice build up which could prevent proper operation of the system.

The Air Pressure Relief Valve is typically field set to crack open at a pressure of about 20 psi (1,4 bar) when using a nominal system air pressure of 15 psi (1,0 bar).

Installation

The TYCO DV-5A Valve is to be installed in accordance with this section.

NOTICE

DV-5A Automatic Water Control Valves are designed to be used in freshwater systems. When the supply is from an alternative source such as brackish water, saltwater, or contains additives such as foam, the limited warranty is reduced to one year from the time of installation. An increase in frequency of inspections is required when the valve is exposed to such supplies and other corrosive conditions or chemicals that could impact valve materials or the operation of the assembly. The system and all components must be designed accordingly for the increased demand. It is required to thoroughly flush the valve and trim assembly with freshwater and reset to the set condition after each operation.

Proper operation of the DV-5A Valves depends upon their trim being installed in accordance with the instructions given in this technical data sheet. Failure to follow the appropriate trim diagram may prevent the DV-5A Valve from functioning properly, as well as void approvals and the manufacturer's warranties.

The DV-5A Valve must be installed in a readily visible and accessible location.

The DV-5A Valve and associated trim must be maintained at a minimum temperature of 40°F (4°C).

Heat tracing of the DV-5A Valve or its associated trim is not permitted. Heat tracing can result in the formation of hardened mineral deposits that are capable of preventing proper operation. Always open the system control valves slowly to avoid a sudden rush of water entering the system.

The DV-5A Valve is to be installed in accordance with the following criteria:

Step 1. All nipples, fittings, and devices must be clean and free of scale and burrs before installation. Use pipe thread sealant sparingly on male pipe threads only.

Step 2. The DV-5A Valve must be trimmed in accordance with one of the trim illustrations shown in Figure 5.

Note: *If the addition of an Alarm Control Valve is desired or required by the local AHJ, the Alarm Control Valve noted as Item H in Figure 8 is to be a separately ordered electronically supervised normally open valve.*

Step 3. Care must be taken to ensure that check valves, strainers, globe valves, etc., are installed with the flow arrows in the proper direction.

Step 4. Drain tubing to the Drip Funnel must be installed with smooth bends that will not restrict flow.

Step 5. The Main Drain and Drip Funnel Drain may be interconnected provided a check valve is located at least 12 in. (300 mm) below the Drip Funnel.

Step 6. Suitable provision must be made for disposal of drain water. Drainage water must be directed such that it will not cause accidental damage to property or danger to persons.

Step 7. Connect the Diaphragm Supply Valve to the inlet side of the System Main Control Valve in order to facilitate setting of the DV-5A Valve (see Figure 8).

Step 8. An Inspector's Test Connection is to be located on the sprinkler system at the most hydraulically demanding location.

Step 9. A suitable automatic air (nitrogen) supply, as described in the applicable Electric/Electric Actuation sub-section, is to be installed in accordance with the applicable technical data sheet. The minimum air pressure is to be in accordance with the referenced sub-sections.

Step 10. A desiccant dryer, when specified, is to be installed between a drip leg and the Air Maintenance Device.

Step 11. The Low Pressure Switch on falling pressure in the Electric/Electric Actuation is to be adjusted so that the low pressure alarm setting is set at 3 psi (0,21 bar) below the system air pressure.

Step 12. Unused Pressure Alarm Switch connections must be plugged.

Step 13. The Pressure Relief Valve on rising pressure is to be at 5 psi (0,34 bar) higher than the required system air pressure, or be reset in accordance with the requirements of the authority having jurisdiction.

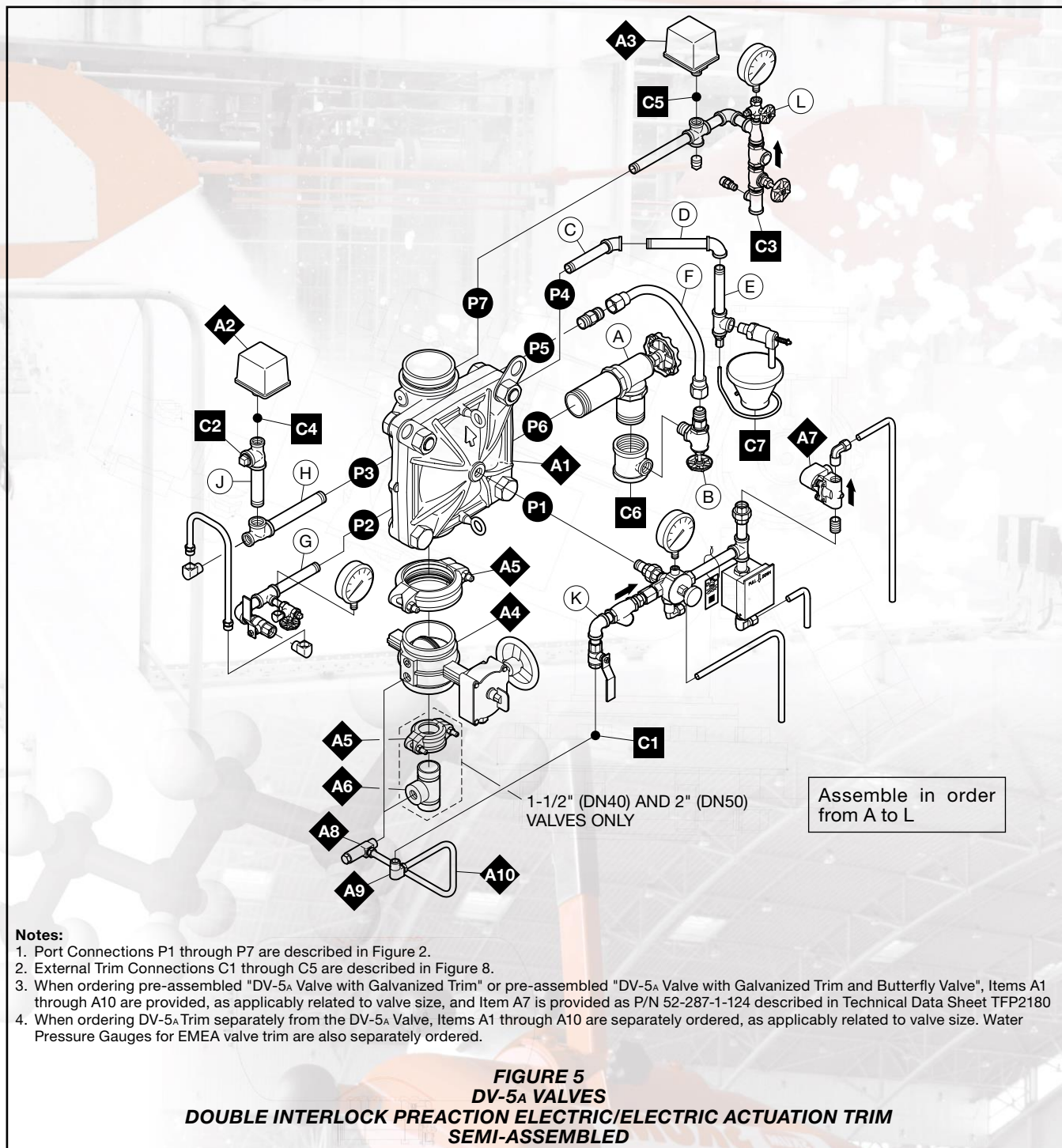

Notes:

1. Port Connections P1 through P7 are described in Figure 2.
2. External Trim Connections C1 through C5 are described in Figure 8.
3. When ordering pre-assembled "DV-5a Valve with Galvanized Trim" or pre-assembled "DV-5a Valve with Galvanized Trim and Butterfly Valve", Items A1 through A10 are provided, as applicably related to valve size, and Item A7 is provided as P/N 52-287-1-124 described in Technical Data Sheet TFP2180
4. When ordering DV-5a Trim separately from the DV-5a Valve, Items A1 through A10 are separately ordered, as applicably related to valve size. Water Pressure Gauges for EMEA valve trim are also separately ordered.

To reset the Pressure Relief Valve, first loosen the jam nut and then adjust the cap accordingly, clockwise for a higher pressure setting or counter clockwise for a lower pressure setting. After verifying the desired pressure setting, tighten the jam nut.

Step 14. Conduit and electrical connections are to be made in accordance with the applicable standards of the approval agency.

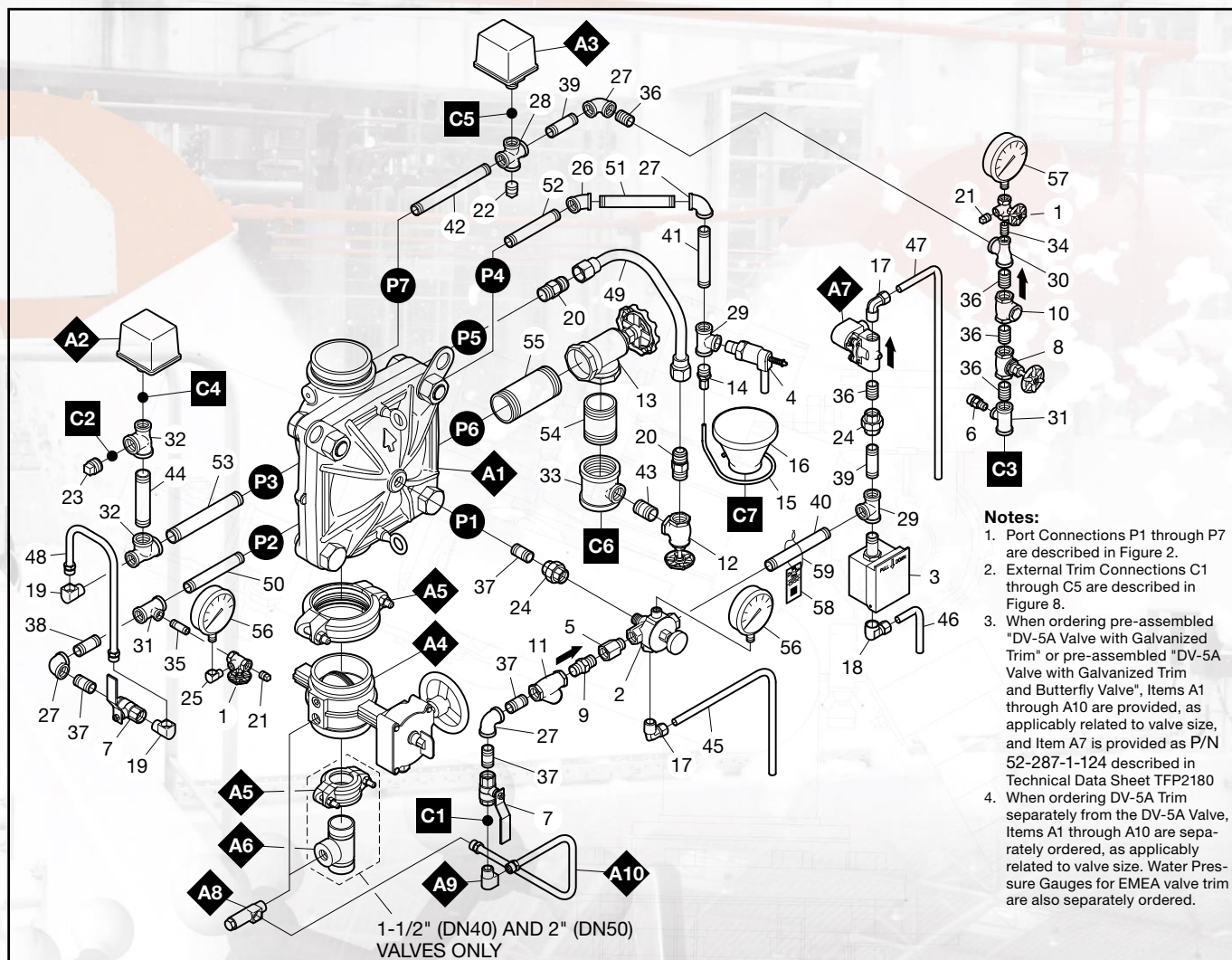
Step 15. Before a system hydrostatic test is performed, the DV-5a Diaphragm Chamber is to be depressurized, the Automatic Drain Valve is to be temporarily replaced with a plug, and the Diaphragm Cover Bolts must be uniformly and securely tightened using a cross-draw sequence. After tightening, double-check to make certain that all of the Diaphragm Cover Bolts are securely tightened. See Table B in the Care and Maintenance section for torque specifications.



- Notes:**
1. Port Connections P1 through P7 are described in Figure 2.
 2. External Trim Connections C1 through C5 are described in Figure 8.
 3. When ordering pre-assembled "DV-5A Valve with Galvanized Trim" or pre-assembled "DV-5A Valve with Galvanized Trim and Butterfly Valve", Items A1 through A10 are provided, as applicably related to valve size, and Item A7 is provided as P/N 52-287-1-124 described in Technical Data Sheet TFP2180
 4. When ordering DV-5A Trim separately from the DV-5A Valve, Items A1 through A10 are separately ordered, as applicably related to valve size. Water Pressure Gauges for EMEA valve trim are also separately ordered.

ITEM	QTY	DESCRIPTION	CH	1-1/2 IN. (DN40)	2 IN. (DN50)	3 IN. (DN80)	4 IN. (DN100)	6 IN. (DN150) ^b	8 IN. (DN200)
1	2	1/4" GAUGE TEST VALVE		460051003	460051003	460051003	460051003	460051003	460051003
2	1	MRA-1 MANUAL RESET ACTUATOR		545001000	545001000	545001000	545001000	545001000	545001000
3	1	MC-2 MANUAL CONTROL STATION		545002000	545002000	545002000	545002000	545002000	545002000
4	1	AD-3 AUTOMATIC DRAIN VALVE		547932004	547932004	547932004	547932004	547932004	547932004
5	1	PRIMING SUPPLY RESTRICTION		545100051	545100051	545100051	545100051	545100051	545100051
6	1	1/4" PRESSURE RELIEF VALVE		923431020	923431020	923431020	923431020	923431020	923431020
7	2	1/2" BALL VALVE		460501004	460501004	460501004	460501004	460501004	460501004
8	1	1/2" GLOBE VALVE		460471005	460471005	460471005	460471005	460471005	460471005
9	1	1/2" SPRING LOADED CHECK VALVE		923221003	923221003	923221003	923221003	923221003	923221003
10	1	1/2" SWING CHECK VALVE		460491007	460491007	460491007	460491007	460491007	460491007
11	1	1/2" Y-STRAINER		523531006	523531006	523531006	523531006	523531006	523531006
12	1	3/4" ANGLE VALVE		460481010	460481010	460481010	460481010	460481010	460481010
13	1	ANGLE VALVE		460481010	460481010	460481011	460481012	460481012	460481012
14	1	DRIP FUNNEL BRACKET CONNECTOR		922111005	922111005	922111005	922111005	922111005	922111005
15	1	DRIP FUNNEL BRACKET		922111003	922111003	922111003	922111003	922111003	922111003
16	1	DRIP FUNNEL		923431007	923431007	923431007	923431007	923431007	923431007
17	2	COMP. FITTING 90° 1/2" MNPT x 1/2" OD TUBE		1001253-01	1001253-01	1001253-01	1001253-01	1001253-01	1001253-01
18	1	COMP. FITTING 90° 1/2" FNPT x 1/2" OD TUBE		1001420-01	1001420-01	1001420-01	1001420-01	1001420-01	1001420-01
19	2	FLARE FITTING 90° 1/2" NPT x 1/2" TUBE		545100062	545100062	545100062	545100062	545100062	545100062
20	2	FLARE FITTING 3/4" NPT x 3/4" TUBE		545100063	545100063	545100063	545100063	545100063	545100063
21	2	PIPE PLUG	✓	1/4"	1/4"	1/4"	1/4"	1/4"	1/4"
22	1	PIPE PLUG	✓	1/2"	1/2"	1/2"	1/2"	1/2"	1/2"
23	1	PIPE PLUG	✓	3/4"	3/4"	3/4"	3/4"	3/4"	3/4"
24	2	UNION	✓	1/2"	1/2"	1/2"	1/2"	1/2"	1/2"

FIGURE 6 (1 OF 2)
DV-5a VALVES
DOUBLE INTERLOCK PREACTION ELECTRIC/ELECTRIC ACTUATION TRIM
EXPLODED VIEW

ITEM	QTY	DESCRIPTION	CH	1-1/2 IN. (DN40)	2 IN. (DN50)	3 IN. (DN80)	4 IN. (DN100)	6 IN. (DN150) ^a	8 IN. (DN200)
25	1	STREET ELBOW	✓	1/4" x 90°	1/4" x 90°	1/4" x 90°	1/4" x 90°	1/4" x 90°	1/4" x 90°
26	1	ELBOW	✓	1/2" x 45°	1/2" x 45°	1/2" x 45°	1/2" x 45°	1/2" x 45°	1/2" x 45°
27	4	ELBOW	✓	1/2" x 90°	1/2" x 90°	1/2" x 90°	1/2" x 90°	1/2" x 90°	1/2" x 90°
28	1	CROSS	✓	1/2"	1/2"	1/2"	1/2"	1/2"	1/2"
29	2	TEE	✓	1/2"	1/2"	1/2"	1/2"	1/2"	1/2"
30	1	REDUCING TEE	✓	1/2" x 1/4" x 1/2"	1/2" x 1/4" x 1/2"	1/2" x 1/4" x 1/2"	1/2" x 1/4" x 1/2"	1/2" x 1/4" x 1/2"	1/2" x 1/4" x 1/2"
31	2	REDUCING TEE	✓	1/2" x 1/2" x 1/4"	1/2" x 1/2" x 1/4"	1/2" x 1/2" x 1/4"	1/2" x 1/2" x 1/4"	1/2" x 1/2" x 1/4"	1/2" x 1/2" x 1/4"
32	2	REDUCING TEE	✓	3/4" x 1/2" x 3/4"	3/4" x 1/2" x 3/4"	3/4" x 1/2" x 3/4"	3/4" x 1/2" x 3/4"	3/4" x 1/2" x 3/4"	3/4" x 1/2" x 3/4"
33	1	REDUCING TEE	✓	3/4" x 3/4" x 3/4"	3/4" x 3/4" x 3/4"	1-1/4" x 1-1/4" x 3/4"	2" x 2" x 3/4"	2" x 2" x 3/4"	2" x 2" x 3/4"
34	1	PIPE NIPPLE	✓	1/4" x CLOSE	1/4" x CLOSE	1/4" x CLOSE	1/4" x CLOSE	1/4" x CLOSE	1/4" x CLOSE
35	1	PIPE NIPPLE	✓	1/4" x 1 1/2"	1/4" x 1 1/2"	1/4" x 1 1/2"	1/4" x 1 1/2"	1/4" x 1 1/2"	1/4" x 1 1/2"
36	5	PIPE NIPPLE	✓	1/2" x CLOSE	1/2" x CLOSE	1/2" x CLOSE	1/2" x CLOSE	1/2" x CLOSE	1/2" x CLOSE
37	4	PIPE NIPPLE	✓	1/2" x 1 1/2"	1/2" x 1 1/2"	1/2" x 1 1/2"	1/2" x 1 1/2"	1/2" x 1 1/2"	1/2" x 1 1/2"
38	1	PIPE NIPPLE	✓	1/2" x 2"	1/2" x 2"	1/2" x 2"	1/2" x 2"	1/2" x 2"	1/2" x 2"
39	2	PIPE NIPPLE	✓	1/2" x 2 1/2"	1/2" x 2 1/2"	1/2" x 2 1/2"	1/2" x 2 1/2"	1/2" x 2 1/2"	1/2" x 2 1/2"
40	1	PIPE NIPPLE	✓	1/2" x 4 1/2"	1/2" x 4 1/2"	1/2" x 4 1/2"	1/2" x 4 1/2"	1/2" x 4 1/2"	1/2" x 4 1/2"
41	1	PIPE NIPPLE	✓	1/2" x 5"	1/2" x 5"	1/2" x 5"	1/2" x 5"	1/2" x 5"	1/2" x 5"
42	1	PIPE NIPPLE	✓	1/2" x 8 1/2"	1/2" x 8 1/2"	1/2" x 8 1/2"	1/2" x 8 1/2"	1/2" x 8 1/2"	1/2" x 8 1/2"
43	1	PIPE NIPPLE	✓	3/4" x 1 1/2"	3/4" x 1 1/2"	3/4" x 1 1/2"	3/4" x 1 1/2"	3/4" x 1 1/2"	3/4" x 1 1/2"
44	1	PIPE NIPPLE	✓	3/4" x 4 1/2"	3/4" x 4 1/2"	3/4" x 4 1/2"	3/4" x 4 1/2"	3/4" x 4 1/2"	3/4" x 4 1/2"
45	1	TUBING, MRA-1 DRAIN		545100065	545100065	545100066	535002140	535002160	535002180
46	1	TUBING, MC-2 DRAIN		535000220	535000220	535000230	535000240	535000260	535000280
47	1	TUBING, SOLENOID DRAIN		535001020	535001020	535000630	535000640	535000660	535000680
48	1	TUBING ASSY, ALARM TEST INTERCONNECT		535000320	535000320	535000330	535000340	535000360	535000380
49	1	TUBING ASSY, SYSTEM DRAIN		535000420	535000420	535000430	535000440	535000460	535000480
50	1	PIPE NIPPLE	✓	1/2" x 3 1/2"	1/2" x 3 1/2"	1/2" x 4 1/2"	1/2" x 5 1/2"	1/2" x 5 1/2"	1/2" x 6 3/4"
51	1	PIPE NIPPLE	✓	1/2" x 5"	1/2" x 5"	1/2" x 5 1/2"	1/2" x 5 1/2"	1/2" x 5 1/2"	1/2" x 6 1/2"
52	1	PIPE NIPPLE	✓	1/2" x 5"	1/2" x 5"	1/2" x 4 1/2"	1/2" x 5"	1/2" x 7 1/2"	1/2" x 9 1/2"
53	1	PIPE NIPPLE	✓	3/4" x 5"	3/4" x 5"	3/4" x 6"	3/4" x 7"	3/4" x 9"	3/4" x 11 1/2"
54	1	PIPE NIPPLE	✓	3/4" x 4 1/2"	3/4" x 4 1/2"	1-1/4" x 3 1/4"	2" x 3"	2" x 3"	2" x 3"
55	1	PIPE NIPPLE	✓	3/4" x 6 1/2"	3/4" x 6 1/2"	1-1/4" x 5 1/2"	2" x 5"	2" x 6"	2" x 8"
56	2	WATER PRESSURE GAUGE, 300 PSI / 2000 kPa (AMER/APAC)		923431005	923431005	923431005	923431005	923431005	923431005
	2	WATER PRESSURE GAUGE, 20 bar / 2000 kPa (EMEA)		025500013	025500013	025500013	025500013	025500013	025500013
57	1	AIR PRESSURE GAUGE, 80 PSI / 550 kPa RETARDED TO 250PSI / 1750 kPa		923431012	923431012	923431012	923431012	923431012	923431012
58	1	LABEL		545003005	545003005	545003005	545003005	545003005	545003005
59	1	LABEL WIRE		—	—	—	—	—	—
A1	1	DV-5A VALVE		SEE ORDERING PROCEDURE, SEPARATE DV-5A VALVES WITHOUT TRIM, FOR PART NUMBERS					
A2	1	WATERFLOW PRESSURE ALARM SWITCH, DOUBLE CONTACTS (APAC)		25710 or 100102	25710 or 100102	25710 or 100102	25710 or 100102	25710 or 100102	25710 or 100102
	1	WATERFLOW PRESSURE ALARM SWITCH, SINGLE CONTACTS (EMEA)		0260 or 100101	0260 or 100101	0260 or 100101	0260 or 100101	0260 or 100101	0260 or 100101
	1	WATERFLOW PRESSURE ALARM SWITCH, DOUBLE CONTACTS (AMER)		25710	25710	25710	25710	25710	25710
A3	1	LOW AIR PRESSURE ALARM SWITCH, DOUBLE CONTACTS (APAC)		25730 or 100402	25730 or 100402	25730 or 100402	25730 or 100402	25730 or 100402	25730 or 100402
	1	LOW AIR PRESSURE ALARM SWITCH, DOUBLE CONTACTS (AMER)		25730	25730	25730	25730	25730	25730
	1	LOW AIR PRESSURE ALARM SWITCH, DOUBLE CONTACTS (EMEA)		0262 or 100401	0262 or 100401	0262 or 100401	0262 or 100401	0262 or 100401	0262 or 100401
A4	1	BUTTERFLY VALVE, G x G		51024A	51021A	—	—	—	—
	1	BFV-300 BUTTERFLY VALVE, G x G		—	—	59300G030WS	59300G040WS	59300G060WS	59300G080WS
A5	2	FIGURE 577 RIGID GROOVED COUPLING		57715ACP	57720ACP	—	—	—	—
	1	FIGURE 577 RIGID GROOVED COUPLING		—	—	57730ACP	57740ACP	57760ACP	57780ACP
A6	1	GROOVE x THREADED OUTLET WELDED TEE		545004000	545004001	—	—	—	—
A7	1	SOLENOID VALVE NORMALLY CLOSED (SEPARATELY ORDERED)		SEE TFP2180	SEE TFP2180	SEE TFP2180	SEE TFP2180	SEE TFP2180	SEE TFP2180
A8	1	INVERTED FLARE SHUT-OFF VALVE ^a		545100100	545100100	545100099	545100100	545100100	545100100
A9	1	FLARE FITTING 90° 1/2" NPT x 1/2" TUBE		545100062	545100062	545100062	545100062	545100062	545100062
A10	1	TUBING ASSY, DIAPHRAGM CHAMBER SUPPLY		540000015	540000020	540000030	540000040	540000060	540000080

NOTES

- a. Not VdS Approved
 b. Also applicable to metric 165,1 mm size.
 CH - Common Hardware - Refer to Materials of Construction section for specifications.

FIGURE 6 (2 OF 2)
DV-5A VALVES
DOUBLE INTERLOCK PREACTION ELECTRIC/ELECTRIC ACTUATION TRIM
EXPLODED VIEW

Nominal Valve Size ANSI Inches (DN)	Inches (mm)								
	A	B	C	D	E	F	G	H	J
1 1/2 (40)	2.8 (71)	9.7 (246)	9.8 (249)	15.7 (399)	16.0 (406)	7.4 (188)	10.2 (259)	8.02 (204)	1.2 (31)
2 (50)	2.8 (71)	9.7 (246)	9.8 (249)	15.7 (399)	16.0 (406)	7.4 (188)	10.2 (259)	8.09 (205)	2.9 (74)
3 (80)	4.0 (102)	10.7 (272)	11.5 (292)	16.3 (414)	18.4 (467)	6.2 (158)	13.8 (351)	3.79 (96)	3.6 (91)
4 (100)	4.5 (114)	11.9 (302)	12.6 (320)	16.5 (419)	21.0 (533)	5.5 (140)	16.8 (427)	4.54 (115)	4.3 (109)
6 ³ (150)	5.7 (145)	13.4 (340)	14.5 (368)	18.4 (467)	24.8 (630)	3.8 (97)	22.4 (569)	5.83 (148)	5.7 (145)
8 (200)	6.8 (174)	16.1 (409)	16.7 (424)	19.5 (495)	29.2 (742)	3.3 (84)	27.5 (699)	5.24 (133)	6.7 (170)

NOTES

1. Dimensions based on drain valves being open.
2. Dimensions do not provide installation clearance.
3. Also applicable to metric 165,1 mm size.

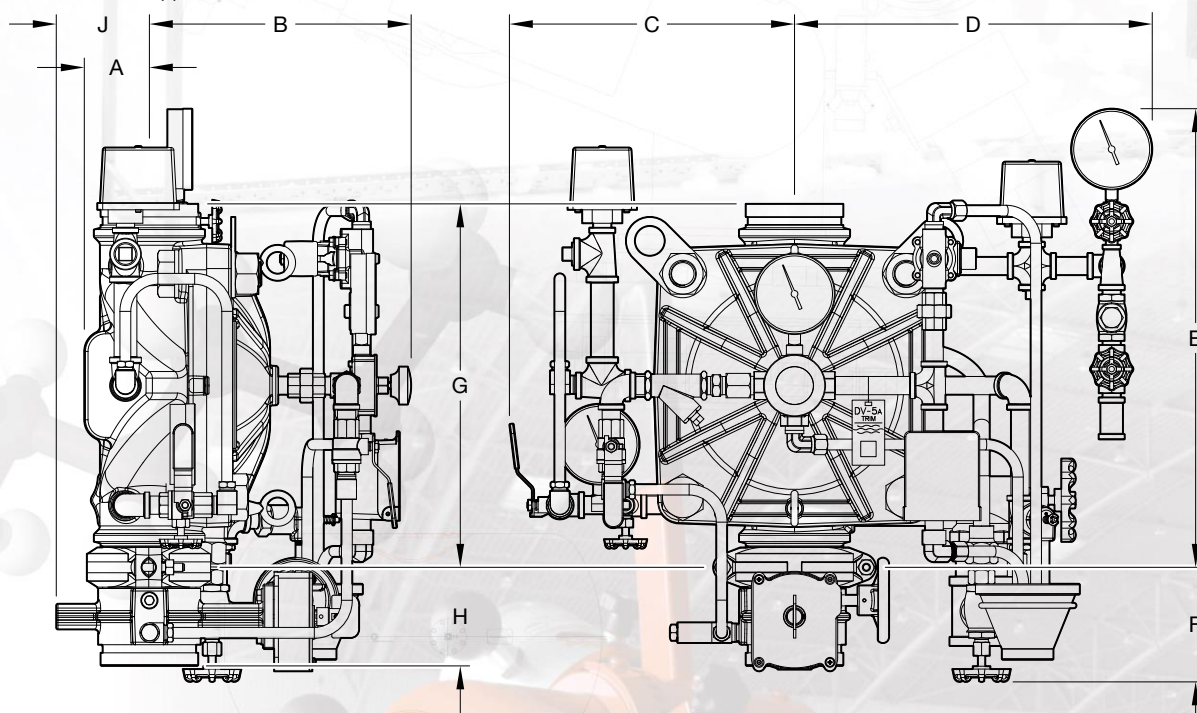

FIGURE 7
DV-5A VALVE
DOUBLE INTERLOCK PREACTION ELECTRIC/ELECTRIC ACTUATION TRIM
NOMINAL DIMENSIONS

Valve Setting Procedure

Perform Steps 1 through 20 when initially setting the TYCO DV-5A Valve, after an operational test of the fire protection system, or after system operation due to a fire. See Figure 8.

Step 1. Close the System Main Control Valve (B).

Step 2. Close the Diaphragm Supply Valve (P) and Air Supply Valve (S).

Step 3. Open the Main Drain Valve (D), System Drain Valve (E), and all auxiliary drains in the system. Close the auxiliary drain valves and the System Drain Valve (E) after water ceases to discharge. Leave the Main Drain Valve (D) open.

At this time make certain that the Pressure Gauge Valves and the Alarm Control Valve (H), as applicable, are open.

NOTICE

Do not open the Inspector's Test Connection and auxiliary drains if resetting after a system test; otherwise, system air pressure will be relieved unnecessarily.

Step 4. Depress the plunger of the Automatic Drain Valve (F) to verify that it is open.

Step 5. Clean the Diaphragm Supply Strainer (Q) by removing the clean-out plug and strainer basket. The Diaphragm Supply Strainer (Q) may be flushed out by momentarily opening the Diaphragm Supply Valve (P).

Step 6. Inspect for and clear all ice plugs where system piping has been exposed to freezing conditions and when there has been a flow of water into the system.

Step 7. Replace all damaged or operated sprinklers. Replacement sprinklers must be of the same type and temperature rating as those that operated.

NOTICE

In order to prevent the possibility of a subsequent operation of an overheated solder type sprinkler, any solder type sprinklers possibly exposed to a temperature greater than their maximum rated ambient must also be replaced.

Step 8. Service the air dryer, if applicable, in accordance with the manufacturer's instructions.

Step 9. De-energize the Solenoid Valve (V) via the Potter RCDS-1 Releasing Circuit Disable Switch, or equivalent.

Step 10. Operate (open) the Manual Control Station (M) and then open the Diaphragm Supply Valve (P). After unaerated water ceases to discharge from the Manual Control Station (M) drain tube, slowly close the operating lever by pushing it up. Do not close the hinged cover at this time.

Step 11. After allowing water to flow out of the Manual Reset Actuator (N) drain tube until aerated water ceases to discharge, reset the Manual Reset Actuator (N) by pressing the Reset Knob and hold until water stops flowing from its drain tube and the pressure builds and reaches approximately 15 psi (1,0 bar) on the Diaphragm Gauge (K). Pressure will then build up in the DV-5A Diaphragm Chamber.

Step 12. Inspect the actuation device drain connections. Any leaks must be corrected before proceeding to the next step. Electric/Electric Actuation drain connection to be inspected are from the Manual Control Station (M) and Solenoid Valve (V) shown in Figure 4.

Step 13. Verify the ability for the DV-5A Diaphragm to hold pressure as follows:

- With the diaphragm chamber pressurized per Step 11, temporarily close the Diaphragm Supply Valve (P), and then observe the Diaphragm Gauge (K) for a drop in pressure.
- If a drop in pressure is noted, the DV-5A Diaphragm is to be replaced and/or any leaks must be corrected before proceeding to the next step.
- If the Diaphragm Gauge (K) indicates no drop in pressure, re-open the Diaphragm Supply Valve (P) and proceed to the next step.

Step 14. Open the Air Supply Valve (S) and allow the system to automatically re-establish its nominal system air pressure. Observe the Automatic Drain Valve (F) for leaks. If there are leaks, determine/correct the cause of the leakage problem.

- Nominal system air pressure for Electric/Electric Actuation is typically 15 psi (1,0 bar).

Step 15. Open the System Shut-Off Valve (X), as will be the case when resetting a system after performing an operational test.

Step 16. Reset the electric detection system in accordance with the manufacturer's instructions. After setting the releasing panel, return the Potter RCDS-1 to "green light - releasing circuit system normal".

Step 17. Partially open the System Main Control Valve (B). Slowly close the Main Drain Valve (D) as soon as water discharges from the Main Drain Valve (D). Observe the Automatic Drain Valve (F) for leaks. If there are leaks, determine/correct the cause of the leakage problem before proceeding.

NOTICE

When the System Main Control Valve (B) is partially opened, the pressure on the DV-5A Diaphragm Chamber may increase. This increase in pressure is normal, and if the pressure is greater than 300 psi (20,7 bar), the pressure is to be relieved by partially and temporarily opening the Manual Control Station (M); however, do not allow the pressure as indicated on the Diaphragm Gauge (K) to drop below the supply pressure shown on the Water Supply Gauge (J), since this action may result in tripping of the DV-5A Valve.

Step 18. Close the hinged cover on the Manual Control Station (M) and insert a new break rod in the small hole through the top of the enclosing box.

Step 19. Fully open the System Main Control Valve (B).

Step 20. After setting a fire protection system, notify the proper authorities and advise those responsible for monitoring proprietary and/or central station alarms.

Item	Description	Item	Description	External Trim Connections	
A	DV-5A Valve	N	Manual Reset Actuator	C1	Diaphragm Supply Connection
B	System Main Control Valve	P	Diaphragm Supply Valve	C2	Water Motor Alarm Connection
C	Waterflow Pressure Switch	Q	Diaphragm Supply Strainer	C3	Air Supply Connection
D	Main Drain Valve	R	Inverted Flare Shut-Off Valve	C4	Waterflow Pressure Alarm Switch
E	System Drain Valve	S	Air Supply Valve		Connection
F	Automatic Drain Valve	T	Air Pressure Relief Valve	C5	Low Air Pressure Switch
G	Alarm Test Valve	U	Low Air Pressure Alarm Switch		Connection
H	Alarm Control Valve (Optional)	V	Solenoid Valve	C6	Main Drain Connection
J	Water Supply Gauge	W	Not Used	C7	Drip Funnel Drain Connection
K	Diaphragm Gauge	X	System Shut-Off Valve		(Shown in Figure 4)
L	System Gauge				
M	Manual Control Station				

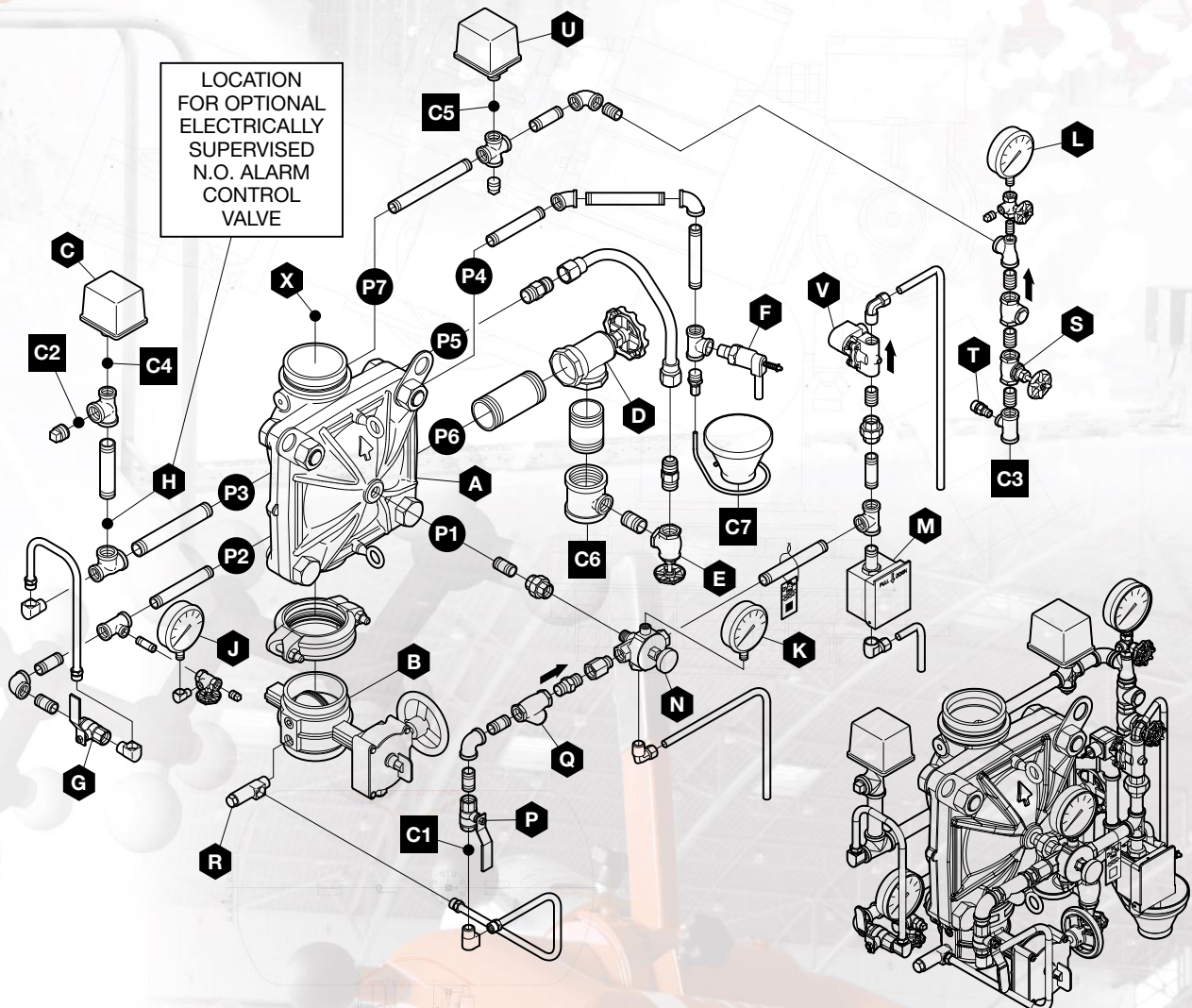

NOTES

- Port Connections P1 through P7 are described in Figure 2.

FIGURE 8
DV-5A VALVE - DOUBLE INTERLOCK PREACTION ELECTRIC/ELECTRIC ACTUATION
 (See Figure 6 for specific Bills of Materials)

Care and Maintenance

The following procedures and inspections must be performed as indicated, in addition to any specific requirements of the NFPA and any applicable standards recognized by the Approval agency. Any impairment must be immediately corrected. See Figure 8.

NOTICE

If the water supply needs to be shut off to the DV-5A valve and trim and cannot be shut off upstream of the system, close the System Main Control Valve (B), the Diaphragm Supply Valve (P), and the Water Supply Shut-Off Valve (R). This will allow any trim above the System Main Control Valve (B) to be taken apart for service if necessary.

The frequency at which the following procedures and inspections are to be performed are to be in accordance with the NFPA and any applicable specific requirements of the standards recognized by the Approval agency.

Before closing a fire protection system main control valve for maintenance work on the fire protection system that it controls, permission to shut down the affected fire protection systems must first be obtained from the proper authorities and all personnel who may be affected by this action must be notified.

The owner is responsible for the inspection, testing, and maintenance of their fire protection system and devices in compliance with this document, as well as with the NFPA and any applicable standards recognized by the Approval agency. Contact the installing contractor or product manufacturer with any questions.

Some procedures in this section result in the operation of the associated alarms. Notify the owner and the fire department, central station, or other signal station to which the alarms are connected before performing the tests. It is recommended that automatic sprinkler systems be inspected, tested, and maintained by a qualified Inspection Service in accordance with the NFPA and any applicable standards recognized by the Approval agency.

It is recommended that the System Inspection Procedure be performed at least semi-annually by a qualified Inspection Service. The Double Interlock Praction System Inspection Procedure may be followed in lieu of performing any of the operational

tests recommended in the Technical Data Sheets for the 24 VDC Solenoid Valve and Model MC-1 Manual Control Station.

It is recommended that the individuals responsible for the care and maintenance of the Double Interlock Praction System develop a working understanding of the system, in general, prior to performing inspection and/or maintenance procedures. These instructions, as well as individual instructions for the solenoid valve, dry pilot actuator, manual control station, switches, and pressure maintenance device should be reviewed.

The following procedures pertain to the automatic control valve portion of the Double Interlock Praction System. Refer to the manufacturer's instructions and NFPA 25 for care and maintenance procedures for all other devices (e.g., electric detection, main control and system shut-off valves, supervisory devices, sprinklers, etc.).

Before performing the System Inspection Procedure or Waterflow Alarm Test Procedure, which will result in operation of alarms, notify the proper authorities and all personnel who may be affected.

Drop in Water Supply Pressure Below Normal Range

NOTICE

If the water supply pressure is significantly reduced below the normally expected static pressure range (as could occur in the case of a water main break or repair), and there is a subsequent drop in the diaphragm chamber water pressure below its normal range (for example, due to a leak in a piping connection to or from the diaphragm chamber or, a leak in the diaphragm chamber check valve caused by dirt or debris in the check valve seal area), a deluge valve such as the DV-5A could inadvertently trip, if its water supply pressure is quickly restored.

A drop in the water supply pressure to below its normal range (as in the case of an interrupted water supply condition) constitutes an emergency impairment.

Should this condition occur, immediately close the System Main Control Valve (B) and use the following procedure to reset the system:

Step 1. Prior to the water supply pressure being restored to the closed System Main Control Valve (B), note the pressure indicated by the Diaphragm Gauge (K) and determine if the pressure is within the normally expected range.

Step 2. If the diaphragm chamber pressure is below the normal range, check for and correct any source of leakage from the diaphragm chamber prior to resetting the system.

Step 3. After the water supply pressure is restored to the System Main Control Valve (B), reset the DV-5A Valve in accordance with the Valve Setting Procedure section.

NOTICE

For fire protection systems subject to an emergency impairment caused by an interrupted water supply condition, it is recommended that consideration be given to installing a low water supply pressure switch with the appropriate alarm/indications to monitor the water supply pressure.

Waterflow Alarm Test Procedure

To test the waterflow alarm, open the Alarm Test Valve (G), which will allow a flow of water to the Waterflow Pressure Switch (C) and/or Water Motor Alarm. Upon satisfactory completion of the test, close the Alarm Test Valve (G).

To ensure drainage of the alarm line, depress the plunger on the Automatic Drain Valve (F).

Electric/Electric Actuation System Operation Procedure

Proper operation of the DV-5A Valve for both opening of the DV-5A Valve in a fire condition, or not opening the DV-5A Valve in a non-fire condition, must be verified as follows:

Step 1. Close the System Main Control Valve (B) and then open the Main Drain Valve (D).

Step 2. Manually operate Zone 1 of the Releasing Panel, and verify the following:

- The operation of the Releasing Panel and its associated alarms
- That there is no leakage from the Solenoid Valve (V)

NOTE: During this procedure, the Solenoid Valve (V) should remain closed and the DV-5A Deluge Valve Diaphragm Chamber should remain pressurized.

This procedure is used to verify that the DV-5A Deluge Valve will remain set if the electric detection system (Zone 1) operates but the sprinkler system (Zone 2) remains in its normally pressurized condition.

Step 3. Restore the electric fire detection system to a normal condition in accordance with the manufacturer's instructions.

Nominal Valve Sizes ANSI Inches (DN)	Torque lb-ft (N-m)	
	Nuts	Short Hex Bolts
1 1/2 (40)	44 (59,7)	35 (47,5)
2 (50)	44 (59,7)	35 (47,5)
3 (80)	125 (169,5)	125 (169,5)
4 (100)	150 (203,4)	150 (203,4)
6" (150)	150 (203,4)	150 (203,4)
8 (200)	188 (254,9)	188 (254,9)

NOTES
 1. Also applicable to metric 165,1 mm size.

TABLE B
DIAPHRAGM COVER BOLTS
MINIMUM TORQUE

Step 4. Open the Inspector's Test Connection to relieve system air pressure, and verify the following:

- That the Low Air Pressure Alarm Switch (U) and Zone 2 of the Releasing Panel, as well as its associated alarms, operate properly. The Low Air Pressure Alarm Switch (U) should operate at the previously established pressure (see Installation section, Step 9).
- That there is no leakage from the Solenoid Valve (V).

Step 5. Close the Inspector's Test Connection.

NOTE: During this procedure, the Solenoid Valve (V) should remain closed and the DV-5A Valve Diaphragm Chamber should remain pressurized.

This procedure is used to verify that the DV-5A Valve will remain set if the Low Air Pressure Alarm Switch (U) (Zone 2) operates due to loss of system air pressure and the electric detection system (Zone 1) remains in a normal condition.

Step 6. Restore the electric fire detection system to a normal condition in accordance with the manufacturer's instructions after the system air pressure has automatically been restored to normal.

Step 7. Close the System Shut-Off Valve (W) after the system air pressure has been restored to normal.

Step 8. Open the System Main Control Valve (B) one turn beyond the position at which water just begins to flow from the Main Drain Valve (D).

Step 9. Close the Main Drain Valve (D).

Step 10. Close the Air Supply Valve (S).

Step 11. Manually operate Zone 1 of the Releasing Panel, and then operate Zone 2 of the Releasing Panel by partially opening the System Drain Valve (E) to relieve air pressure at the Low Air Pressure Alarm Switch (U), and verify the following:

- That the DV-5A Valve operates as is indicated by a discharge of water from the System Drain Valve (E) and the Automatic Drain Valve (F). The Automatic Drain Valve (F) may or may not close depending on the flow past the partially open System Main Control Valve (B)
- That the Model MRA-1 Manual Reset Actuator (N) has operated as is indicated by water discharging into the Drip Funnel from the 1/2 in. drain tube connected to the Model MRA-1 Manual Reset Actuator (N)
- That the Waterflow Pressure Switch (C) and its associated alarms properly operate
- That the Water Motor Alarm, if applicable, properly operates

NOTE: This procedure simulates automatic system operation upon both electric detection and loss of system air pressure.

Internal Valve Inspection

Once every five years during the annual operational test procedure and prior to the DV-5A Valve being reset and with the DV-5A Valve de-pressurized, the interior of the DV-5A Valve must be cleaned and inspected for wear and damage. Damaged or worn parts must be replaced. (Replacement of the Diaphragm every ten years is recommended, or more frequently if inspections and/or wear and tear warrant more frequent replacement.)

NOTICE

The Diaphragm Cover may be removed between Steps 4 and 5 of the resetting instructions, since at that point the DV-5A Valve should be de-pressurized as evident by a zero gauge reading on the Diaphragm Gauge (K) and Water Supply Gauge (J), as well as no water discharging from the Automatic Drain Valve (F).

To perform internal valve inspection between Steps 4 and 5 of the Valve Setting Procedure remove the Diaphragm cover as follows:

Step 1. Close the Inverted Flare Shut-Off Valve (R).

Step 2. Remove the Copper Tube Fitting between the Diaphragm Supply Valve (P) and the Inverted Flare Shut-Off Valve (R).

Step 3. Loosen the union securing the Electric/Electric Actuation Trim and remove the Electric/Electric Actuation Trim.

Step 4. Loosen and remove the union between the Diaphragm Cover and the MRA-1 Manual Reset Actuator (N) and remove the MRA-1 Manual Reset Actuator (N) subassembly.

Step 5. Remove the Diaphragm Valve Cover hardware, then slowly remove the Diaphragm Cover and perform internal valve inspection. Clean the valve interior and replace parts as necessary.

After cleaning and inspecting valve interior, and replacing parts as necessary, reinstall the Diaphragm Cover by completing the following steps to assure the Diaphragm Cover Fasteners are uniformly and securely tightened.

Step 1. With reference to Figure 1, ensure that the Diaphragm is properly oriented and that the proper hardware arrangement is utilized when assembling the Diaphragm Covers. The hardware arrangements differ depending on the size of the DV-5A Valve.

Step 2. By first using the Long Hex Bolts, support of the Diaphragm Cover will be provided before installing the Short Hex Bolts. Align Diaphragm in proper orientation with Valve Body, and then align Diaphragm Cover in proper orientation with Valve Body. Hand-tighten all fasteners.

Step 3. Using crossdraw sequence to assure uniformity, wrench-tighten Long Hex Bolts and Short Hex Bolts to appropriate torque values. Repeat crossdraw sequence two to three times at incremental torque values until reaching the torque values found in Table B.

Step 4. Inspect to assure all Hex Bolts are securely tightened.

Step 5. Using the union, secure the MRA-1 Manual Reset Actuator (N) to the Diaphragm Cover.

Step 6. Using the union, secure the Electric/Electric Actuation Trim.

Step 7. Replace the Copper Tube Fitting between the Diaphragm Supply Valve (P) and the Inverted Flare Shut-Off Valve (R).

Step 8. Ensure that the unions and flare fittings are securely tightened.

Step 9. With the Diaphragm Supply Valve (P) closed, fully open the Inverted Flare Shut-Off Valve (R) stainless steel screw (approximately 1/2 in.) until resistance is met so as not to break the internal roll-pin. The internal roll-pin stops the removal of the Inverted Flare Shut-Off Valve (R) stainless steel screw.

Step 10. Proceed with Step 5 of the Valve Setting Procedures section in this data sheet.

NOTICE

If the water supply contains chemicals which tend to attack a polyester fabric-reinforced, EPDM rubber or the five year inspection indicates a build-up of debris within the DV-5A Valve that could affect its proper operation, then the frequency of the internal valve inspection procedure must be appropriately increased.

With reference to Figure 1, make certain that the Diaphragm is correctly oriented; otherwise, the DV-5A Valve cannot be properly set.

Under-tightening the Diaphragm Cover Bolts can result in internal and external leakage.

Use only TYCO replacement fasteners as specified in Figure 1.

Do not apply adhesives, lubricants, or other substances to the Diaphragm Valve Body.

Limited Warranty

For warranty terms and conditions, visit www.tyco-fire.com.

Ordering Procedure

Order the TYCO DV-5A Automatic Water Control Valves as follows:

Pre-Assembled Valves with Trim

DV-5A Valves with Galvanized Trim and Butterfly Valve

Specify: Size (specify), DV-5A Automatic Water Control Valve, G x G connections with assembled galvanized Americas Double Interlock Preaction with Electric/Electric Actuation Trim, complete with assembled Model BFV-300 Butterfly Valve, P/N (specify):

1 1/2 in. (DN40)	551011515
2 in. (DN50)	551011520
3 in. (DN80)	551011530
4 in. (DN100)	551011540
6 in. (DN150)	551011560
8 in. (DN200)	551011580

Notes:

Americas pressure switches, P/N 52-287-1-124 Solenoid Valve, and psi/kPa water pressure gauges are provided.

This arrangement is available for EMEA and APAC upon request. Contact your local distributor.

AMERICAS

DV-5A Valves with Galvanized Trim

Specify: Size (specify), DV-5A Automatic Water Control Valve, (specify) end connection with assembled galvanized Americas, Double Interlock Preaction Electric/Electric Actuation Trim, P/N (specify):

Grooved x Grooved

1 1/2 in. (DN40)	550011515
2 in. (DN50)	550011520
3 in. (DN80)	550011530
4 in. (DN100)	550011540
6 in. (DN150)	550011560
8 in. (DN200)	550011580

Flange x Flange ANSI

3 in. (DN80)	550021530
4 in. (DN100)	550021540
6 in. (DN150)	550021560
8 in. (DN200)	550021580

Flange x Grooved ANSI

3 in. (DN80)	550031530
4 in. (DN100)	550031540
6 in. (DN150)	550031560
8 in. (DN200)	550031580

T x T NPT

1 1/2 in. (DN40)	550061515
2 in. (DN50)	550061520

Note: Pressure switches, P/N 52-287-1-124 solenoid valve, and psi/kPa water pressure gauges are provided.

Separate DV-5A Valves without Trim
See Table A for flange drilling specifications.

Specify: Size (specify), DV-5A Automatic Water Control Valve, (specify) end connection, P/N (specify):

Groove x Groove

1 1/2 in. (DN40)	530010015
2 in. (DN50)	530010020
3 in. (DN80)	530010030
4 in. (DN100)	530010040
6 in. (DN150)	530010060
8 in. (DN200)	530010080

Flange x Flange ANSI

3 in. (DN80)	530020030
4 in. (DN100)	530020040
6 in. (DN150)	530020060
8 in. (DN200)	530020080

Flange x Groove ANSI

3 in. (DN80)	530030030
4 in. (DN100)	530030040
6 in. (DN150)	530030060
8 in. (DN200)	530030080

T x T NPT

1 1/2 in. (DN40)	530060015
2 in. (DN50)	530060020

Notes:

Valves are typically provided with flange drilling per ANSI B16.1 (Class 125) or ISO (7005-2 PN16).

Upon request, valves can be provided with flange drilling per JIS B 2210 or AS 2129. In which case part numbers are not assigned.

DV-5A Valve Trim

Specify: Size (specify), finish (specify), Electric/Electric Actuation Trim for DV-5A Automatic Water Control Valves used in Double Interlock Preaction Fire Protection System, P/N (specify):

Galvanized

1 1/2 in. (DN40)	540001520
2 in. (DN50)	540001520
3 in. (DN80)	540001530
4 in. (DN100)	540001540
6 in. (DN150)	540001560
8 in. (DN200)	540001580

Note: Pressure switches and/or solenoid valves for electric actuation are separately ordered.

EMEA

DV-5A Valves with Galvanized Trim

Specify: Size (specify), DV-5A Automatic Water Control Valve, (specify) end connection with assembled galvanized EMEA, Double Interlock Preaction Electric/Electric Actuation Trim, P/N (specify):

Grooved x Grooved

1 1/2 in. (DN40)	550111515
2 in. (DN50)	550111520
3 in. (DN80)	550111530
4 in. (DN100)	550111540
6 in. (DN150)	550111560
165,1 mm	550111566
8 in. (DN200)	550111580

Flange x Flange ANSI

3 in. (DN80)	550121530
4 in. (DN100)	550121540
6 in. (DN150)	550121560
8 in. (DN200)	550121580

Flange x Grooved ANSI

3 in. (DN80)	550131530
4 in. (DN100)	550131540
6 in. (DN150)	550131560
8 in. (DN200)	550131580

Flange x Flange ISO

3 in. (DN80)	550141530
4 in. (DN100)	550141540
6 in. (DN150)	550141560
8 in. (DN200)	550141580

Flange x Grooved ISO

3 in. (DN80)	550151530
4 in. (DN100)	550151540
6 in. (DN150)	550151560
8 in. (DN200)	550151580

T x T ISO

1 1/2 in. (DN40)	550171515
2 in. (DN50)	550171520

Note: Pressure switches, P/N 52-287-1-124 solenoid valve, bar/psi water pressure gauges, and NPT to ISO threaded trim adaptors for external connections are provided.

Separate DV-5A Valves without Trim
See Table A for flange drilling specifications.

Specify: Size (specify), DV-5A Automatic Water Control Valve, (specify) end connection, P/N (specify):

Groove x Groove

1 1/2 in. (DN40)	530010015
2 in. (DN50)	530010020
3 in. (DN80)	530010030
4 in. (DN100)	530010040
6 in. (DN150)	530010060
165,1 mm	530010066
8 in. (DN200)	530010080

Flange x Flange ANSI

3 in. (DN80)	530020030
4 in. (DN100)	530020040
6 in. (DN150)	530020060
8 in. (DN200)	530020080

Flange x Groove ANSI

3 in. (DN80)	530030030
4 in. (DN100)	530030040
6 in. (DN150)	530030060
8 in. (DN200)	530030080

T x T NPT

1 1/2 in. (DN40)	530060015
2 in. (DN50)	530060020

Flange x Flange ISO

3 in. (DN80)	530040030
4 in. (DN100)	530040040
6 in. (DN150)	530040060
8 in. (DN200)	530040080

Flange x Groove ISO

3 in. (DN80)	530050030
4 in. (DN100)	530050040
6 in. (DN150)	530050060
8 in. (DN200)	530050080

T x T ISO

1 1/2 in. (DN40)	530070015
2 in. (DN50)	530070020

Notes:

Valves are typically provided with flange drilling per ANSI B16.1 (Class 125) or ISO (7005-2 PN16).

Upon request, valves can be provided with flange drilling per JIS B 2210 or AS 2129. In which case part numbers are not assigned.

DV-5A Valve Trim

Specify: Size (specify), finish (specify), Double Interlock Preaction Electric/ Electric Actuation Trim for DV-5A Automatic Water Control Valves used in Deluge Fire Protection System, P/N (specify):

Galvanized

1 1/2 in. (DN40)	540101520
2 in. (DN50)	540101520
3 in. (DN80)	540101530
4 in. (DN100)	540101540
6 in. (DN150)	540101560
8 in. (DN200)	540101580

Note: Pressure switches, solenoid valves for electric actuation, water pressure gauges, and BFV-300 Butterfly Valve are separately ordered. NPT to ISO threaded adaptors are provided for External Trim Connections (drains, pressure switches, water motor alarms, etc.).

APAC
DV-5A Valves with Galvanized Trim

Specify: Size (specify), DV-5A Automatic Water Control Valve, (specify) end connection with assembled galvanized APAC, Double Interlock Preaction Electric/Electric Actuation Trim, P/N (specify):

Grooved x Grooved

1 1/2 in. (DN40)	550011515
2 in. (DN50)	550011520
3 in. (DN80)	550011530
4 in. (DN100)	550011540
6 in. (DN150)	550011560
165.1 mm	550011566
8 in. (DN200)	550011580

Flange x Flange ANSI

3 in. (DN80)	550021530
4 in. (DN100)	550021540
6 in. (DN150)	550021560
8 in. (DN200)	550021580

Flange x Grooved ANSI

3 in. (DN80)	550031530
4 in. (DN100)	550031540
6 in. (DN150)	550031560
8 in. (DN200)	550031580

T x T NPT

1 1/2 in. (DN40)	550061515
2 in. (DN50)	550061520

Flange x Flange ISO

3 in. (DN80)	550041530
4 in. (DN100)	550041540
6 in. (DN150)	550041560
8 in. (DN200)	550041580

Flange x Grooved ISO

3 in. (DN80)	550051530
4 in. (DN100)	550051540
6 in. (DN150)	550051560
8 in. (DN200)	550051580

Note: Pressure switches, P/N 52-287-1-124 solenoid valve, and psi/kPa water pressure gauges are provided.

Separate DV-5A Valves without Trim
 See Table A for flange drilling specifications.

Specify: Size (specify), DV-5A Automatic Water Control Valve, (specify) end connection, P/N (specify):

Groove x Groove

1 1/2 in. (DN40)	530010015
2 in. (DN50)	530010020
3 in. (DN80)	530010030
4 in. (DN100)	530010040
6 in. (DN150)	530010060
165.1 mm	530010066
8 in. (DN200)	530010080

Flange x Flange ANSI

3 in. (DN80)	530020030
4 in. (DN100)	530020040
6 in. (DN150)	530020060
8 in. (DN200)	530020080

Flange x Groove ANSI

3 in. (DN80)	530030030
4 in. (DN100)	530030040
6 in. (DN150)	530030060
8 in. (DN200)	530020080

T x T NPT

1 1/2 in. (DN40)	530060015
2 in. (DN50)	530060020

Flange x Flange ISO

3 in. (DN80)	530040030
4 in. (DN100)	530040040
6 in. (DN150)	530040060
8 in. (DN200)	530040080

Flange x Groove ISO

3 in. (DN80)	530050030
4 in. (DN100)	530050040
6 in. (DN150)	530050060
8 in. (DN200)	530050080

T x T ISO

1 1/2 in. (DN40)	530070015
2 in. (DN50)	530070020

Notes:

Valves are typically provided with flange drilling per ANSI B16.1 (Class 125) or ISO (7005-2 PN16).

Upon request, valves can be provided with flange drilling per JIS B 2210 or AS 2129. In which case part numbers are not assigned.

DV-5A Valve Trim

Specify: Size (specify), finish (specify), Double Interlock Preaction Electric/ Electric Actuation Trim for DV-5A Automatic Water Control Valves used in Deluge Fire Protection System, P/N (specify):

Galvanized

1 1/2 in. (DN40)	540001520
2 in. (DN50)	540001520
3 in. (DN80)	540001530
4 in. (DN100)	540001540
6 in. (DN150)	540001560
8 in. (DN200)	540001580

DV-5A Valve Trim Accessories
(for separately ordered valve trim)

Specify: (Specify Accessory Description), P/N (specify):

Model QRS Quick Release Switch Q1	Refer to Technical Data Sheet TFP1100
Waterflow Pressure Alarm Switch Double Contacts (Americas)	25710
Waterflow Pressure Alarm Switch Double Contacts (APAC)	25710 or 100102
Waterflow Pressure Alarm Switch (EMEA)	0260 or 100101
Model WMA-1 Water Motor Alarm (America/APAC)	526301001P
Model WMA-1 Water Motor Alarm (EMEA)	526301021R
Model AMD-1 Air Maintenance Device	523242002
Model AMD-3 Nitrogen Maintenance Device	523282001
Model MC-1 Manual Control Stations	522892001
Water Gauges with bar/psi	025500013
600 psi Water Gauge psi/kPa (service pressure over 300 psi)	923431004
Solenoid Valve for Releasing Service	Refer to Technical Data Sheet TFP2180

DV-5A Valve Replacement Parts

Specify: (Description) for use with (specify size) DV-5A Automatic Water Control Valve, P/N (See Figure 1)

DV-5A Valve Trim Replacement Parts

Specify: (Description) for use with DV-5A Valve Trim, P/N (See Figure 6)

1467 Elmwood Avenue, Cranston, RI 02910 | Telephone +1-401-781-8220

© 2023 Johnson Controls. All rights reserved. All specifications and other information shown were current as of document revision date and are subject to change without notice.

NATIONAL FIRE PROTECTION ASSOCIATION and NFPA are registered trademarks of National Fire Protection Association;
TEFLON is a trademark of The Chemours Company FC, LLC

**Johnson
Controls**

NIP: 531-163-86-70
REGON: 146196990

tyco

Worldwide
Contacts | www.tyco-fire.com

Summary Instructions DV-5A Automatic Water Control Valve Double Interlock Electric/Electric Preaction Fire Protection System

NOTICE

The procedures provided are summary instructions of the complete procedures appearing in Technical Data Sheet TFP1466. If problems occur, consult full document.

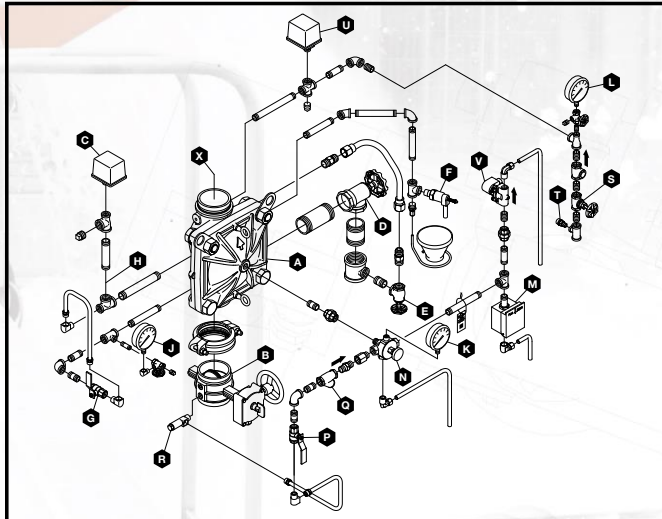

Item	Description
A	DV-5A Valve
B	System Main Control Valve
C	Waterflow Pressure Switch
D	Main Drain Valve
E	System Drain Valve
F	Automatic Drain Valve
G	Alarm Test Valve
H	Alarm Control Valve (Optional)
J	Water Supply Gauge
K	Diaphragm Gauge
L	System Gauge

Item	Description
M	Manual Control Station
N	Manual Reset Actuator
P	Diaphragm Supply Valve
Q	Diaphragm Supply Strainer
R	Inverted Flare Shut-Off Valve
S	Air Supply Valve
T	Air Pressure Relief Valve
U	Low Air Pressure Alarm Switch
V	Solenoid Valve
W	Not Used
X	System Shut-Off Valve

Valve Setting Procedure

1. Close System Main Control Valve (B), Diaphragm Supply Valve (P) and, Air Supply Valve (S).
2. Open Main Drain Valve (D), System Drain Valve (E), and all auxiliary drains in the system. Close auxiliary drain valves and System Drain Valve (E) after water stops discharging. Leave Main Drain Valve (D) open.
3. Depress plunger of Automatic Drain Valve (F) to verify it is open.
4. Clean Diaphragm Supply Strainer (Q). Flush strainer by opening the Diaphragm Supply Valve (P).
5. Inspect for and clear all ice plugs where system piping has been exposed to freezing conditions.
6. Replace operated sprinklers.
7. Service air dryer, if applicable, in accordance with the manufacturer's instructions.
8. De-energize Solenoid Valve (V) via Potter RCDS-1 Releasing Circuit Disable Switch, or equivalent.
9. Open Manual Control Station (M), then open Diaphragm Supply Valve (P). After aerated water stops discharging, slowly close operating lever. Do not close hinged cover at this time.
10. After aerated water stops discharging, reset Manual Reset Actuator (N) until water stops flowing from the drain tube and the pressure builds and reaches approximately 15 psi (1,0 bar) on Diaphragm Gauge (K).
11. Inspect Electric/Electric actuation drain connection from Manual Control Station (M) and Solenoid Valve (V). Correct any leaks before proceeding.
12. With diaphragm chamber pressurized, temporarily close Diaphragm Supply Valve (P), and observe Diaphragm Gauge (K) for a drop in pressure. If a pressure drop is noted, correct any leaks before proceeding. If Diaphragm Gauge (K) indicates no drop in pressure, re-open Diaphragm Supply Valve (P) and proceed.
13. Open Air Supply Valve (S) and allow system to automatically re-establish nominal system air pressure of 15 psi (1,0 bar). Observe Automatic Drain Valve (F) for leaks. If there are leaks, correct leaks before proceeding.
14. Open System Shut-Off Valve (X), as will be the case when resetting a system after performing an operational test.
15. Proceed to reset electric detection system in accordance with the manufacturer's instructions. After setting releasing panel, return Potter RCDS-1 to "green light - releasing circuit system normal".
16. Partially open System Main Control Valve (B). Slowly close Main Drain Valve (D) as water discharges from Main Drain Valve (D). Observe Automatic Drain Valve (F) for leaks. If there are leaks, correct the leakage problem.
17. Close hinged cover on Manual Control Station (M) and insert a new break rod in small hole through top of enclosing box.
18. Fully open System Main Control Valve (B).
19. After setting fire protection system, notify proper authorities and advise those responsible for monitoring proprietary and/or central station alarms.

Drop in Water Supply Pressure Below Normal Range

1. Note water supply pressure by the Diaphragm Gauge (K) and determine if the pressure is within normally expected range.
2. If below normal range, correct any leakage from diaphragm chamber prior to resetting the system.
3. When water supply pressure is restored, reset DV-5A Valve in accordance with the Valve Setting Procedure.

Waterflow Alarm Test Procedure

1. Open Alarm Test Valve (G), allowing water to flow to Waterflow Pressure Switch (C) and/or Water Motor Alarm. Close the Alarm Test Valve (G) when test is completed.
2. Depress plunger on Automatic Drain Valve (F) to drain alarm line.

Scan the QR code or enter the URL in a web browser to access the most up-to-date electronic version of this document. Data rates may apply.



docs.jci.com/tycofire/TFP1466

TFP1466 APPENDIX A
JUNE 2023

Electric/Electric Actuation System Operation Procedure

1. Close System Main Control Valve (B) and open Main Drain Valve (D).
2. Manually operate Zone 1 of Releasing Panel, and verify operation of Releasing Panel and associated alarms, and there is no leakage from Solenoid Valve (V)
3. Restore electric fire detection system to normal condition in accordance with manufacturer's instructions.
4. Open Inspector's Test Connection to relieve system air pressure, and verify Low Air Pressure Alarm Switch (U) and Zone 2 of Releasing Panel, as well as associated alarms, operate properly. Low Air Pressure Alarm Switch (U) should operate at previously established pressure. Verify no leakage from Solenoid Valve (V)
5. Close Inspector's Test Connection.
6. Restore electric fire detection system to a normal condition in accordance with manufacturer's instructions after system air pressure has automatically been restored to normal.
7. Close System Shut-Off Valve (W) after system air pressure has been restored to normal.
8. Open System Main Control Valve (B) one turn beyond which water begins to flow from Main Drain Valve (D).
9. Close Main Drain Valve (D) and Air Supply Control Valve (S).
10. Manually operate Zone 1 of Releasing Panel, then operate Zone 2 of Releasing Panel by partially opening System Drain Valve (E) to relieve air pressure at Low Air Pressure Alarm Switch (U). Verify DV-5a Valve operates as is indicated by discharging water from System Drain Valve (E) and Automatic Drain Valve (F). Automatic Drain Valve (F) may or may not close depending on flow past partially open System Main Control Valve (B)
11. Verify Model MRA-1 Manual Reset Actuator (N) has operated indicated by water discharging into Drip Funnel from drain tube connected to Model MRA-1 Manual Reset Actuator (N), that Waterflow Pressure Switch (C) and its associated alarms properly operate, and Water Motor Alarm, if applicable, properly operates.

Internal Valve Inspection

1. Ensure that Steps 1 to 4 of the Valve Setting Procedure are completed prior to proceeding with the Internal Valve Inspection.
2. Ensure Diaphragm Supply Valve (P) is closed. If provided as part of the valve trim, close Inverted Flare Shut-Off Valve (R).
3. Remove the Supply Line between the Diaphragm Supply Valve (P) and the System Main Control Valve (B). If provided as part of the valve trim, remove the Supply Line between the Diaphragm Supply Valve (P) and Inverted Flare Shut-Off Valve (R).
4. Loosen union securing Actuation Trim and remove Actuation Trim.
5. Remove union between Diaphragm Cover and MRA-1 Manual Reset Actuator (N). Remove MRA-1 Manual Reset Actuator (N) subassembly.
6. Remove Diaphragm Valve Cover hardware, slowly remove Diaphragm Cover and perform internal valve inspection. Clean valve interior and replace parts as necessary.
7. Ensure Diaphragm is properly oriented and proper hardware arrangement is utilized.
8. Insert Long Hex Bolts. Align Diaphragm with Valve Body, and then align Diaphragm Cover with Valve Body. Insert Short Hex Bolts. Hand-tighten all fasteners.
9. Using crossdraw sequence, wrench-tighten Long Hex Bolts and Short Hex Bolts. Repeat crossdraw sequence two to three times at incremental torque values.
10. Inspect to assure all Hex Bolts are securely tightened.
11. Using the union, secure the MRA-1 Manual Reset Actuator (N) to the Diaphragm Cover.
12. Using union, secure Actuation Trim.
13. Replace the Supply Line between the Diaphragm Supply Valve and the System Main Control Valve (B). If provided as part of the valve trim, replace Supply Line between Diaphragm Supply Valve (P) and Inverted Flare Shut-Off Valve (R).
14. Ensure unions and flare fittings are securely tightened.
15. If provided with the valve trim, and with Diaphragm Supply Valve (P) closed, fully open Inverted Flare Shut-Off Valve (R) stainless steel screw (approximately 1/2 in.) until resistance is met.
16. Proceed with Step 5 of the Valve Setting Procedures.

1467 Elmwood Avenue, Cranston, RI 02910 | Telephone +1-401-781-8220

© 2023 Johnson Controls. All rights reserved. All specifications and other information shown were current as of document revision date and are subject to change without notice.

Johnson
Controls



NIP: 531-163-86-70
REGON: 146196990



 Worldwide
 Contacts

www.tyco-fire.com

TFP1466 Change History Appendix

ISSUE DATE	NOTES
08-23	Pages 16 and 17, Ordering Procedure, removed all instances of Black trim; Page 17, Valve Trim Accessories sub-section, updated Waterflow Pressure Alarm Switch nomenclature, PS10-2 (America) part number to 25710, previously 25720, removed PS10-2 and PS10-1 model numbers from APAC and EMEA descriptions, expanded part numbers for EMEA to include 0260 OR 100101, formerly just 0260.
05-23	Page 11, Figure 6 (2 of 2), Item A2, Waterflow Pressure Alarm Switch, Single Contacts (EMEA), added alternate P/N 100101, Item A3, Low Air Pressure Alarm Switch, Single Contacts (EMEA), added alternate P/N 100401.
09-22	Technical Data Sheet TFP1466 describing DV-5A Automatic Water Control Valve with Preaction Fire Protection System Double-Interlock Electric/Electric Actuation Trim has been revised: Page 1, updated QR code and URL; Page 7, removed not applicable Graph B Air Pressure Requirements; Page 11, Figure 6 (2 of 2), Items A2 and A3, updated Waterflow and Low Pressure Alarm Switch part numbers and regional applicability; Page 12, Figure 7, updated dimensions; Page 18, changed corporate address and telephone number to 1467 Elmwood Avenue, Cranston, RI 02910 Telephone +1-401-781-8220, formerly 1400 Pennbrook Parkway, Lansdale, PA 19446 Telephone +1-215-362-0700; Incorporated Appendix A into document, including print instructions.
06-22	Page 16, Table B, updated Diaphragm Chamber Cover Bolt minimum torque specifications for all valve sizes. Separate Appendix A also updated to reflect TFP1466 issue date.
04-22	Page 1, added QR code and URL to allow convenient access to electronic version from printed document; Page 7, Releasing Circuit sub-section, changed to recommendation that circuit be equipped with Potter RCDS-1 Releasing Circuit Switch, or equivalented, formerly stated as requirement. Separate Appendix A also updated to reflect TFP1466 issue date.
08-21	Corrected Ordering Procedure Trim Accessories sub-section to change Solenoid Valve technical data sheet reference to TFP2180, formerly shown as TFP2108. Separate Appendix A also updated to reflect TFP1466 issue date.
06-21	Added metric 165,1 mm size. Separate Appendix A also updated to reflect TFP1466 issue date.
12-20	Corrected Valve Setting Procedure, Supervisory Air Supply Valve item reference letter changed from R to S to correspond with Figure 8. Separate Appendix A is also updated to reflect TFP1466 issue date.
05-20	New Technical Data Sheet TFP1466 describes DV-5A Automatic Water Control Valve with Preaction Fire Protection System Double-Interlock Electric/Electric Actuation Trim, formerly described in now-obsolete technical data sheet TFP1450. Separate Appendix A operation and setting procedure poster issued in conjunction with TFP1466.

1467 Elmwood Avenue, Cranston, RI 02910 | Telephone +1-401-781-8220

© 2023 Johnson Controls. All rights reserved. All specifications and other information shown were current as of document revision date and are subject to change without notice.

 Johnson
 Controls 

 NIP: 531-163-86-70
 REGON: 146196990

Foamax[®]
 Fire fighting systems & equipment

 SABO
 FOAM



InfraTec



